

# nano

PURIFICATION SOLUTIONS



## HEATLESS DESICCANT AIR DRYER

---

SERIES 3 AIR DRYER USER GUIDE

<b>Contents</b>		<b>Page</b>
<b>1.</b>	<b>General information</b>	<b>3</b>
	1.1. Document introduction	3
	1.2. North America Support Details   Manufacturers details	3
	1.3. Warranty Guidelines	4
	1.4. Packaging	4
<b>2.</b>	<b>General safety</b>	<b>5</b>
	2.1. Intended Use	5
	2.2. Personnel	5
	2.3. Safe Handling	5
<b>3.</b>	<b>Technical Description</b>	<b>6</b>
<b>4.</b>	<b>Technical Specification</b>	<b>6</b>
<b>5.</b>	<b>Product Contents</b>	<b>7</b>
<b>6.</b>	<b>Unpacking Guide</b>	<b>8</b>
<b>7.</b>	<b>Product Dimensions</b>	<b>9</b>
<b>8.</b>	<b>Equipment Overview</b>	<b>10</b>
<b>9.</b>	<b>System Layout</b>	<b>11</b>
<b>10.</b>	<b>Mechanical Installation</b>	<b>12</b>
<b>11.</b>	<b>Electrical Installation</b>	<b>13</b>
<b>12.</b>	<b>Dryer Operation</b>	<b>14</b>
	12.1. Dryer Remote Control	14
	12.2. Dryer Start up	15
	12.3. Monitoring Dryer Performance	16
	12.4. Shutdown Procedure	16
<b>13.</b>	<b>Maintenance</b>	<b>17</b>
	13.1. Maintenance guidelines	17
	13.2. Cleaning	17
	13.3. Daily checks	17
<b>14.</b>	<b>Servicing</b>	<b>17</b>
	14.1. Guidelines	18
	14.2. Procedures	19
	14.3. Additional Kits	19
<b>15.</b>	<b>Troubleshooting</b>	<b>20</b>

# 1. General Information

This manual is copyrighted, all rights reserved. It may not, in whole or in part, be copied, photocopied, reproduced, translated, or reduced to any electronic medium or machine readable form without prior consent in writing from nano purification solutions. It may not be distributed through the internet or computer bulletin board systems without prior consent from nano purification solutions.

**©2014 nano purification solutions.**  
**Product: Series 3 Desiccant Air Dryer**  
**Document number: 17-110-0140**  
**Issue: 003**

## 1.1 Document Introduction

This manual provides factory prescribed installation and maintenance procedures for a nano purification solutions compressed air dryer. The procedures illustrated in this document are only to be performed by authorized personnel. For further information regarding the procedures outlined in this document contact nano purification solutions before proceeding.

Read this document carefully before attempting to install or operate the dryer. This document should be permanently available at the dryer installation site and be kept in an easily accessible place alongside the dryer.

## 1.2 Support

For parts and technical support please contact:

### nano-purification solutions

11330 Vanstory Drive  
 Huntersville, NC 28078  
 USA

Telephone: (704) 897-2182  
 Fax: (704) 897-2183  
 Internet: [www.n-psi.com](http://www.n-psi.com)  
 E-mail: [support@n-psi.com](mailto:support@n-psi.com)



**Manufactured in the UK**  
 in an ISO 9001 certified facility

### Annotations:



**CAUTIONS:** indicate any situation or operation that may result in potential damage to the product, injury to the user, or render the product unsafe.



**NOTES:** highlight important sections of information where particular care and attention should be paid.

### 1.3 Warranty Guidelines

All products are supplied with a 5 year manufacturer's warranty from the date of purchase, when purchased with an ES (Energy Saving) system and installed and maintained in accordance with the manufacturers guidelines. Only genuine service parts should be used and no modifications made. For further information please contact nano purification solutions.

### 1.4 Packaging

All products are securely packaged in a specifically designed wooden packing box. The dryer will be held in a horizontal position by wooden struts; using straps to secure the product to the box base. The box top cover can be removed by removing the 4 fixing screws and lifting off in one piece.

#### Damage to Packaging

- Check immediately to establish whether damage has occurred to the external packaging and if the damage extends to the product inside.
- If there is damage to a product, contact the relevant supplier immediately.



In no circumstances must a damaged product be used in operation. Using damaged products can lead to irreparable functional faults or cause serious physical harm.



The support packing box permits longitudinal stacking; however the central section of the packing box should not be considered load bearing.

## 2. General safety



**For your own safety, when carrying out work on this product, all relevant national safety regulations must be complied with relating to pressurized and electrical systems.**

### 2.1. Intended use of the Product

The dryer is exclusively intended for the treatment of compressed air, which is free from bulk water, oil and solid matter constituents.

The product should be located within a building and protected. The dryer must be operated only in accordance with the data on the rating plate. Any operations that do not comply with those stated on the product rating plate will render the warranty void.



**This product is only designed to operate at pressures of between 58 - 145 psig (4 - 10 barg). It is not suitable for pressures in excess of 145 psig (10 barg).**

No modifications must be made to the product. Any modifications may reduce the operational safety of the product and invalidate the manufacturer's warranty. This could potentially result in damage to the product and serious personal injury.

### 2.2. Personnel

Only authorized, competent and trained personnel are permitted to work on this product. This user guide is intended solely for such personnel and is to be used only as a reference; it should not be used to replace conventional training.

### 2.3. Safe Handling

Please ensure the relevant safe engineering practices and handling procedures are employed when handling, installing and operating this product. Ensure that the equipment is depressurized and electrically isolated prior to carrying out any of the scheduled maintenance instructions specified within this user guide.



*A suitable lifting aid must be used to minimize the risk of physical injury or damage to the product.*



**In no circumstances must a damaged product be used in operation. Using damaged products can lead to irreparable functional faults or cause serious physical harm.**

### 3. Technical Description

The n-psi dryer uses the pressure swing adsorption principle of drying compressed air, utilizing two identical columns each containing a hygroscopic desiccant bed.

- Inlet filtration removes water, oil aerosols and particles (Inlet filtration supplied separately).
- Wet air enters the dryer through the inlet valve and is directed into one of the columns.
- Each column contains a densely filled desiccant bed.
- Air then passes through the desiccant bed where any remaining moisture is adsorbed.
- Simultaneously, a small amount of dry filtered air is counter flowed down through the other desiccant bed and exhausted to atmosphere, removing the moisture and regenerating the desiccant bed.
- The dryer controller periodically switches columns after top end repressurization; ensuring a continuous supply of dry air at constant pressure. The dryer can also be controlled using a Zero Volt signal from the compressor. This energy saving mode senses when the compressor is switched off and stops the dryer operation until the compressor restarts.
- The dry air passes out through the final particulate filter (<1micron/ISO8573.1 Class 2).

### 4. Technical Specification

Specification	
<b>ISO 8573 - 2:2001 Quality Classes</b>	Class 2: Water: -40°F (-40°C) PDP / Class 2: Dirt: 1µm Optional Class 1 (-100°F) and Class 3 (0°F)
<b>Minimum working pressure</b>	58 psig (4 bar)
<b>Maximum working pressure</b>	145 psig (10 bar) - higher pressures available upon request
<b>Power Supply</b>	100 - 240v AC / 50 - 60Hz
<b>Minimum inlet temperature</b>	34.7°F (1.5°C)
<b>Maximum inlet temperature</b>	122°F (50°C)
<b>Ambient Temperature</b>	34-122°F (1-50°C)
<b>IP Rating</b>	IP54 / NEMA 3
<b>Power</b>	38W

- Flow rate based on air inlet pressure of 100 psig (7.0 barg) and temperature of 95°F (35°C).
- For dryer performance at other inlet conditions or -100°F (-70°C) dewpoint requirements, contact support@n-psi.com.
- All dryers should be preceded by a coalescing filter regardless of oil or oil free applications, a nano M01 grade coalescing filter must be installed on the inlet to the dryer.

## 5. Product Contents

1. **Series 3 Compressed Air Dryer**
2. **Documentation**
  - 1 x User Guide
  - 1 x Declaration of Conformity
3. **Packaging**
  - 1 x Dryer support base and box cover

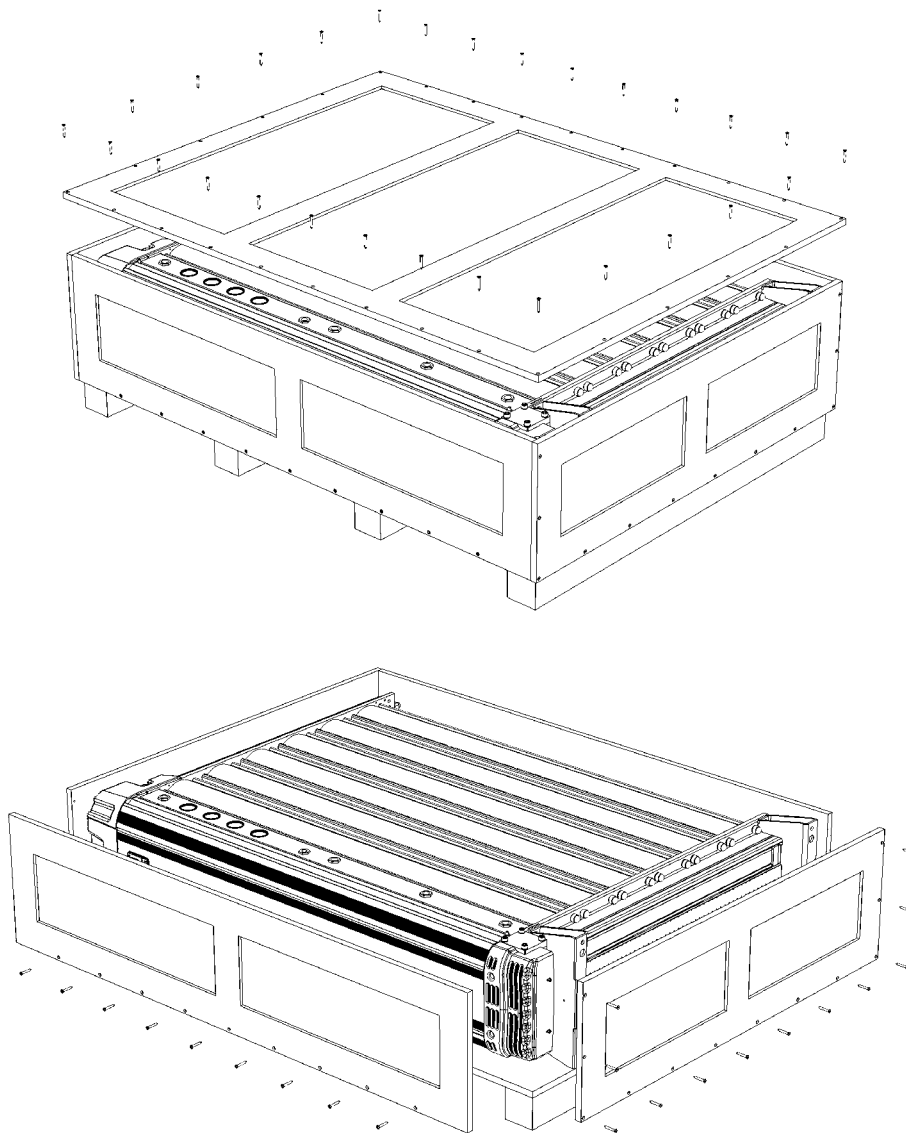

Figure 1: Contents Layout

## 6. Unpacking Guide

The dryer is supplied in a wooden crate. It is recommended that the crate be moved into position using a forklift truck or pallet truck. Remove the dryer from the wooden crate using an overhead crane. Use the following illustrations for correct guidance on safe handling and lifting techniques.

- Cut packaging straps first, before lifting.



**Ensure that the external silencers/mufflers are removed before attempting to lift the purifier.**

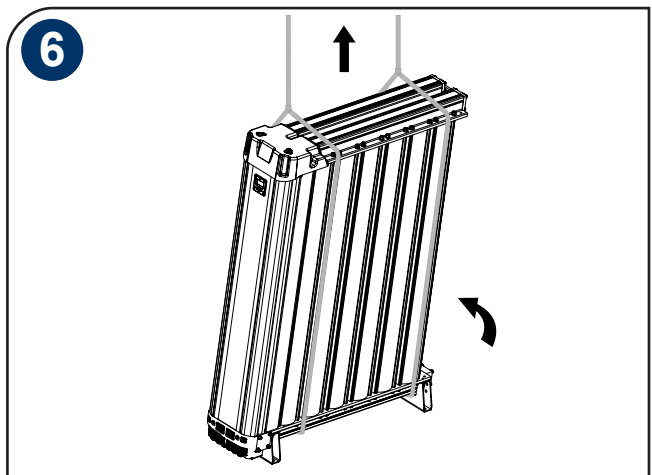
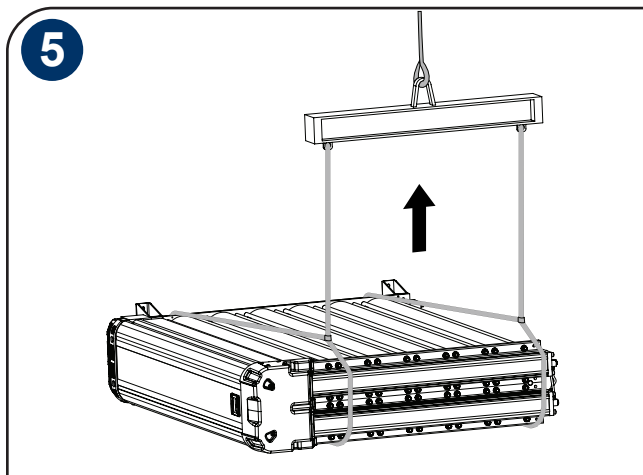
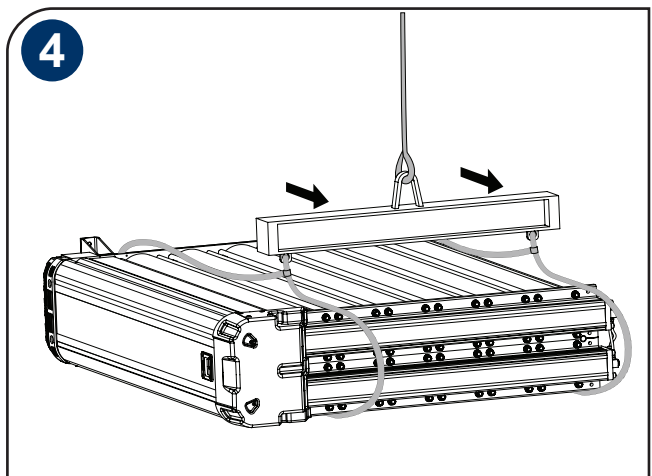
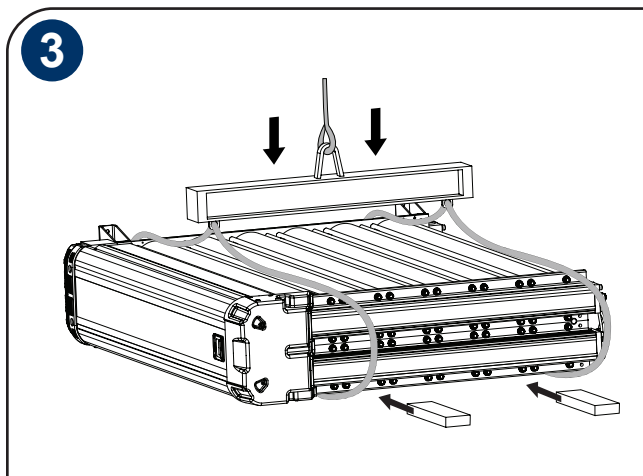
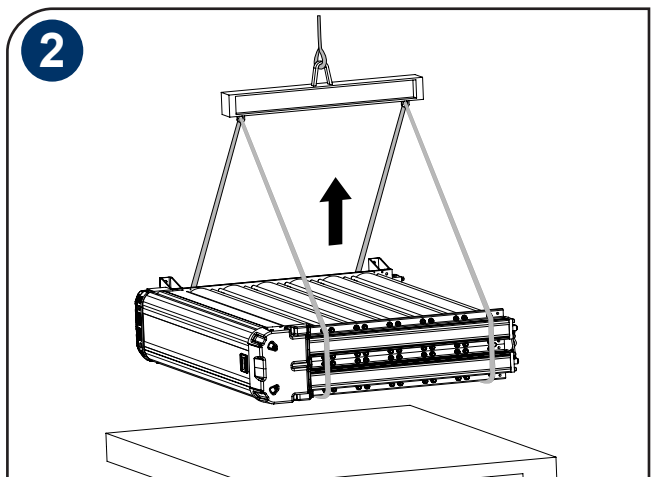
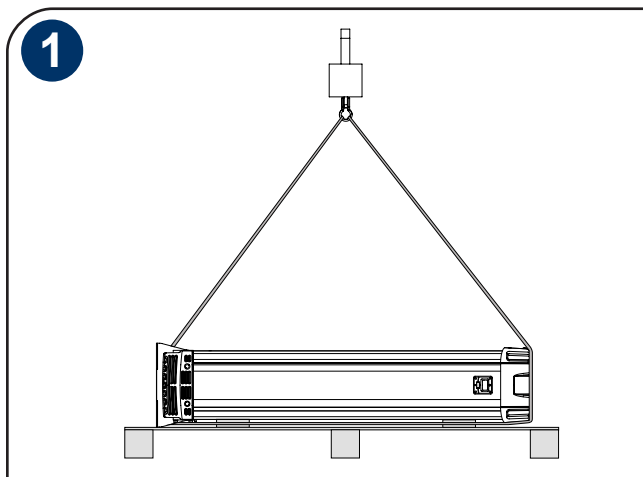

## 7. Product Dimensions

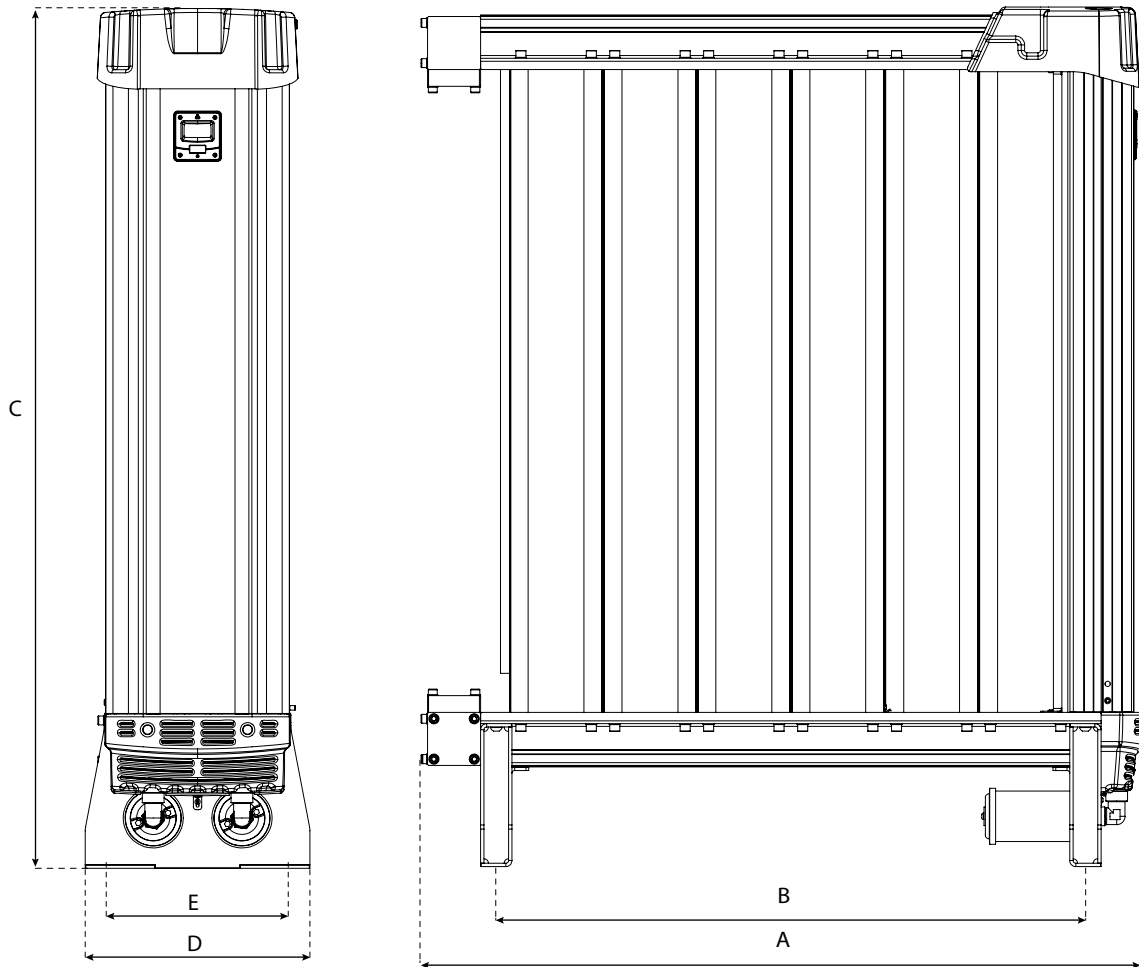

MODEL	CONNECTION	A ins (mm)	B ins (mm)	C ins (mm)	D ins (mm)	E ins (mm)	WEIGHT lbs (KG)
<b>NDL - 2110</b>	2" NPT	26 (678)	15 (382)	50 (1289)	16 (400)	14 (360)	366 (166)
<b>NDL - 2120</b>	2" NPT	26 (678)	15 (382)	60 (1538)	16 (400)	14 (360)	441 (200)
<b>NDL - 2130</b>	2" NPT	26 (678)	15 (382)	73 (1889)	16 (400)	14 (360)	547 (248)
<b>NDL - 3130</b>	2" NPT	31 (781)	21.6 (550)	73 (1889)	16 (400)	14 (360)	778 (353)
<b>NDL - 4130</b>	2.5" NPT	38 (949)	28 (718)	73 (1889)	16 (400)	14 (360)	1010 (548)
<b>NDL - 6120</b>	2.5" NPT	51 (1285)	41.5 (1054)	60 (1538)	16 (400)	14 (360)	1155 (524)
<b>NDL - 6130</b>	2.5" NPT	51 (1285)	41.5 (1054)	73 (1889)	16 (400)	14 (360)	1473 (668)

## 8. Equipment Overview

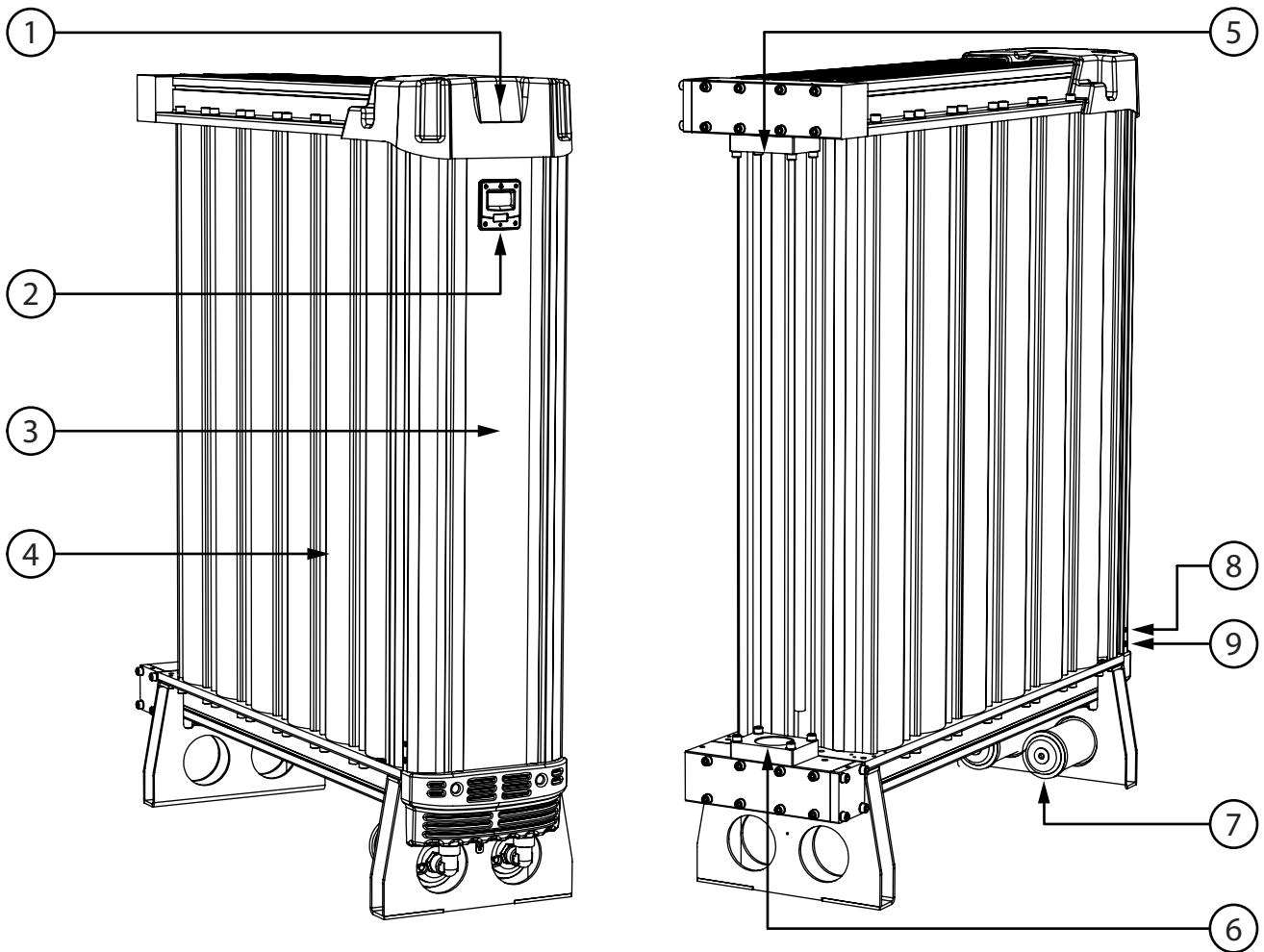

<b>1</b>	Dryer Top Cover
<b>3</b>	Front Shroud
<b>7</b>	External Silencers/Mufflers
<b>9</b>	Remote Stop/Start Control (if required)

<b>2</b>	Controller Display Unit
<b>4</b>	Dryer Column
<b>6</b>	Air Inlet
<b>8</b>	Mains Power

## 9. System Layout

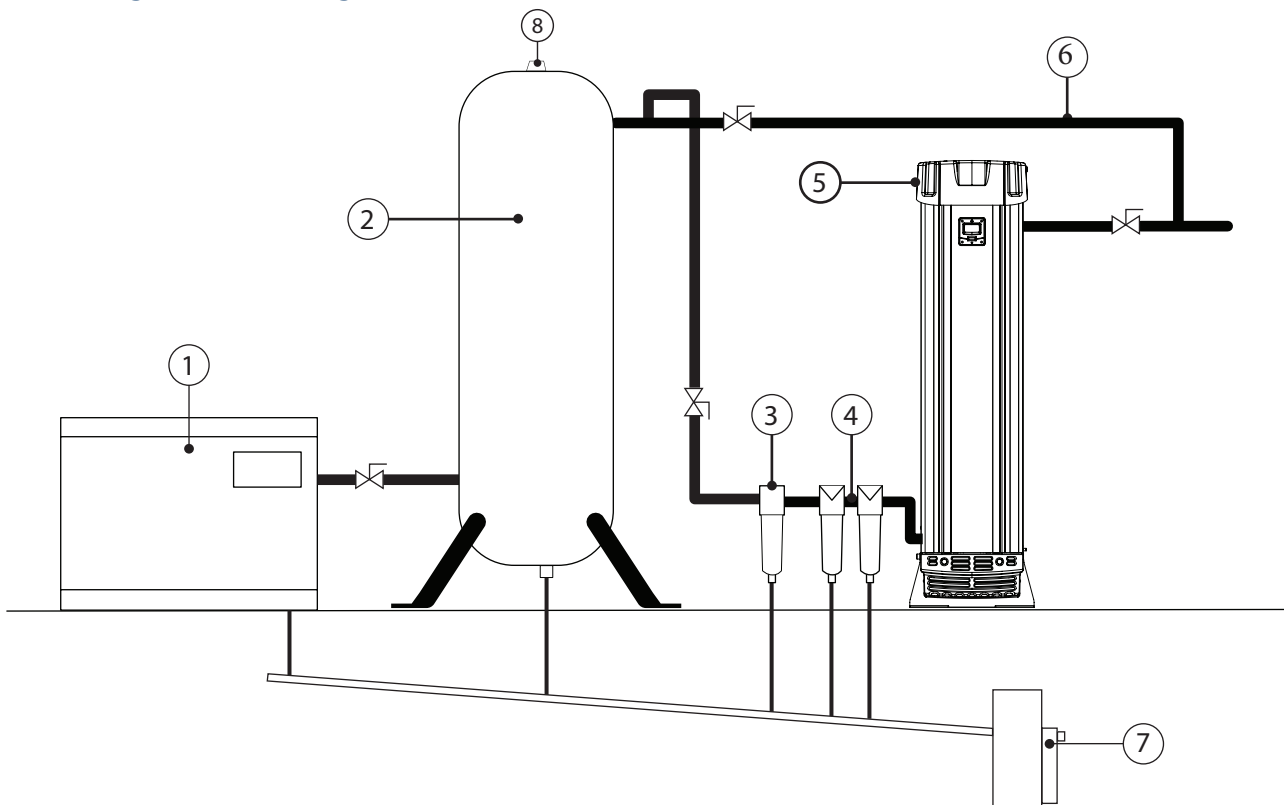

Ref	Description	Ref	Description
1	Compressor	5	Series 3 Dryer
2	Wet air receiver	6	Bypass line
3	Water separator	7	Oil / Water separator
4	Dryer pre-filtration	8	Pressure Relief Valve*

\*Note: It is the customer's responsibility to fit pressure relief valves to the compressed air system.

### 9.1. Site Location

When selecting an installation site for the dryer, ensure the following conditions are met:

- Installation site should be located indoors on a flat surface protected from the weather and other harmful conditions.
- The ambient temperature must not drop below 33.8°F (+1°C) or exceed 122°F (50°C).
- The installation site should be level and able to support the weight of the product.
- Ensure sufficient space around the product, to allow access for operation and maintenance.
- Take into account the noise generated by the dryer exhausting while in use when considering location.

## 10. Mechanical Installation

Once the dryer has been located into position, install ball valves and pipe work to ready the unit for connection to inlet and outlet pressure piping.

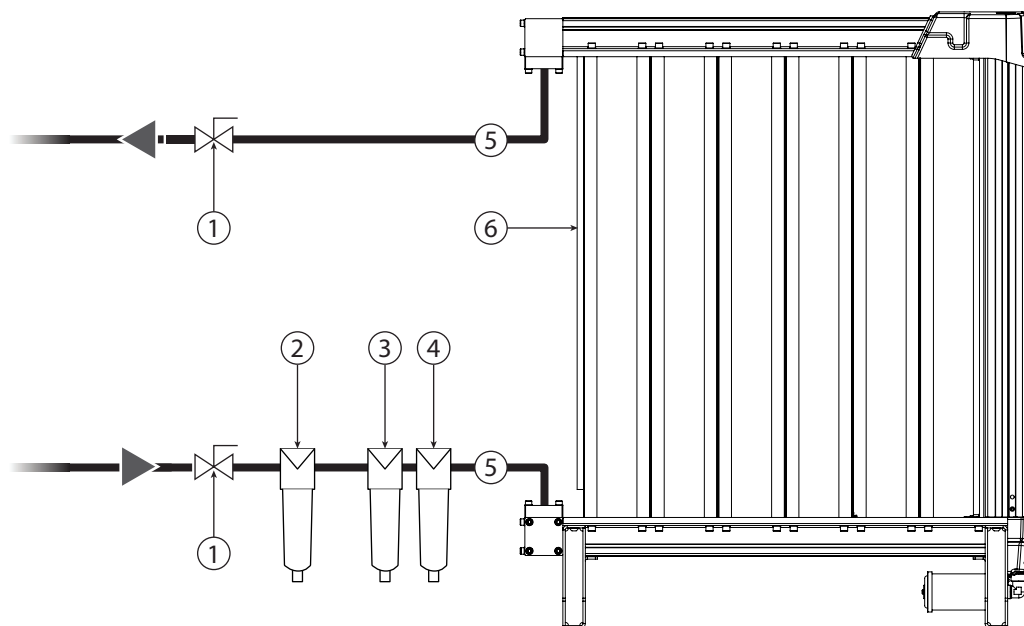

The diameter of the pipes must be sufficient to allow unrestricted inlet air supply to the dryer and to the application as shown in the table below.

Ref.	Description	Ref.	Description
1	Ball Valve	5	2" or 2.5" Piping (as required by the dryer)
2	Water Separator	6	Series 3 Dryer
3	Pre-filter (Inlet)		
4	High efficiency filter		

Pre and high efficiency filtration is recommended at the inlet to the dryer. In extreme conditions a water separator is recommended at the inlet.

Ensure that each filter condensate drain is suitably piped away and any effluent is disposed of in accordance with local regulations.

It is important to ensure that all piping materials are suitable for the application, clean and debris free. The diameter of the pipes must be sufficient to allow unrestricted inlet air supply to the equipment and outlet gas / air supply to the application.

The dryer is supplied with an integrated exhaust silencer.

All components used within the system must be rated to at least the maximum operating pressure of the equipment. It is recommended that the system be protected with suitably rated pressure relief valves. It is also recommended to install the dryer with a bypass to facilitate servicing.

# 11. Electrical Installation

## Mains Power Connection

To install the mains power cable:

1. Remove the two screws from the top cover and lift from the purifier.
2. Locate the two catches at the top and bottom of the shroud and pull them towards each other and open the shroud to expose the controller.
3. Remove the IEC plug from the controller
4. Unscrew the cap head screw to remove the plug top cover.
5. Feed the mains power cable through the holes located on the bottom of the shroud.
6. Wire the mains power cable into the IEC plug (see figure 2).
7. Once the mains cable is correctly wired into the IEC plug, reattach the plug into its socket.

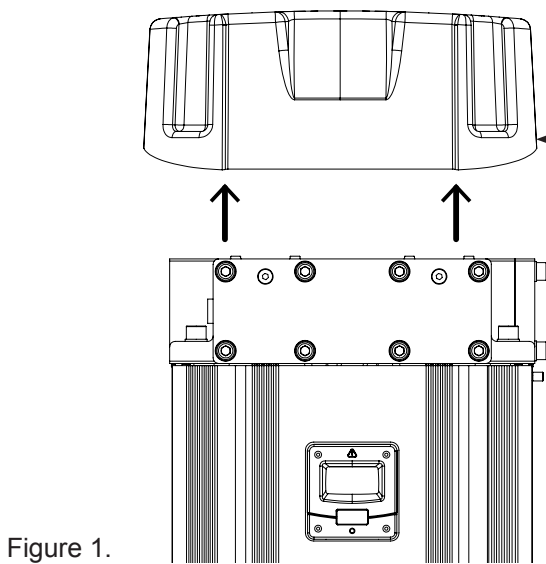

Figure 1.

### Electrical Power Requirements

Supply: 100 - 240VAC  
 50 -60 Hz  
 Input Current: 1.3 / 0.8A  
 (115/230 VAC)

Top Cover  
 Shroud Latches  
 Controller

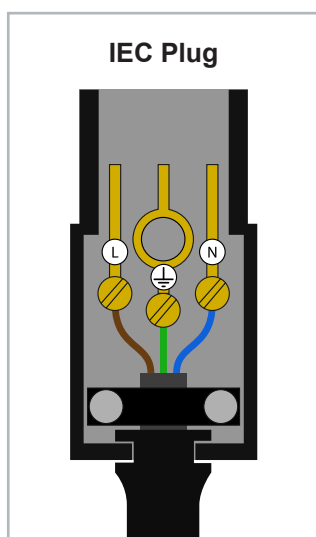
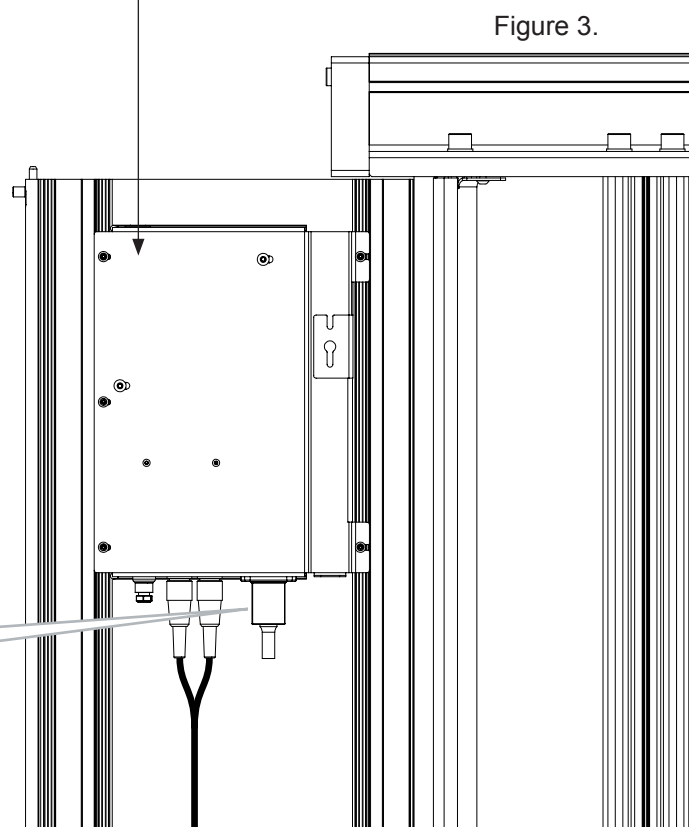

Figure 2.



## 12. Dryer Operation

Locate the electrical connector on the underside of the controller in the shroud.

### Dryer Remote Stop/Start Control (if required)

- To set up for remote control eco mode. Remove the link between pins 1 and 4 (3) in the electrical connector plug. A zero volt switching signal from the remote control needs to be connected between pins 1 and 4 (4).
- When the connection is made, the dryer will operate normally. If the connection is broken, i.e. the purifier has been remotely switched off, the dryer will stop cycling and go into standby mode, displaying “STANDBY” on the display once completed.
- Using remote stop / start ensures the correct shut-down sequence is implemented.

Electrical Connector

Figure 1.

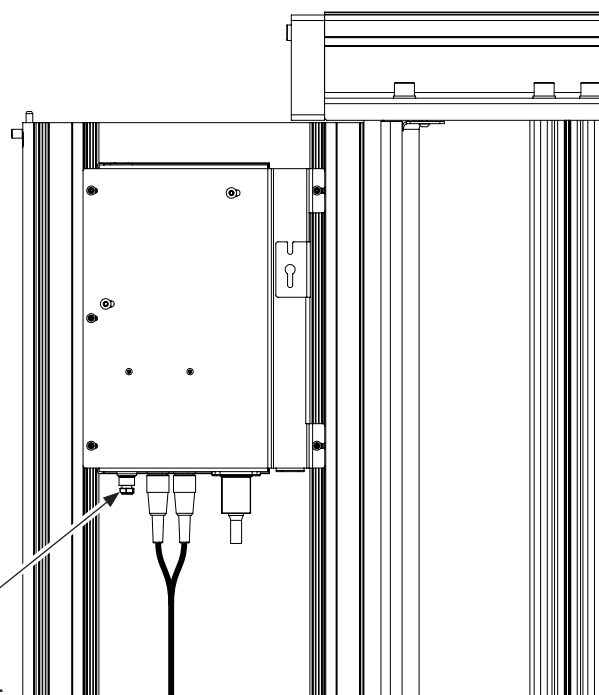

### 8.1 6 Pin Electrical Connector Configuration

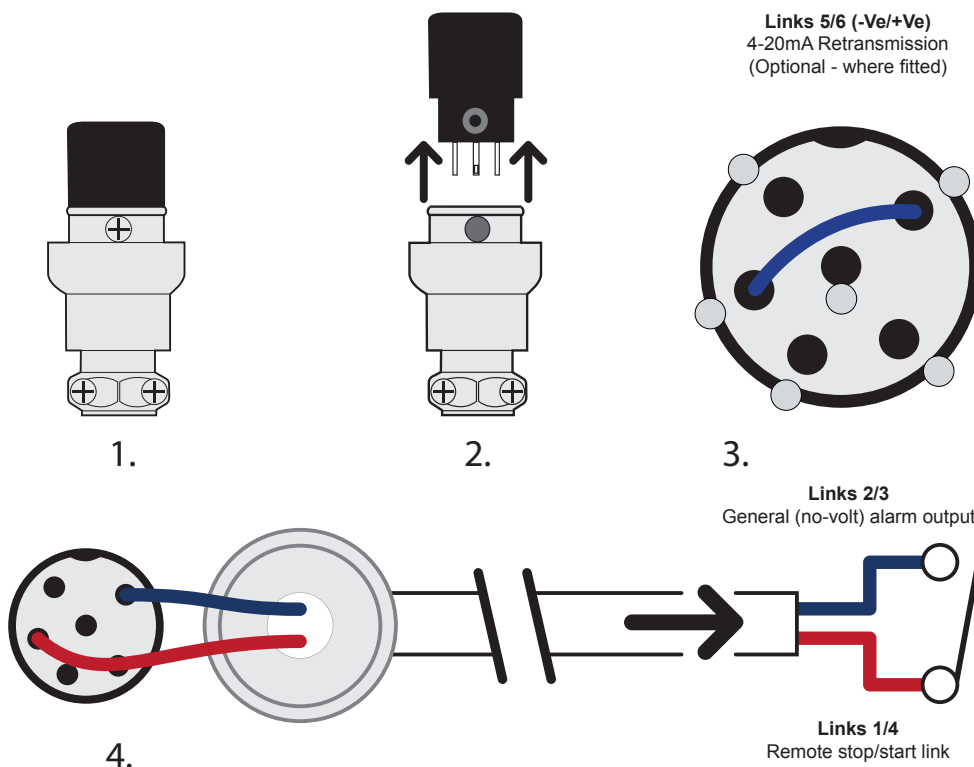

**Under no circumstances should external voltage/current be applied to pins 1 and 4, damage to the controller will occur, negating the warranty.**

## 12.2. Dryer Start-up

- Ensure the purifier is securely hardwired into the power source.



**Do not allow the dryer to flow air unless powered up, switched on and cycling. Resulting effect could be bed contamination; requiring replacement cartridges.**



**Ensure that the external silencers/mufflers are re-installed before attempting to start the dryer.**

- Connect all pipe work.
- Ensure the inlet operating pressure parameters are between 80 - 145 psig (5.5 - 10 barg).
- Ensure the inlet air temperature is between 35°F - 86°F (1.5 - 30°C).
- Slowly open the inlet valve until fully open and allow dryer to pressurize.
- Turn on the power to the dryer.
- Open the outlet valve.
- The dryer will display its status and commence normal operation.

### 12.3. Monitoring dryer performance (Energy saving option)

- The dew-point is displayed on the control panel. When the dew-point displayed is better than  $-54^{\circ}\text{F}$  PDP the dryer will switch into economy mode and stop cycling. When the dew-point degrades to  $-43^{\circ}\text{F}$  the dryer will restart cycling ensuring the dew-point is maintained at or better than  $-40^{\circ}\text{F}$ .
- If the dryer fails to achieve dew-point (falls below  $-22^{\circ}\text{F}$ ) the alarm output will be indicated on the front screen and the remote alarm output will activate.



*Beware this is only an example as the dew-point set-points and alarms are adjustable through the display panel.*

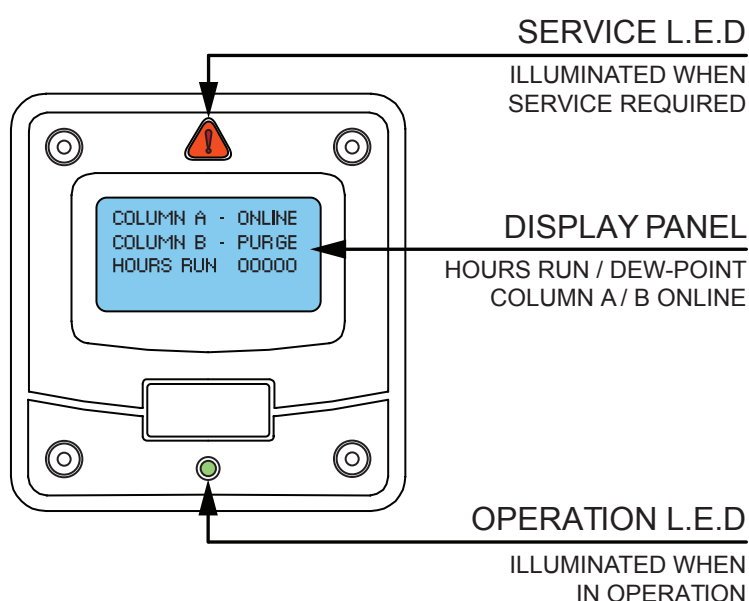

### 12.4. Shutdown Procedure

- Close the inlet and outlet valves.



**The dryer will still be pressurized! In order to depressurize the dryer; ensure the dryer is isolated from the compressed air supply source:**

- Cycle the dryer at least twice to ensure the dryer exhausts and is completely depressurized.
- When fully depressurized the 'clicking' of the exhaust valves will be heard but no air exhausted.
- When the dryer is fully depressurized, isolate from the power supply.

## 13. Maintenance



Maintenance operations should only be carried out by authorized, suitably trained personnel.

### 13.1. Maintenance Guidelines

- Maintenance operations only to be conducted when the system has been shut down and fully depressurized.
- All connections must be undone with care, paying particular attention to the areas that become pressurized.
- Do not modify or adjust the control settings.
- Only certified n-psi approved replacement parts to be used.
- Always check all connections for leakage and secure seating.
- Ensure all loose parts are removed or secured to the dryer before operation.

### 13.2. Cleaning

Clean the equipment with a damp cloth only and avoid excessive moisture around any electrical sockets. If required a mild detergent may be used, however do not use abrasives or solvents as they may cause damage.

### 13.3. Daily Checks

Visual and functional check of the dryer should be carried out daily:

- Check the dryer for any external damage.  
**Assess and eliminate any defects found.**
- If the red service light appears, the dryer must be serviced.  
**Contact the service department and request a dryer service kit.**
- Remove any loose dust or dirt from the dryer; clean all surfaces that appear to have attracted unwanted contaminants.
- Check the dewpoint sensor display (if installed). If the dewpoint is not maintained at  $<-22^{\circ}\text{F}$  the reading on the display will alternate with “dewpoint alarm” every 5 seconds. The no-volt alarm will also activate.  
**Contact the service department and request a product service.**

## 14. Servicing



**Maintenance operations should only be carried out by authorized, competent and suitably trained personnel.**

### 14.1. Servicing Guidelines

- Maintenance operations only to be conducted when the system has been shut down, fully depressurized and isolated completely from the compressed air and electrical supply.
- Ensure the system is in a safe condition for maintenance to be carried out on.
- Dismantle and assemble with care, paying particular attention to the areas that become pressurized.
- All gaskets removed during maintenance operations must be replaced with new gaskets.
- Do not modify or adjust the control settings.
- Only certified n-psi approved replacement parts to be used.
- Always check all connections / sealing faces for cleanliness and secure seating prior to assembly.
- Ensure all components are refitted to the product before operation.
- Ensure the dryer is left operating in a safe working condition after completion of maintenance.

## 14.2. Service Procedures

A dryer service should take place every 2 years or 12,000 hours of operation (whichever occurs first). Service kits are available which include: replacement desiccant, integral filters, seals and valves.

### Service A - 12,000 hours (or 2 years) service.

- Replace Desiccant & integrated Afterfilters
- Replace ICF valves (inlet, outlet, exhaust)
- Replace all gaskets and seals removed while servicing the dryer (included in relevant service kits)

### Service B - 24,000 hours (or 4 years) service.

- Service as above
- Replace pilot valves

### Service C - 6,000 hours (or 1 year) service.

- Dewpoint sensor service – NSK-0130 (ES models only) – contact technical support at n-psi

MODEL	SERVICE A				SERVICE B
	Desiccant & Afterfilter Service Kit	Inlet Valve Kit	Outlet Valve Kit	Exhaust Valve Kit	Pilot Valve Kit
NDL - 2110	NDA 110 - 2	NVK D3 2	NVK D3 1	NVK D3 2	NVK 0100
NDL - 2120	NDA 120 - 2	NVK D3 2	NVK D3 1	NVK D3 2	NVK 0100
NDL - 2130	NDA 130 - 2	NVK D3 2	NVK D3 1	NVK D3 2	NVK 0100
NDL - 3130	NDA 130 - 3	NVK D3 2	NVK D3 1	NVK D3 2	NVK 0100
NDL - 4130	NDA 130 - 4	NVK D3 2	NVK D3 1	NVK D3 2	NVK 0100
NDL - 6120	NDA 120 - 6	NVK D3 2	NVK D3 1	NVK D3 2	NVK 0100
NDL - 6130	NDA 130 - 6	NVK D3 2	NVK D3 1	NVK D3 2	NVK 0100

## 14.3. Additional Kits

### ES Upgrade Kit:

Converts a standard dryer to an energy saving model.



*Please refer to the Series 3 Dryer service guide for instruction regarding carrying out a service.*

## 15. Troubleshooting

Problem	Problem Caused	Solution
<b>Poor dew point performance</b>	1. Insufficient inlet pressure	1. Inlet pressure min 58 psig (4 barg). If not adjust inlet pressure settings.
	2. Electrical Fault	2. Ensure the power is on and the dryer front panel is illuminated; check the dryer is cycling correctly.
	3. Moist or contaminated desiccant	3. Eliminate the cause of contamination. Replace desiccant – do not re-use.
	4. Too high air consumption	4. Ensure the performance of the dryer matches the required system air consumption.
	5. Excessive inlet air temperature	5. Check against technical specification.
	6. Insufficient purge air.	6. Purge incorrectly adjusted. Consult service personnel to adjust settings (Factory pre-set).
	7. Exhaust silencer blocked	7. Consult service personnel.
<b>Failure of dryer to cycle</b>	8. Controller not functioning correctly	8. Ensure the controller is powered; check the on screen column status to ensure it is powering the solenoid valves during normal cyclic operation.
	9. Controller not illuminated	9. Inlet pressure min 58 psig (4 barg). If not adjust inlet pressure settings.
	10. Insufficient inlet pressure	10. Check power to unit & fuse.
	11. Failure to de-pressurize when cycling.	11. Solenoid valve not functioning correctly; if there is power to the coil, replace valve. A correctly working valve outputs an audible click when it energizes.
	12. Outlet flow stops	12. Check inlet air supply.
<b>Constant depressurization</b>	13. Failure to initialize dryer	13. Switch off and restart dryer. Ensure dryer is pressurized before powering dryer to allow dryer to initialize before commencing operation.
	14. Erratic air flow from exhaust	14. Faulty or damaged valve; service required.

### Reference to known issue

#### Opening the inlet valve too quickly

Valve should be opened slowly allowing the pressure to build up gradually.

#### Inlet/outlet head pipe

Diameter too small.

Pipe work unsupported.

Inlet pipe work from low point in system, allowing bulk water to collect and enter the dryer.

#### Electrical controller

Incorrect fuse fitted or fuse blown. Check the plug and fuse located on top of the controller back plate inside the dryer front cover.

#### Additional Items

Use of non-authorized components.

Untrained / unauthorized maintenance / installation personnel used.

Increase in air consumption without relation to the flow capacity of the dryer.

Purging the dryer with cleaning agents that could damage the components or the desiccant.

Covers removed or loose during operation.

Failure to carry out a service when indicated by the dryer.

Do not allow the dryer to flow air unless powered up, switched on and cycling. Resulting effect could be desiccant contamination; requiring replacement desiccant.









**nano**  
**PURIFICATION SOLUTIONS**

**nano-purification solutions**

11330 Vanstory Drive  
Huntersville, NC 28078  
USA

Telephone: (704) 897-2182

Fax: (704) 897-2183

Internet: [www.n-psi.com](http://www.n-psi.com)

E-mail: [support@n-psi.com](mailto:support@n-psi.com)