

PRODUCT CATALOG

Performance ▾ Reliability ▾ Service



NAVAC® Inc.

1099 Wall Street W, Suite 179
Lyndhurst, NJ 07071
Tel/Fax: +1 877 MY-NAVAC
+1 877 696 2822
info@navacglobal.com
www.NavacVacuum.com

About NAVAC

NAVAC is the global leader in rotary vane vacuum pump manufacturing. With an impressive legacy of over 30 years at the forefront of vacuum pump technological advancements, NAVAC has consistently set the industry standard for innovation and quality. As the world's largest rotary vane pump manufacturer, we take pride in empowering our customers by providing them with cutting-edge solutions.

At NAVAC, we understand the evolving landscape of advanced vacuum technology and the challenges it presents. Our mission is to guide our customers through these challenges, helping them navigate the complexities and make informed choices. We believe in providing not just products but solutions that enable our customers to work with confidence.

PERFORMANCE, RELIABILITY & SERVICE are at the core of our values. We are committed to delivering unparalleled excellence in every aspect of our offerings. Whether you are in research and development, manufacturing, or any other industry that relies on advanced vacuum solutions, NAVAC is here to exceed your expectations.

Our Mission

We empower our customers to drive innovation for the future while helping them NAVIGATE advanced vacuum technology challenges and choices. Our focus on service, reliability, and performance will lead us beyond what we ever thought was possible.



TABLE OF CONTENT



EcoDrive eee.....	Page 03
DuoDrive eee	Page 07
ShieldDrive eee	Page 09
UniDrive eee	Page 11
HelixDrive eee	Page 15
BoostDrive eee	Page 17

EcoDrive

Dual-Stage, Oil-Sealed Rotary Vane Vacuum Pump

NAVAC

EcoDrive is a dual-stage, oil-sealed rotary vane vacuum pump equipped with a high-efficiency Permanent Magnet motor. With a new advanced feature, "Eco Mode", the pump runs at peak efficiency, optimizing both energy consumption and noise. This technology is ideal for industrial applications due to its performance and reliability, ensuring long-term productivity.



- ▶ **Gas Ballast**
Adjustable gas ballast allows for the different requirements of condensable gas to be exhausted.
- ▶ **Oil**
Proprietary mineral oil included with the pump. All models can also be prepped with high performance PFPE.
- ▶ **Anti-Suck Back Design**
Protects vacuum system from backstreaming oil contamination in the event of an unexpected shut down.

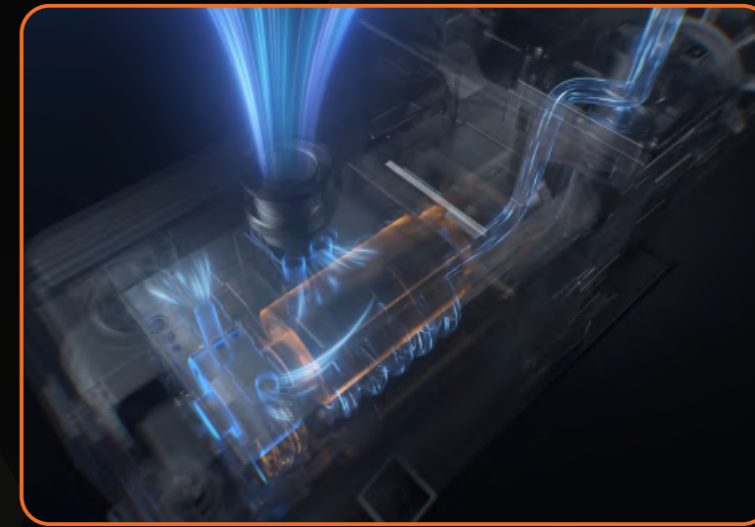

- ▶ **Permanent Magnet Motor**
Advanced motor design allows for low energy consumption in the quietest environments.
- ▶ **Fast Pumping Speed**
ED30 provides the fastest pumping speed with the lowest energy consumption.
- ▶ **Proprietary Coating**
Special coating helps protect against corrosive environment.



ED8

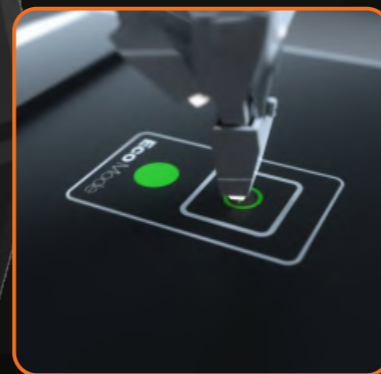

- ▶ **Eco Mode**
The pump is equipped with variable-frequency motor, and the Eco Mode allows the pump to run at peak efficiency, optimizing both energy consumption and noise.



ED30

- ▶ **Corrosion Resistant**

EcoDrive Series ED16, ED24, ED30 are designed with a proprietary coating to perform in corrosive applications.

EcoDrive

▼ Dual-Stage, Oil-Sealed Rotary Vane Vacuum Pump

SPEC		ED4	ED8	ED12
Pumping Speed (60Hz)	m ³ /h (CFM)	4 (2.4)	8 (4.7)	10 (5.9)
Ultimate Total Pressure without Gas Ballast	mbar (Torr)	5x10 ⁻³ (3.7x10 ⁻³)	8x10 ⁻³ (6x10 ⁻³)	8x10 ⁻³ (6x10 ⁻³)
Ultimate Total Pressure with Gas Ballast	mbar (Torr)	2 (1.5)	2 (1.5)	2 (1.5)
Power Supply		Single Phase	Single Phase	Single Phase
Power Rating	kW	0.37	0.37	0.37
Motor Speed	rpm	1500	1500	1850
Inlet/Outlet		KF25	KF25	KF25
Oil Capacity	L	1	1	1
Noise Level	dB	≤53	≤53	≤53
Weight	lbs	29.7	32	32
Dimensions (L*W*H)	in	16.3x6x12.2	16.3x6x12.2	16.3x6x12.2

Dimensions

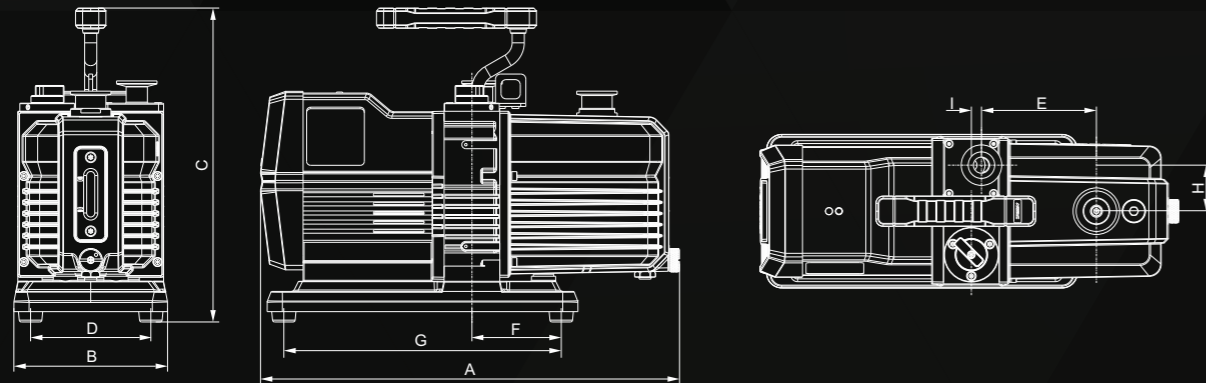

Model	A	B	C	D	E	F	G	H	I	Inlet	Outlet
ED4	16.3	6	12.2	4.7	4.5	3.4	10.7	1.8	0.4	KF25	KF25
ED8	16.3	6	12.2	4.7	4.5	3.4	10.7	1.8	0.4	KF25	KF25
ED12	16.3	6	12.2	4.7	4.5	3.4	10.7	1.8	0.4	KF25	KF25

EcoDrive

Dual-Stage, Oil-Sealed Rotary Vane Vacuum Pump ▼

SPEC		ED16	ED24	ED30
Pumping Speed (60Hz)	m ³ /h (CFM)	16 (9.4)	24 (14)	30 (18)
Ultimate Total Pressure without Gas Ballast	mbar (Torr)	8x10 ⁻³ (6x10 ⁻³)	8x10 ⁻³ (6x10 ⁻³)	8x10 ⁻³ (6x10 ⁻³)
Ultimate Total Pressure with Gas Ballast	mbar (Torr)	8x10 ⁻² (6x10 ⁻²)	8x10 ⁻² (6x10 ⁻²)	8x10 ⁻² (6x10 ⁻²)
Power Supply		Single Phase	Single Phase	Single Phase
Power Rating	kW	1.1	1.1	1.1
Motor Speed	rpm	1500	1500	1500
Inlet/Outlet		KF25	KF25	KF25
Oil Capacity	L	2.2	2.2	2.2
Noise Level	dB	≤58	≤58	≤58
Weight	lbs	62	64	66
Dimensions (L*W*H)	in	23.9x7.4x11.8	23.9x7.4x11.8	23.9x7.4x11.8

Dimensions

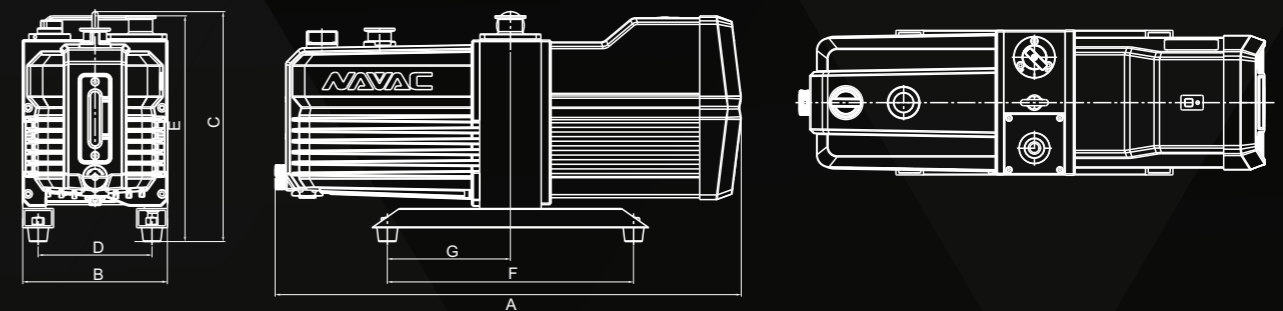

Model	A	B	C	D	E	F	G	Inlet	Outlet
ED16	23.9	7.4	11.8	5.8	11.5	12.6	6.3	KF25	KF25
ED24	23.9	7.4	11.8	5.8	11.5	12.6	6.3	KF25	KF25
ED30	23.9	7.4	11.8	5.8	11.5	12.6	6.3	KF25	KF25

DuoDrive

Dual-Stage, Oil-Sealed Rotary Vane Vacuum Pump

DuoDrive is a dual-stage, oil-sealed rotary vane vacuum pump equipped with a traditional AC motor. True to its legacy, the DuoDrive has been coined as the “workhorse” in the industrial vacuum market. Its proprietary coating protects the pump from the most demanding industrial applications.



- ▶ **Gas Ballast**
Adjustable gas ballast allows for the different requirements of condensable gas to be exhausted.
- ▶ **Oil**
Proprietary mineral oil included with the pump. All models can also be prepped with high performance PFPE.
- ▶ **Anti-Suck Back Design**
Protects vacuum system from backstreaming oil contamination in the event of an unexpected shut down.



DD65

▶ Corrosion Resistant

DuoDrive Series pumps are designed with a proprietary coating to perform in corrosive applications.

DuoDrive

Dual-Stage, Oil-Sealed Rotary Vane Vacuum Pump ▼

SPEC		DD48	DD65
Pumping Speed (50/60Hz)	m ³ /h (CFM)	48 (28) / 56 (33)	65 (38) / 78 (46)
Ultimate Total Pressure Gas Ballast Close	mbar (Torr)	8x10 ⁻³ (6x10 ⁻³)	8x10 ⁻³ (6x10 ⁻³)
Ultimate Total Pressure Gas Ballast Open	mbar (Torr)	8x10 ⁻² (6x10 ⁻²)	8x10 ⁻² (6x10 ⁻²)
Power Supply		Three Phase	Three Phase
Power Rating	kW	1.5	2.2
IP Level		IP44	IP44
Motor Speed (50/60Hz)	rpm	1440/1720	1440/1720
Inlet/Outlet		KF40	KF40
Oil Capacity	L	4	4
Noise Level (50/60Hz)	dB	≤65/71	≤65/73
Weight	lbs	136.7	143.3
Dimensions (L*W*H)	in	28.7x9.2x14	28.7x9.2x14

Dimensions

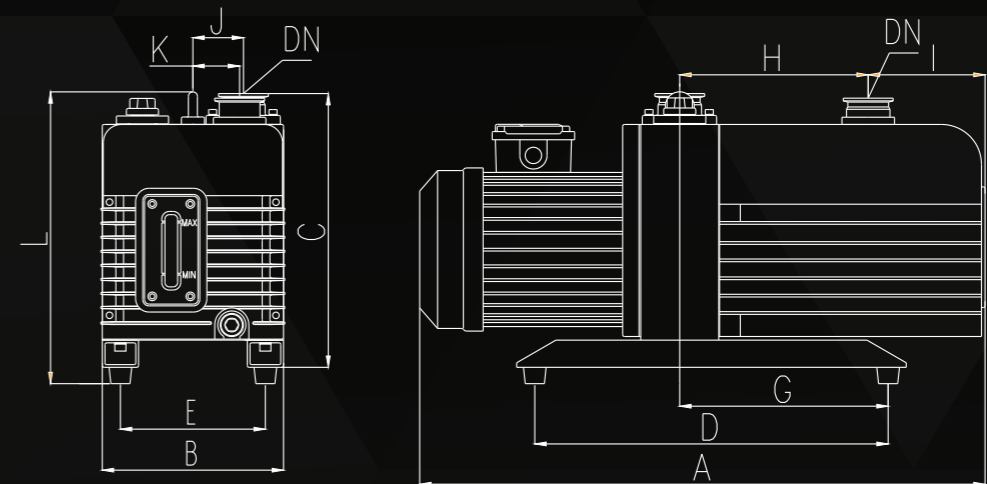

Unit: inch

Model	A	B	C	D	E	G	H	I	J	K	L	Inlet	Outlet
DD48	28.7	9.2	14.1	15.6	7.5	7.9	8.8	6.2	2.7	2.2	15.4	KF40	KF40
DD65	28.7	9.2	14.1	15.6	7.5	7.9	8.8	6.2	2.7	2.2	15.4	KF40	KF40

ShieldDrive

Dual-Stage, Oil-Sealed Rotary Vane Vacuum Pump

ShieldDrive is a dual-stage, oil-sealed rotary vane vacuum pump with a Permanent Magnet motor optimized for efficiency and leak-free operation. It employs static sealing with a mechanical shield and magnetic coupling designs, offering complete protection against oil migration. Ideal for laboratory use, its robust design guarantees leak-free performance in critical applications.

▶ Leak Free Operation

Magnetic shield design enhances connection between motor and pump to ensure leak-free operation.

▶ Corrosion-Resistant

Designed with a proprietary coating to perform in corrosive applications.

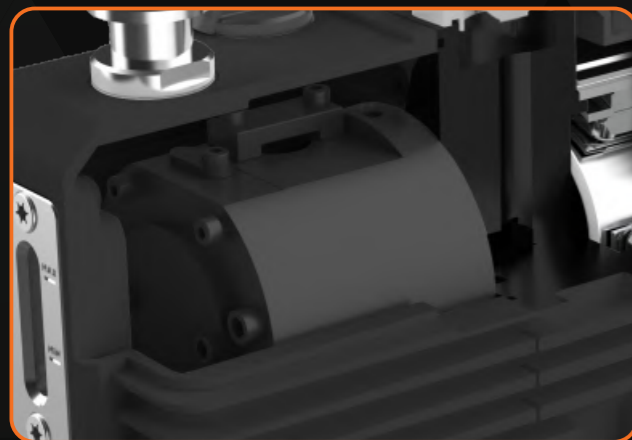

▶ Gas Ballast

Adjustable gas ballast allows for the different requirements of condensable gas to be exhausted.

▶ Oil

Proprietary mineral oil included with the pump. All models can also be prepped with high performance PFPE.

▶ Anti-Suck Back Design

Protects vacuum system from backstreaming oil contamination in the event of an unexpected shut down.

▶ Eco Mode

The pump is equipped with variable-frequency motor, and the Eco Mode allows the pump to run at peak efficiency, optimizing both energy consumption and noise.



SD12

SD2

ShieldDrive

Dual-Stage, Oil-Sealed Rotary Vane Vacuum Pump ▼

SPEC		SD2	SD8	SD12
Pumping Speed (60Hz)	m ³ /h (CFM)	2.5 (1.5)	8 (4.7)	10 (5.9)
Ultimate Total Pressure without Gas Ballast	mbar (Torr)	5x10 ⁻³ (3.7x10 ⁻³)	5x10 ⁻³ (3.7x10 ⁻³)	5x10 ⁻³ (3.7x10 ⁻³)
Ultimate Total Pressure with Gas Ballast	mbar (Torr)	3x10 ⁻² (2.2x10 ⁻²)	3x10 ⁻² (2.2x10 ⁻²)	3x10 ⁻² (2.2x10 ⁻²)
Power Supply		Single Phase	Single Phase	Single Phase
Power Rating	kW	0.25	0.37	0.37
Motor Speed		1800	1500	1850
Inlet/Outlet	rpm	KF16	KF25	KF25
Oil Capacity	L	0.33	1	1
Noise Level	dB	≤50	≤52	≤53
Weight	lbs	22	33	33
Dimensions (L*W*H)	in	12.2x4.5x6.6	16.3x6x9.3	16.3x6x9.3

Dimensions

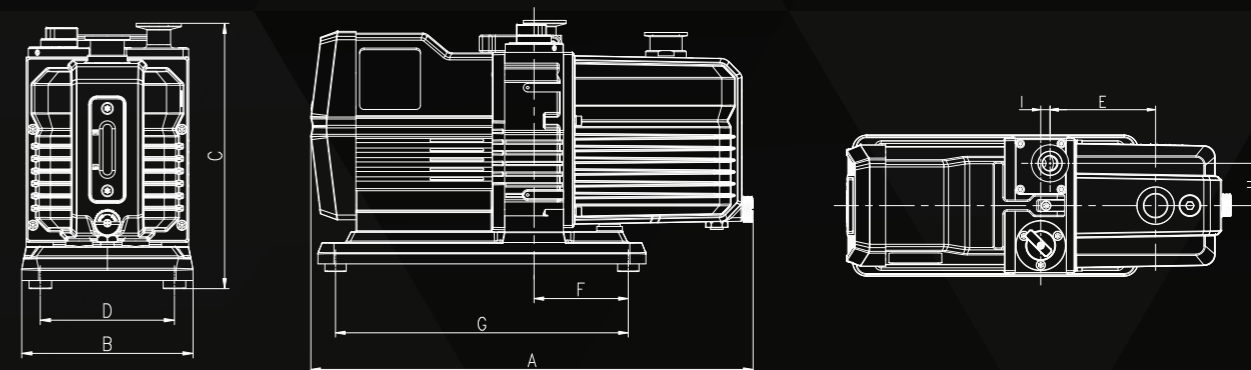

Unit: inch

Model	A	B	C	D	E	F	G	H	I	Inlet	Outlet
SD2	12.2	4.5	6.6	3.6	3.7	2.9	7.5	0.95	/	KF16	KF16
SD8	16.3	6	9.3	4.7	4.5	3.4	10.7	1.8	0.4	KF25	KF25
SD12	16.3	6	9.3	4.7	4.5	3.4	10.7	1.8	0.4	KF25	KF25

UniDrive

Single-Stage, Oil Sealed Rotary Vane Vacuum Pump

UniDrive is a single-stage, oil-sealed rotary vane vacuum pump optimized for applications with high moisture content. Engineered with performance in mind, UniDrive offers unmatched reliability for industries such as food processing and packaging.



- Integrated Oil Mist Filter**
 High efficiency oil mist filters prevent oil vapor exhausting into the equipment space and smoking while also prolonging the service life.
- Gas Ballast**
 Adjustable gas ballast allows for the different requirements of condensable gas to be exhausted.
- Proprietary Motor**
 In-house designed and manufactured AC motor provides longevity and robust operation.



UniDrive

Single-Stage, Oil-Sealed Rotary Vane Vacuum Pump ▼

SPEC		UD20	UD65	UD100	UD300
Pumping Speed (50/60Hz)	m ³ /h (CFM)	22 (13), 60Hz	55 (32) / 65 (38)	100 (59) / 120 (71)	300 (177), 60Hz
Ultimate Pressure	w. Gas Ballast	mbar (Torr)	/	0.3 (0.22)80	0.1 (0.075)
	w. Gas Ballast I	mbar (Torr)	1.6 (1.2)	0.5 (0.37)	0.2 (0.15)
	w. Gas Ballast II	mbar (Torr)	/	2 (1.5)	1 (0.75)
Water Vapor Tolerance	w. Gas Ballast I	mbar (Torr)	15 (11)	15 (11.3)	30 (22.5)
	w. Gas Ballast II	mbar (Torr)	/	30 (22.5)	50 (37.5)
Power Supply		Single Phase	Three Phase	Three Phase	Three Phase
Power Rating	kW	0.75	1.5	3	7.5
IP Level		IP54	IP54	IP54	IP54
Motor Speed (50/60Hz)	rpm	3440 (60Hz)	1440/1720	1440/1720	1440/1720
Inlet/Outlet		G1/2" G3/4"/-	G1-1/4"/G1-1/4"	G1-1/4"/G1-1/4"	G2"/G2"
Oil Capacity	L	0.45	2.5	2.5	8
Noise Level (50/60Hz)	dB	≤70.5 (60Hz)	≤65/67	≤65/67	≤79(60Hz)
Weight	lbs	43	93.7	158.7	474
Dimensions (L*W*H)	in	12.5x9.8x8.6	21.8x12.2x10.6	27.7x16x11.3	40.7x21.2x17.1

Dimensions

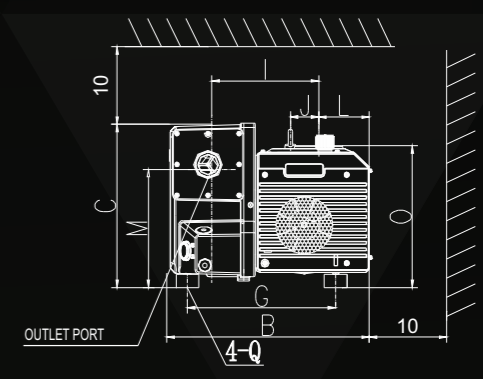
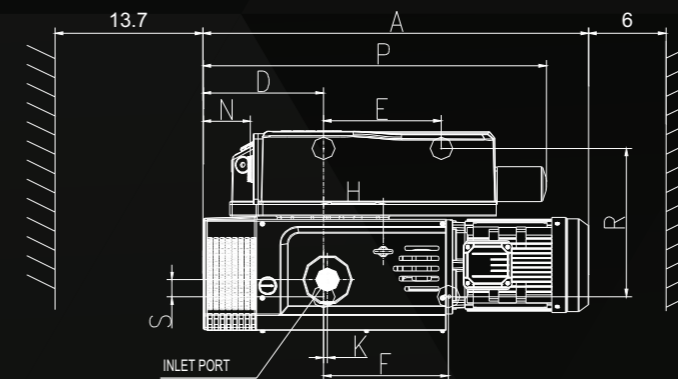

Unit: inch

Model	A	B	C	D	E	F	G	H	I	J	K	L	M	N	O	P	Q	R	S	Inlet	Outlet
UD20	12.5	9.8	8.6	3	5.5	4.3	5.2	/	5	/	0.6	2.8	6.2	0.8	7.2	11.8	M8	4.8	0.2	G1/2" G3/4"	/
UD65	21.8	12.2	10.6	5.9	8.5	7.8	10	2.3	7.4	2	0.2	2.8	8	1.3	9.9	18.3	M8	9.5	1.3	G1-1/4"	G1-1/4"
UD100	27.7	16	11.3	6.5	8.9	8.9	12.6	5.2	8.9	1.7	1.1	3.6	8.7	2.4	11	22.8	M10	10.2	1.6	G1-1/4"	G1-1/4"
UD300	40.7	21.3	17.1	12.8	12.3	13	15.5	16.3	11.2	3	0.4	5.3	12.4	5.2	14.8	38	M10	15.5	1.8	G2"	G2"

UniDrive LC-MS

Single-Phase, Single-Stage Oil Sealed Rotary Vane Vacuum Pump Designed for mass spectrometers

UniDrive LC-MS is a single-phase, single-stage, oil-sealed rotary vane vacuum pump optimized for Liquid chromatography–mass spectrometry. Designed to complement your LC-MS system, UniDrive LC-MS offers a compact design as well as noise reduction; Optimal for laboratory environments.



► **Optimal for Laboratory**

Designed with quiet operation in mind, these pumps are ideal for low noise environments, perfect for laboratory use.

► **Integrated Oil Mist Filter**

High efficiency oil mist filters prevent oil vapor exhausting into the equipment space while also prolonging the service life.

► **Gas Ballast**

Adjustable gas ballast allows for the different requirements of condensable gas to be exhausted.



UDS75

► **Single Phase**

UniDrive LC-MS

Single-Phase, Single-Stage Oil Sealed Rotary Vane Vacuum Pump
Designed for Mass Spectrometers

UDS55

UDS75

SPEC		UDS55	UDS75
Pumping Speed (60Hz)	m ³ /h (CFM)	50 (30)	70 (41)
Ultimate Pressure	mbar (Torr)	≤0.15 (0.11)	≤0.15 (0.11)
Power Supply		Single Phase, 220V/50-60Hz	Single Phase, 220V/50-60Hz
Power Rating	kW	1.5	1.5
Motor Speed	rpm	1400	1800
Inlet/Outlet		KF40/KF25	KF40/KF25
Oil Capacity	L	2.5	2.5
IP Rating		IP20	IP20
Noise Level	dB	≤63	≤65
Weight	lbs	121.2	121.2
Dimensions (L*W*H)	in	21.5x12.7x14.6	21.5x12.7x14.6

Dimensions

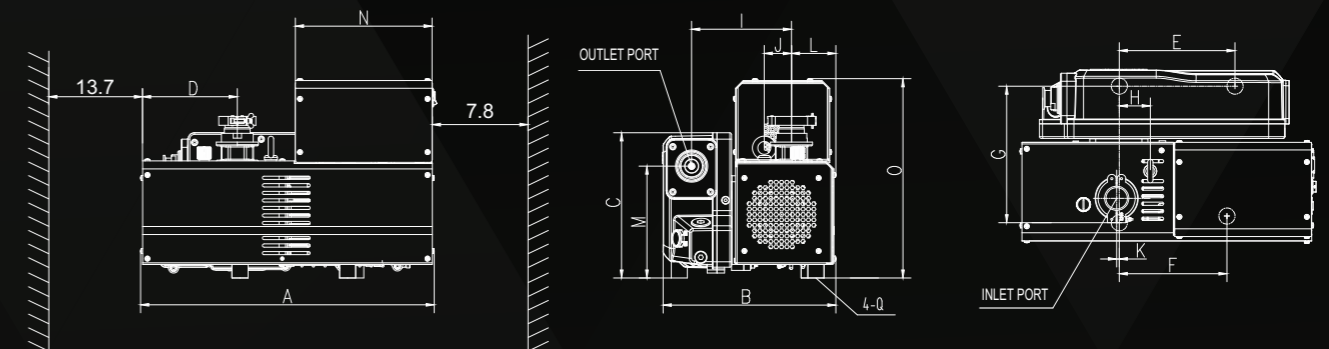

Unit: inch

Model	A	B	C	D	E	F	G	H	I	J	K	L	M	N	O	Q	Inlet	Outlet
UDS55	21.5	12.7	10.6	6.9	8.5	7.9	9.3	2.3	7.3	2	0.2	3.3	8.2	10	14.6	M8	KF40	KF25
UDS75	21.5	12.7	10.6	6.9	8.5	7.9	9.3	2.3	7.3	2	0.2	3.3	8.2	10	14.6	M8	KF40	KF25

HelixDrive

Ultra-Compact, Oil-Free Dry Screw Vacuum Pump

HelixDrive is an ultra-compact, oil-free dry screw vacuum pump. Its unique coaxial design, with an integrated motor, enhances both efficiency and reliability. Its proprietary coating protects the pump from the most demanding industrial applications. Ideal for harsh applications where oil is not tolerated.



- ▶ **Temperature Management**
Our temperature management system is optimized for the most effective cooling. Our larger pumps are water-cooled to enhance the performance of the pump while our smaller pumps are air cooled for easy operation.
- ▶ **Energy Efficiency**
Equipped with Permanent Magnet motor, HD20 and HD40 are the most efficient dry pumps in their class.
- ▶ **Water Vapor Handling**
HelixDrive pumps are robust and durable. They have excellent moisture handling capacities.
- ▶ **Compact Design**
As one of the most innovative designs, this dry screw pump delivers fast pumping speed in an ultra compact package.

- ▶ **Oil Free Operation**
Ideal for harsh applications where oil is not tolerated.



HelixDrive

Ultra-Compact, Oil-Free Dry Screw Vacuum Pump ▼

SPEC		HD8	HD20	HD40	HD80	HD100
Pumping Speed(60Hz)	m ³ /h	8	20	32	80	100
Ultimate Pressure	Pa	1	1	1	3	3
Gas purge	Dry Nitrogen/Dry Compressed Air	slm	0~100	0~100	0~180	0~60
	Pressure	Mpa	0.04~0.07	0.04~0.07	0.015~0.02	0.015~0.02
	Joint	/	Quick joint for air pipe Φ6mm			
Rated power	kW	1.8	1.8	1.8	3	3
Current at Ultimate Pressure	A	6	7	8	3	4
Peak Current	A	13	13	13	6	7
PID Functions		Yes				
Analog Input		Yes				
Communication Function		MODBUS-RTU				
Inlet/Outlet		KF25/KF16	KF25	KF25	KF40	KF40
Water Vapor Treatment Capacity	g/h	135	200	200	800	800
Cooling Mode		Air Cooling			Water Cooling	
Ambient Temperature		5°C-40°C				
Noise	dB	≤58	≤60	≤60	≤65	≤65
Weight	lbs	83.7	105.8	105.8	452	452
Dimensions (L*W*H)	in	20.5x11.8x12.6	23.6x11.8x12.6	23.6x11.8x12.6	35.4x18.3x21.6	35.4x18.3x21.6

Dimensions

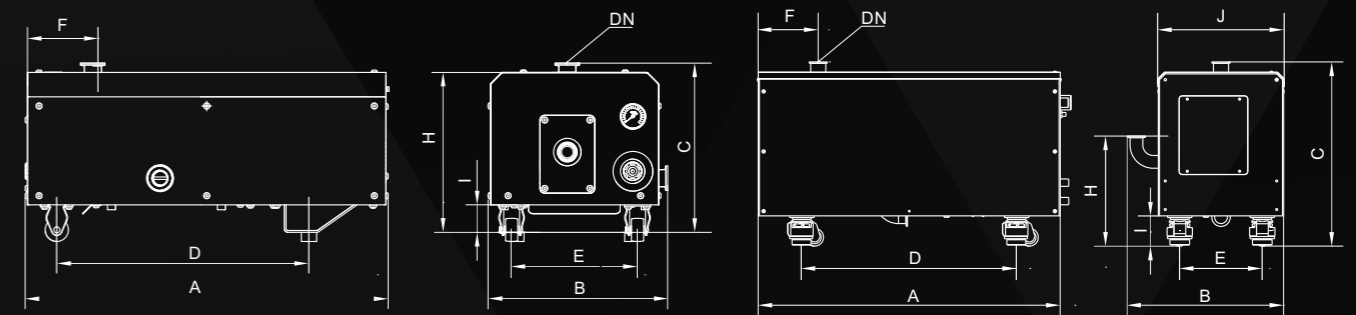

Unit: inch

Model	A	B	C	D	E	F	H	I	J	Inlet/Outlet
HD8	20.5	11.8	12.6	13.5	8.2	4.2	11	2.3	/	KF25
HD20	23.6	11.8	12.6	16.3	8.2	4.2	11	2.3	/	KF25
HD40	23.6	11.8	12.6	16.3	8.2	4.2	11	2.3	/	KF25
HD80	35.4	18.3	21.6	25.2	9.7	7	13	3.5	14.8	KF40
HD100	35.4	18.3	21.6	25.2	9.7	7	13	3.5	14.8	KF40

BoostDrive

High-Speed Roots-Style Vacuum Blower

BoostDrive is a high-speed roots-style blower designed to enhance your backing pump in a compact design. With performance in mind, pump downtime is decreased while optimizing ultimate vacuum pressure. This unique design makes it an excellent choice for various industries including chemical processing, pharmaceutical manufacturing, and semi-conductor coating.



▶ Performance

With pumping speed up to 600 m³/h, this roots-style blower will outperform pumps twice its size.

▶ Compact Design

As one of the most innovative designs, this dry roots-style blower delivers fast pumping speed in an ultra compact package.

▶ System Flexibility

Designed with flexibility in mind, this roots-style blower can be paired with a backing pump to optimize pumping efficiency.

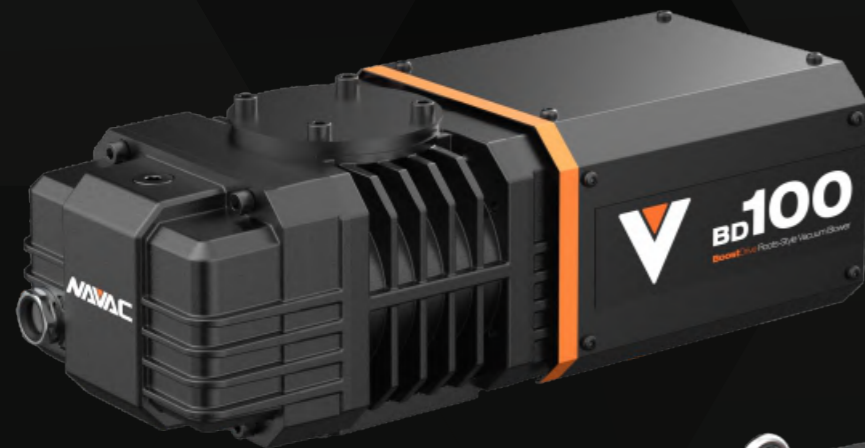

BD100

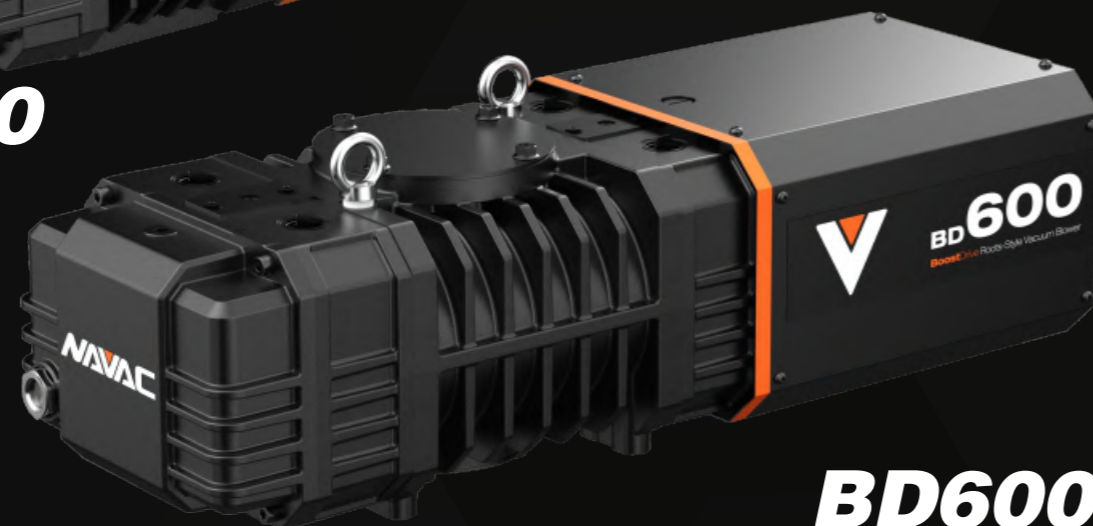

BD600

BoostDrive

High-Speed Roots-Style Vacuum Blower ▼

SPEC		BD100	BD600
Pumping Speed (60Hz)	m ³ /h (CFM)	190 (112)	720 (424)
Ultimate Pressure	mbar (Torr)	3.0x10 ⁻⁴ (2.3x10 ⁻⁴)	3.0x10 ⁻⁴ (2.3x10 ⁻⁴)
Max. Permissible Pressure Difference (60Hz)	mbar (Torr)	40 (30)	80 (60)
Backing Pump (Recommended)	/	DD48	UD100
Power Supply	/	200-230V/60Hz	460V/60Hz
Power Rating	kW	0.37	1.5
Oil Viscosity	/	100	100
Inlet	mm	VG 50	DN 100
Outlet	mm	VF 50	DN 63
Noise	dB(A)	62	63
Weight	lbs	50.7	218
Dimensions (L*W*H)	in	19.4x8.3x6.3	30.7x11.2x10

Dimensions

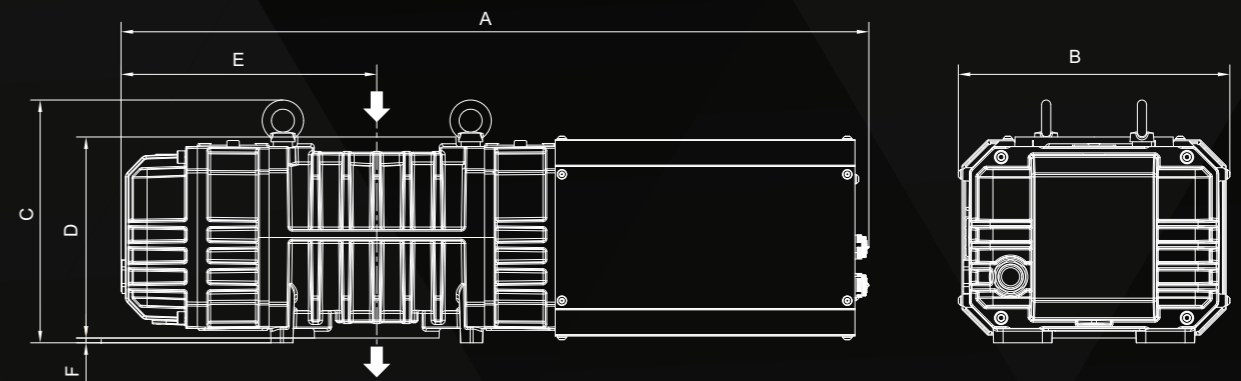

Unit: inch

Model	A	B	C	D	E	F	Inlet	Outlet
BD100	19.4	8.3	6.3	/	6.5	/	VG 50	VF 50
BD600	30.7	11.2	10	8.3	10.5	0.2	DN 100	DN 63

Genuine OEM Parts

▼ Vacuum Solutions for Every Industrial Challenge

Unrivaled Technical Support

NAVAC's commitment to your success goes beyond delivering exceptional products. With our dedicated technical support team, we're ready to assist you with any inquiries or challenges you may encounter. We prioritize your success while helping you navigate all your vacuum needs.

Commitment to Excellence

Excellence is not just a goal at NAVAC, it's a standard we live by. From quality of our products to the reliability of our solutions and the support we provide, we strive for nothing less than excellence. Our dedication to continuous improvements ensures that NAVAC remains synonymous with top-tier industrial vacuum pumps.

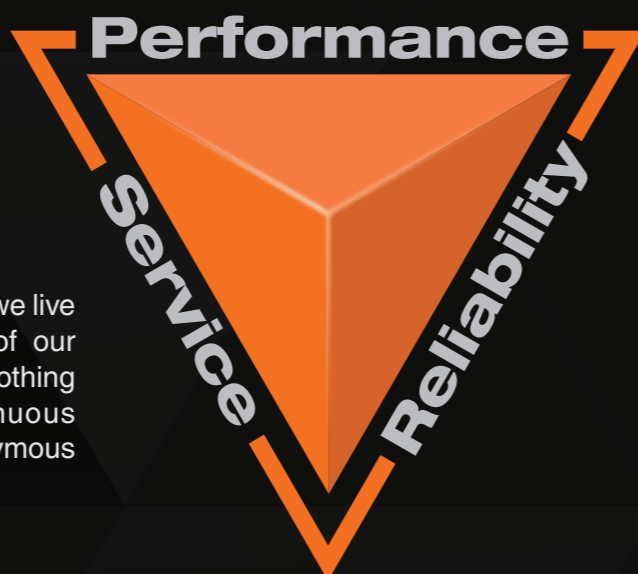

Contact Us

For information on authorized service partners, please visit our website.

1099 Wall Street W, Suite 179
Lyndhurst, NJ 07071

Tel/Fax: +1 877 MY-NAVAC

+1 877 696 2822

info@navacglobal.com

www.NavacVacuum.com



Spare Parts

Designed & Built to Withstand The Toughest Industrial Processes ▼



<p>Oil Mist Filter</p>	<p>Connectors and Fittings</p>	<p>KF Model Air Inlet</p>	<p>O-Ring</p>
<p>Clamp</p>	<p>Centering Ring</p>	<p>Filter</p>	<p>Flange</p>
<p>Adapter</p>	<p>Pump Oil</p>		

