



# **SOGEVAC SV 220 B/220 FP**

Oil-Sealed Rotary Vane Pump

**Operating instructions 301029767\_002\_C1**



Part Numbers  
12330220VXX

# Copyright notice

©Leybold GmbH. All rights reserved.

Published: 7/10/2023

# Trademark credit

Leybold and the Leybold logo are trademarks of Leybold GmbH, Bonner Strasse 498, D-50968 Cologne.

# Disclaimer

The content of this manual may change from time to time without notice. We accept no liability for any errors that may appear in this manual nor do we make any expressed or implied warranties regarding the content. As far as practical we have ensured that the products have been designed and constructed to be safe and without risks when properly installed and used in accordance with their operating instructions.

We accept no liability for loss of profit, loss of market or any other indirect or consequential loss whatsoever.

Product warranty and limit of liability are dealt with in our standard terms and conditions of sale or negotiated contract under which this document is supplied.

You must use this product as described in this manual. Read the manual before you install, operate, or maintain the product.

# Contents

<b>1 Safety and compliance.</b>	<b>7</b>
1.1 Definition of Warnings and Cautions.	7
1.2 Trained personnel	7
1.3 Safety symbols.	8
<b>2 Important safety information.</b>	<b>9</b>
<b>3 Description.</b>	<b>10</b>
3.1 Design and function.	10
3.2 Range of use.	11
<b>4 Technical data.</b>	<b>12</b>
4.1 Dimension drawing.	13
4.2 Performance graphs.	13
4.3 Ordering data.	14
4.4 Conversion factor.	15
4.5 Water cooling.	15
4.6 Connection fittings.	16
<b>5 Transportation.</b>	<b>18</b>
<b>6 Installation.</b>	<b>19</b>
6.1 Connection to system.	19
6.1.1 Intake side.	19
6.1.2 Exhaust side.	20
6.2 Electrical connections.	21
<b>7 Operation.</b>	<b>22</b>
7.1 Pumping of non-condensable gases.	22
7.2 Pumping of condensable gases and vapour through gas ballast.	23
7.3 Working in cycles in and out.	23
7.4 Start-up.	23
7.5 Shutdown.	24
7.6 Pump ultimate pressure.	24
<b>8 Maintenance.</b>	<b>25</b>
8.1 Maintenance schedule.	25
8.2 Lubricants and grease.	27
8.3 Check the oil.	27

# Contents

8.3.1 Oil level. . . . .	27
8.3.2 Oil condition. . . . .	27
8.4 Oil change and replace the oil filter. . . . .	28
8.5 Clean the dirt trap. . . . .	28
8.6 Check the anti-suck back valve. . . . .	29
8.7 Clean the gas ballast intake filter. . . . .	29
8.8 Exchange of electrical motor. . . . .	29
8.9 Clean the radiator. . . . .	30
8.10 Exhaust filter exchange. . . . .	30
8.11 Clean the water/oil heat exchanger. . . . .	30
<b>9 Fault finding. . . . .</b>	<b>32</b>
<b>10 Storage. . . . .</b>	<b>36</b>
<b>11 Disposal. . . . .</b>	<b>37</b>
<b>12 Service. . . . .</b>	<b>38</b>
12.1 Return the equipment or components for service . . . . .	38
<b>13 Accessories. . . . .</b>	<b>39</b>
<b>14 Legal declarations. . . . .</b>	<b>40</b>

# List of Figures

Figure 1. SV 220 B/220 FP.....	11
Figure 2. Dimension drawing - SV 220 B/220 FP.....	13
Figure 3. Flow curve 50 Hz - SV 220 B/220 FP.....	13
Figure 4. Flow curve 60 Hz - SV 220 B/220 FP.....	14
Figure 5. Water cooling connections.....	15
Figure 6. Water cooling.....	16
Figure 7. Connection fittings - SV 220 B/220 FP.....	16
Figure 8. Radiator.....	30

# List of Tables

Table 1: Technical data - SV 220 B/220 FP.....	12
Table 2: H2O capacity - SV 220 B/220 FP.....	12
Table 3: Ordering data - SV 220 B/220 FP.....	14
Table 4: Service interval.....	26
Table 5: Lubricants.....	27
Table 6: Fault finding.....	32
Table 7: Consumables.....	39
Table 8: Tools required.....	39

# Safety and compliance

## 1 Safety and compliance

For safe operation from the start, read these instructions carefully before you install or commission the equipment and keep them safe for future use. Read all the safety instructions in this section and the rest of this manual carefully and make sure that you obey these instructions.

The instruction manual is an important safety document that we often deliver digitally. It is your responsibility to keep the instruction manual available and visible while working with the equipment. Please download the digital version of the instruction manual for use on your device or print it if a device will not be available.

### 1.1 Definition of Warnings and Cautions

Important safety information is highlighted as warning and caution instructions which are defined as follows. Different symbols are used according to the type of hazard.

---

#### **WARNING:**

**If you do not obey a warning, there is a risk of injury or death.**

---

#### **CAUTION:**

**If you do not obey a caution, there is a risk of minor injury, damage to equipment, related equipment or process.**

---

#### **NOTICE:**

**Information about properties or instructions for an action which, if ignored, will cause damage to the equipment.**

---

We reserve the right to change the design and the stated data. The illustrations are not binding.

### 1.2 Trained personnel

For the operation of this equipment “trained personnel” are:

- skilled workers with knowledge in the fields of mechanics, electrical engineering, pollution abatement and vacuum technology and
- personnel specially trained for the operation of vacuum pumps

# Safety and compliance

## 1.3 Safety symbols

The safety symbols on the products show the areas where care and attention is necessary.

The safety symbols that we use on the product or in the product documentation have the following meanings:

	<b>Warning/Caution</b> Risk of injury and/or damage to equipment. An appropriate safety instruction must be followed or a potential hazard exists.
	<b>Warning - Hot surfaces</b> Risk of injury. Identifies a surface capable of inflicting burns through contact.
	<b>Warning - Risk of explosion</b> Risk of injury or damage to equipment. Identifies a situation that could result in an explosion.
	Warning - Trip hazard There is a risk of slipping, tripping or falling as a result of spilled liquids, trailing cords and pipes or other low-lying objects.
	Warning - Dangerous voltage Identifies possible hazards from dangerous voltages.

# Important safety information

## 2 Important safety information



### **WARNING: HAZARDOUS VOLTAGES**

Risk of electric shock. Disconnect the unit from the power supply before starting any work. Take appropriate precautions to make sure that the pump will not start.

---



### **WARNING: HAZARDOUS GASES**

Risk of injury or damage to the equipment. If the pump has pumped hazardous gases, it will be absolutely necessary to determine the nature of the hazard involved and take the appropriate safety precautions. Observe all safety regulations. Take adequate safety precautions prior to opening the intake or exhaust port.

---



### **WARNING: TRANSPORTATION SAFETY**

Risk of injury or damage to the equipment. The pump must be packaged in such a way that it will not be damaged during shipping, and so that no harmful substances can escape from the package.

---



### **CAUTION: OPERATION SAFETY**

Risk of damage to the equipment. Do not open the pump to condensable vapours until it has reached the operating temperature. Pumping process gas with a cold pump results in vapours condensing in the oil.

---



### **CAUTION: INTERNAL CONDENSATION**

Risk of corrosion. When vapour are pumped, do not switch off the pump immediately after the completion of the process because the condensate dissolved in the pump oil may cause changes or corrosion. To prevent this, continue to operate the pump with open gas ballast valve and closed intake port until the oil is free of condensate. We recommend you to operate the pump in this mode for at least 30 minutes after completion of the process.

---

For processes with a high proportion of condensable vapours, the intake line must be opened slowly only after the pump has reached the operating temperature.

One sign of condensation of vapours in the pump is a rise of the oil level during the operation of the pump. During pumping, vapour may dissolve in the oil.

In cyclic operation, do not switch off the pump between the cycles and continue to run with the gas ballast valve open and intake port closed (if possible, through a valve). The power consumption is minimal when the pump is operating at ultimate pressure.

If all vapour are pumped off from a process (for example, during drying), the gas ballast valve can be closed to improve the ultimate pressure.

# Description

## 3 Description

### 3.1 Design and function

The pumps are single-stage, oil-sealed rotary vane vacuum pumps. The anti-suckback valve, gas ballast valve (optional), exhaust filter, oil return circuit and oil cooling oil are integrated functional elements. The pumps are driven by a directly flanged motor.

The rotor is eccentrically installed in the pump cylinder (stator) and has three vanes which divide the pump chamber into several compartments. The volume of these chambers varies with the rotation of the rotor.

As the rotor rotates, the intake portion of the pumping chamber expands and sucks gas through the intake port. The gas passes through the dirt trap and open anti-suckback valve and enters the pump chamber. As the rotor rotates, the vane separates part of the pump chamber from the intake port. This part of the pump chamber is reduced and the gas is compressed. Slightly above atmospheric pressure the gas is expelled from the chamber through the exhaust valve.

The oil injected into the pump chamber seal, lubricate and cool the pump. The oil and the compressed gas is coarsely trapped in the oil case by deflection. Fine filtering of the oil in the exhaust filter element is done, this reduces the proportion of oil in the exhaust gas below the visibility threshold (over 99.9% entrapment rate).

Oil trapped in the exhaust filters is returned to the inlet chamber through the oil return line. To prevent the gas flow at the atmospheric pressure from the oil reservoir into the intake port, the oil return line is controlled by a float valve.

The oil cycle is maintained by the pressure difference existing between the oil case (pressure above or equal to atmospheric pressure) and the intake port (pressure below atmospheric pressure).

A fan running on the pump shaft generates the necessary cooling air. The oil cools down through a radiator.

Water cooled pumps with an oil-water heat exchanger are also available (as specific variants).

By opening the gas ballast valve, a controlled amount of air (gas ballast) enters into the pump chamber. This gas ballast prevents condensation (up to the limit of water vapour tolerance specified in the [Technical data](#) on page 12) when pumping the condensable gases or vapour.

There are different types of gas ballast :

- Standard gas ballast (7 m<sup>3</sup>/h). This gas ballast corresponds to the most important part of applications.
- Large gas ballast (18 m<sup>3</sup>/h) as a variant or accessory is intended for the applications where more vapours of condensable gases could come into the pump.
- Gas ballast with electromagnetic valve (6 m<sup>3</sup>/h). This kit is intended for being mounted on pumps on which the gas ballast can be driven by an electromagnetic valve applied at 24 V d.c. Refer to [Pumping of condensable gases and vapour through gas ballast](#) on page 23.

The gas ballast flows are indicative and valid at ultimate pressure.

# Description

Anti-suckback valve prevents the unintentional venting of the vacuum chamber and an oil suckback when shutting down the pump. In applications where an oil suckback must be avoided by all means, it is recommended to install a safety inlet valve.

The pump is supplied with drive motor in ready-to-use condition. It is supplied with filled in oil.

Specific variants of the pump are delivered with different oils. The oil type is indicated on the pump. Do not use another oil than specified, no warranty claims would be accepted if use with different oil. The connection ports are blanked off by plastic protective caps. Take these caps away before turning on the pump.

Figure 1. SV 220 B/220 FP

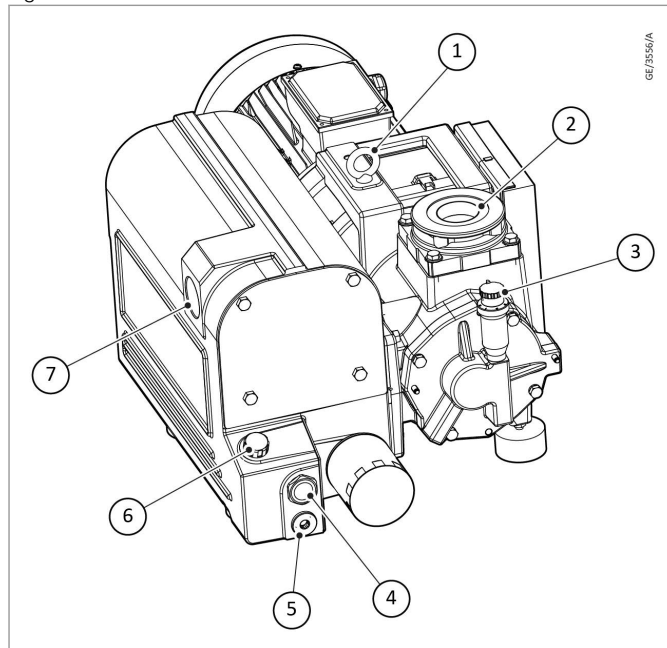

- |                 |                    |
|-----------------|--------------------|
| 1. Lifting lug  | 2. Inlet port      |
| 3. Gas ballast  | 4. Oil sight glass |
| 5. Oil drain    | 6. Oil filling     |
| 7. Exhaust port |                    |

## 3.2 Range of use

The pump is designed for pumping the inert gases in the range of vacuum, between atmospheric pressure and ultimate pressure of the pump.

The pump are not designed for pumping of aggressive, corrosive, flammable or explosive gases. In the presence of aggressive, flammable, corrosive or explosive gases, contact us.

The pumps are not designed for working in flammable or explosive environment.

The pumps are not suitable for pumping liquids or media which contain dust. Protective measures must be introduced.

# Technical data

## 4 Technical data

**Table 1 Technical data - SV 220 B/220 FP**

Parameter	50 Hz	60 Hz
Nominal speed *	200 m <sup>3</sup> .h <sup>-1</sup>	240 m <sup>3</sup> .h <sup>-1</sup>
Pumping speed *	179 m <sup>3</sup> .h <sup>-1</sup>	214 m <sup>3</sup> .h <sup>-1</sup>
Noise level **	69 dB(A)	73 dB(A)
Net weight (with oil filling)	180 kg	
Oil volume	7.5 L (8 qt)	
Intake connection	G2" BSP for NPT use adapter part number 8092301921	
Exhaust connection		
Ambient temperature	12 to 40 °C	
Ultimate total pressure without gas ballast *	≤ 0.08 mbar	

\* To DIN 28400 and following numbers, valid for mineral and some synthetic oils.

\*\* Operated at the ultimate pressure without gas ballast, free-field measurement at a distance of 1 m.

**Table 2 H<sub>2</sub>O capacity - SV 220 B/220 FP**

Gas ballast	Part number	Flow	Ultimate pressure	H <sub>2</sub> O tolerance 50 Hz	H <sub>2</sub> O tolerance 60 Hz
		Nm <sup>3</sup> /h	mbar	mbar (l/h)	mbar (l/h)
Manual, small flow	GK6703134	2	≤ 0.2	-	-
Manual, medium flow		4	≤ 0.4	-	-
Manual, standard flow		7	≤ 0.7	10 (1.7)	10 (2)
EM 24 V d.c.	GK6704190	6	≤ 0.7	10 (1.7)	10 (2)
Big	9600GGB	18	≤ 4.0	35 (4.2)	40 (6.3)

# Technical data

## 4.1 Dimension drawing

Figure 2. Dimension drawing - SV 220 B/220 FP

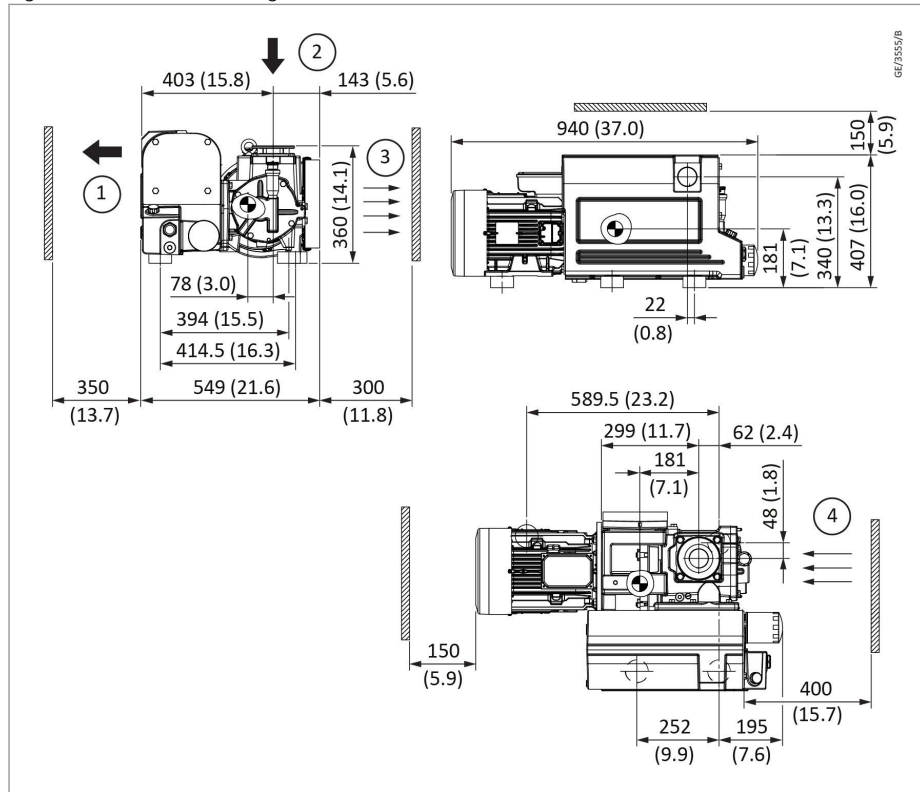

- |                     |                     |
|---------------------|---------------------|
| 1. Exhaust port     | 2. Inlet port       |
| 3. Cooling air pump | 4. Cooling air pump |

## 4.2 Performance graphs

Figure 3. Flow curve 50 Hz - SV 220 B/220 FP

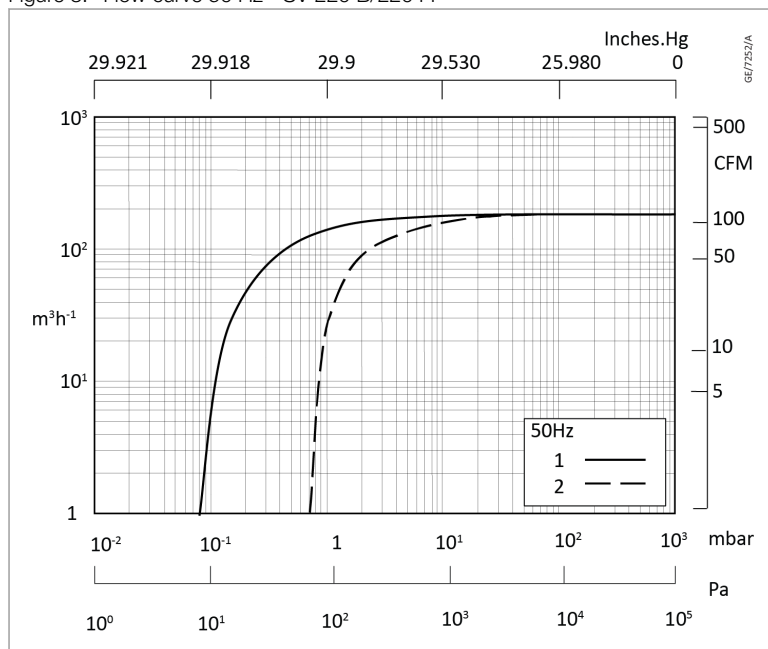

- |                        |                              |
|------------------------|------------------------------|
| 1. Without gas ballast | 2. With standard gas ballast |
|------------------------|------------------------------|



# Technical data

## 4.4 Conversion factor

These values are valid for the standard variants and with the use of the recommended company oils.

	<b>mbar (millibar)</b>	<b>torr</b>	<b>inches Hg vacuum</b>
1 lb = 0.453 kg	1013	760	0
1 qt = 0.946 l	400	300	18.12
1 hp = 0.735 kW	133	100	25.98
1 inch = 25.4 mm	4	3	29.80
1 r.p.m. = 1 min <sup>-1</sup>	1	0.75	29.89

1 atm (atmosphere) = 1013 mbar

1 Pa (pascal) = 0.01 mbar = 10<sup>-2</sup> mbar

1 bar = 1000 mbar

1 torr = 1.33 mbar

	<b>m<sup>3</sup>. h<sup>-1</sup></b>	<b>l.s<sup>-1</sup></b>	<b>cfm</b>
m <sup>3</sup> . h <sup>-1</sup> = m <sup>3</sup> /h <sup>1</sup>	1	0.278	0.589
l.s <sup>-1</sup> = l/s	3.60	1	2.12
cfm (cubic feet per minute)	1.699	0.472	1

For example: 1 m<sup>3</sup>.h<sup>-1</sup> = 0.589 cfm

## 4.5 Water cooling

Pressure of water network	2 bar minimum and 8 bar maximum
Minimum water supply	200 l/h for water temperature of 15 °C
Maximum water temperature	30 °C

Figure 5. Water cooling connections

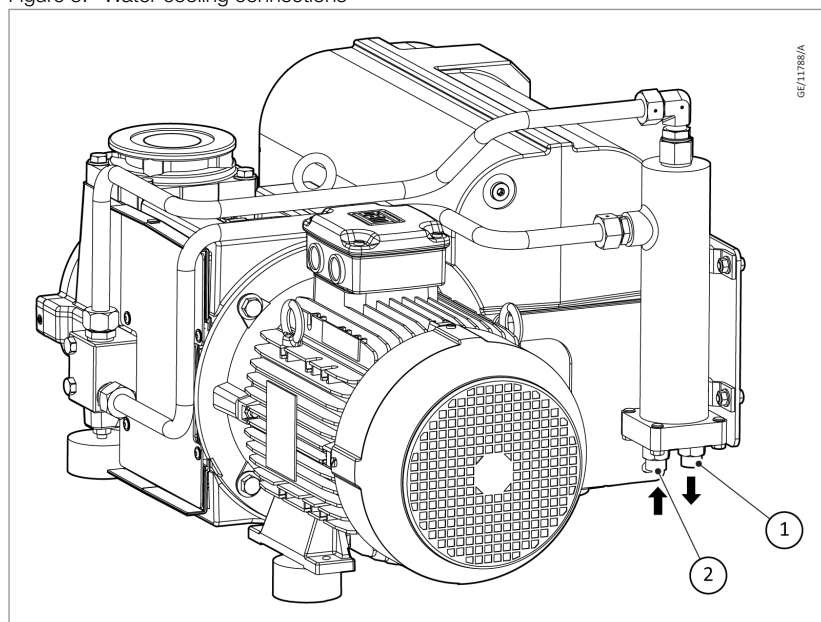

1. Water outlet - G3/8 male connection

2. Water inlet - G3/8 male connection

# Technical data

Figure 6. Water cooling

WATER QUALITY	0°	4°	8°	12°	20°
TH(°F)	CORROSION (WATER TOO SOFT)	SERVICE AREA	INCRUSTING WATER (DEPOSIT OF SCALE)		
CARBONAT CONTENT	0	30	90	160	300
	CORROSION (AGRESSIVE WATER)	SERVICE AREA	INCRUSTING WATER	VERY INCRUSTING WATER	
PH	CORROSION (AGGRESSIVE WATER)	5	7.5	INCRUSTING WATER	

## 4.6 Connection fittings

Figure 7. Connection fittings - SV 220 B/220 FP

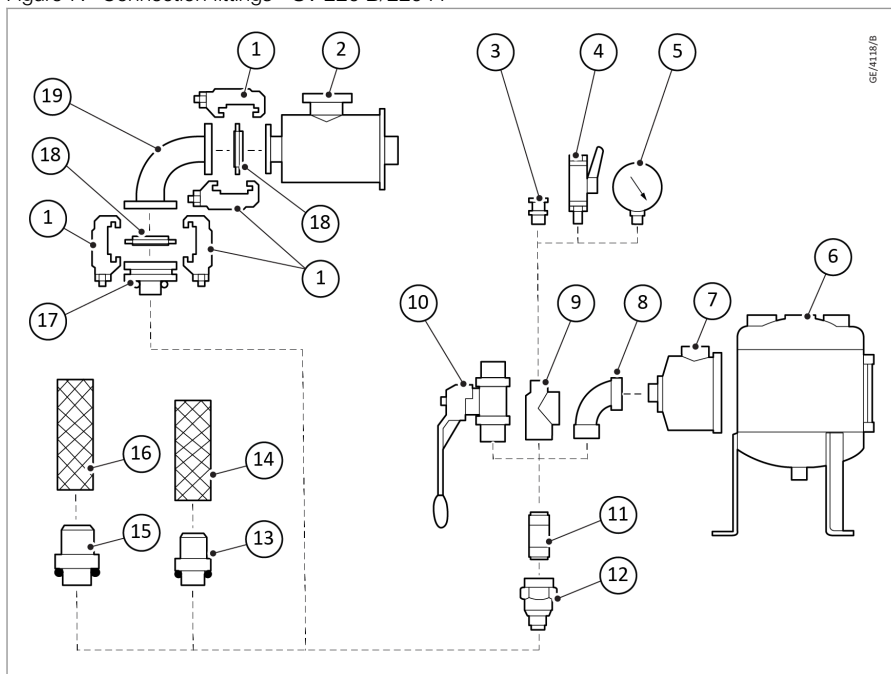

Item	Description	Part number
1	Set of clamping screws DN ISO-K (4 pieces)	26701
2	Dust filter with paper cartridge, DN 63 ISO-K (Spare cartridge 71213293)	95168
	Dust filter with activated charcoal cartridge, DN 63 ISO-K (Spare cartridge 71213314)	71127125
	Dust filter with metal cartridge, DN 63 ISO-K (Spare cartridge 71213334)	71127126
	Dust filter with polyester filter cartridge, DN 63 ISO-K (Spare cartridge 71261318)	71127127
3	Threaded ISO-KF small-flange adaptor with NBR-O-Ring, G 1/2" M - DN 16 ISO-KF, Aluminium anodized	71118120
4	Ball valve, G 1/2" M/F, Brass nickelled/Aluminium	71130113
5	Bourdon vacuum gauge, G 1/2" M	95192
6	Condensate trap, G 2" - 2" - 1/2" F/F/F†	95144

## Technical data

Item	Description	Part number
7	Dust filter with paper cartridge, G 2" M/F, (Spare cartridge 71213293)*	95165
	Dust filter with activated charcoal cartridge, G 2" M/F, (Spare cartridge 71213314)*	71127122
	Dust filter with metal cartridge, G 2" M/F, (Spare cartridge 71213334)*	71127123
	Dust filter with polyester filter cartridge, G 2" M/F, (Spare cartridge 71261318)*	71127124
8	Elbow 90°, G 2" F/F, Grey cast iron	71118215V
9	Tee reducer, G 2" – 2" – 1/2" F/F/F, Grey cast iron	71118265
10	Ball valve, G 2" F/F, Brass nickelled	71130107
11	Double nipple, G 2" M/M – 150 mm, Steel	71118035V
12	Screw coupling with NBR-O-Ring, G 2" M/F, Aluminium anodized	71118025V
13	Hose connection with NBR-O-Ring, M10 x 24, Steel zinc coated	71118015
14	PVC tubing, ø 50 mm, 1 m long, PVC	71118325
15	Hose connection with NBR-O-Ring, G 2" M - DN 60 mm, Aluminium anodized	71118016
16	PVC tubing, ø 60 mm, 1 m long, PVC	71118326
17	Threaded flange adaptor with NBR-O-Ring, G 2" M – DN 63 ISO-K, Steel zinc coated	71118126
18	Centering ring with outer ring with NBR-O-Ring, DN 63 ISO-K, Aluminium/CR	26805
19	Elbow 90°, DN 63 ISO-K, Stainless steel	88725

\* Set of gaskets for Dust filter F200-300 NBR (Buna N) - 71410850

† Drain valve - 71130113

# Transportation

## 5 Transportation

---



### **WARNING: TRIP HAZARD**

Risk of injury. Oil can get leak from the pump and can cause slippage on the floor. Check the pump for presence of oil leak.

---



### **CAUTION: TOPPLE HAZARD**

Pumps which have been filled with operating agent must only be moved in the upright position (horizontally). The angle of inclination should not be more than 10°, otherwise oil can leak. Avoid any other orientations during transportation.

Only use the lifting lugs which are provided on the pump to lift the pump with the specified lifting devices.

---

## 6 Installation

Set the pump on any flat and horizontal surface. There are metric threaded M10 holes for securing the pump located below the pump. In case of close coupled roots combinations, the holes are M14 threaded.

Do not tilt the pump to avoid error in reading of the oil level. Pump must be horizontal  $\pm 1$  degree.

Make sure that there is adequate cooling of the pump, leave sufficient space at the air intake and the exhaust points for cooling and to give access for maintenance. Make sure to keep the air intake clear for the motor.

Do not install the standard pump in and explosion hazard areas. Contact us, when you are planning such an application. Before you install the pump, disconnect it from the electrical power supply and prevent the pump from running up accidentally.

Observe all safety regulations.

### 6.1 Connection to system

#### 6.1.1 Intake side

The pump has an internally-threaded intake flange. With the suitable connecting elements (refer to [Connection fittings](#) on page 16), the pump can be connected to the vacuum system. The cross-section of the intake line must be a minimum of as same as the intake port. If the intake line cross-section is too narrow, it reduces the pumping speed. We recommend to apply LOCTITE or TEFLON tape to the screwed unions to make them vacuum-tight (especially if gases are dangerous).

- When you connect the pump to the inlet line, make sure that inlet line do not have any tension. Use flex lines or pipe unions in your inlet and exhaust lines so that they can be easily removed for pump maintenance.
- The maximum pressure at the inlet should not exceed atmospheric pressure (about 1013 mbar). Do not operate the pump in the presence of over pressures at the intake.
- Type of materials used for pipes must be compatible with pumped gases. It is the same for the tightness.

If the process gas contains dust or small particles, install a dust filter in addition to the dust trap supplied (refer to [Connection fittings](#) on page 16). We recommend you to install the dust filter horizontally using the T-piece or the elbow, to make sure that when you remove the filter, no particle falls into the intake port.

There are four type of cartridge for the optional inlet filters.

- The metal cartridge prevents solid particles such as paper or plastics from entering the pump.
- The paper and polyester cartridges remove small particles such as dust and powder (upto one micron thickness).
- The activated carbon cartridge absorbs chemical vapour of acids, solvents, etc.

 **Note:**

If the carbon cartridge was stored in a damp place, bake it for 2 hours at 212 °F (100 °C) before use.

# Installation

Install condensate traps or condensers on the intake side (refer to [Connection fittings](#) on page 16), when you pump vapour.

Make sure that the inlet line is tightly sealed before you pump the dangerous gases.

No particles or liquids must enter in the pump.

## 6.1.2 Exhaust side



### **WARNING: EXPLOSION HAZARD**

**Risk of injury. Excessive backpressure can result in leakage of hazardous process gases out of the pump. If you are purging the oil casing with inert gas, limit the inert-gas flow. Contact us for recommendations.**



### **WARNING: EXPLOSION HAZARD**

**Risk of injury. The maximum exhaust pressure must not exceed 1.15 bar (absolute). Prevent the blockage in the exhaust line. Exhaust filter, accessories and the tubing must be rated according to the maximum pumping speed (maximum throughput) of the pumps.**

---

The pumps have integrated exhaust filters which at a high gas throughput, traps all the oil mist from the exhaust gases. If the exhaust filters are clogged, pressure relief valve opens and the filters are bypassed. As a result, the proportion of the oil in the exhaust gas as well as the pump's oil consumption rises. Install new exhaust filters when the exhaust filters are clogged (refer to [Exhaust filter exchange](#) on page 30).

It is your responsibility to do maintenance to avoid exceeding of the limits authorised by the regulations.

Check that whether an exhaust line is necessary and/or prescribed. Volatile substances can pass through the filter. Depending on the processed gas, we recommend to connect an exhaust line, this is necessary when the exhaust gases are dangerous.

Observe the safety precautions that apply to your application and process gases. The pump's exhaust port also has an internal thread. A hose can be connected through a suitable screw-in nipple (refer to [Connection fittings](#) on page 16 and [Figure: Connection fittings - SV 220 B/220 FP](#) on page 16).

The cross-section of the exhaust line should be at least the same as the pump's exhaust port. If the exhaust line cross-section is too narrow, overpressure can occur in the pump.

Before installing the exhaust line, remove the exhaust-flange plate and make sure that the exhaust demister(s) are secured tightly in place. Exhaust demisters may get loosen during shipping and installation. A loose demister results in exhaust smoke during start-up and operation.

Install the exhaust line with a downward slope to prevent condensate from flowing back into the pump. If this is not possible, we strongly recommend you to install a condensate trap (refer to [Table: Accessories](#)). If several pumps are connected to one exhaust line, make sure that an adequate cross-section of the exhaust line is present and a non-return valve at the exhaust of each pump is installed.

Do not operate the pump with a blocked or restricted exhaust line. Before start-up make sure that any blinds or similar shut-off devices in the exhaust line on the pressure side are opened and that the exhaust line is not obstructed. Such restrictions reduce the pumping speed, increase the temperature and could overload the motor or cause a dangerous overpressure in the pump. Excessive pressure in the pump could damage the seals, blow out the sight glass or destroy the pump housing. When pumping dangerous gases, exhaust line must be tight.

## 6.2 Electrical connections

(See the motor nameplate)

Make sure that the power is off before wiring the motor or changing the wiring of the pump. Electrical connections must be done by a qualified electrician in accordance with the applicable safety regulations.

Wire the motor for the correct supply voltage through connections in the junction box, see the wiring diagram on the motor name plate. For proper connection, a suitable motor protection switch of at least class 10 must be used. Set the switch in accordance with the rating on the motor name plate.

After connecting the motor or every time you alter the wiring, check the direction of rotation of the motor. Observe the direction arrow on the motor hood. During the check, the intake port must be open. If the direction of rotation is wrong, oil may be ejected out of the intake port. The vacuum system may be pressurised. Do not use the motor fan for checking the rotation direction. The motor fan rotates too fast during operation and when slows during shutdown, it reserves its direction of rotation.

Turn off the power supply and interchange two phases of the connection, if you need to correct the direction of rotation.

We recommend you to check the direction of rotation with a phase-sequence indicator.

Prolonged running of the motor in the wrong direction of rotation will damage the pump.

A thermal overload switch is available as an accessory. It cuts out the pump if a specific temperature is exceeded and/or triggers a warning signal.

If any security switch or electrical defect cuts out the pump, restarting the pump is only possible by hand-action. See wiring diagram on motor name plate or junction box depending on the motor type.

# Operation

## 7 Operation



### **WARNING: HOT SURFACE**

**Risk of burns. Do not touch the pump when it is in operation. Few surfaces of the pump can reach a temperature of upto 80 °C (176 °F). Check for warning labels on the pump.**

---

The pumps can pump gases and vapour, provided that the gas ballast valve is installed, open and the pump has reached its operating temperature.

#### **Note:**

Contact us for important safety instructions before pumping greater than atmospheric concentrations of oxygen or other highly reactive gases. The pump must be degreased, modified, and special inert oil must be used for pumping oxygen. Also ATEX variants are available for pumping explosive gases.

The motor manufacturer guarantees a maximum of 6 starts per hour. To avoid exceeding 6 starts per hour, run the pump continuously and regulate the vacuum in your system with a pilot valve.

The connection ports are blanked off by plastic protective caps. Remove these caps before you turn on the pump.

It is essential to observe the following instructions step by step to make sure a safe start-up. Start-up may only be conducted by trained specialists.

Do not run the pump when it is dry. The ambient temperature should be between 12 °C (55 °F) and 40 °C (104 °F) depending on the oil type. By modifying the pump or changing the oil type, the pump can be run at a lower ambient temperature, contact us for the information about this.

If the pump has been shelved for more than one year, standard maintenance must be run (refer to [Maintenance](#) on page 25). The oil must be changed before the pump is put into service again (refer to [Oil change and replace the oil filter](#) on page 28). We recommend that you contact us for service.

Do not open the pump to condensable vapour until it has warmed to operating temperature, pumping process gas with a cold pump results in vapour condensing in the oil.

For processes with a high proportion of condensable vapour, slowly open the intake line, after reaching the operating temperature to prevent excessive quantities of vapour entering the pump.

One sign of condensation of vapour in the pump is a rise in the oil level during operation of the pump.

During pumping, vapour may dissolve in the oil. This changes the oil properties and causes a risk of corrosion in the pump. Therefore, do not switch off the pump immediately after completion of the process. Instead, allow the pump to continue operating with the gas ballast valve open and the intake line closed until the oil is free of condensed vapour. We strongly recommend operating the pump in this mode for about 30 minutes after completion of the process.

### **7.1 Pumping of non-condensable gases**

If the process contains mainly permanent gases, the pumps can be operated without gas ballast, provided that the saturation vapour pressure at operating temperature is not exceeded during compression.

If you do not know the composition of the gases to be pumped and if you cannot remove the possibility of condensation, run the pump with gas ballast valve open in as given in [Pumping of condensable gases and vapour through gas ballast](#) on page 23.

## 7.2 Pumping of condensable gases and vapour through gas ballast

The pumps with gas ballast valves are delivered with the gas ballast valve open.

The pumps can be equipped with different gas ballast types refer to [Design and function](#) on page 10.

With the gas ballast valve open and at operating temperature, the pumps can pump pure water vapour up to the water vapour tolerance indicated in the [Technical data](#) on page 12. The pump's water vapour tolerance can be increased by raising the operating temperature.

The running noise of the pump is slightly louder when the gas ballast valve is open. Before you open the pump for vapour, make sure that the gas ballast valve is open and that the pump has been warmed up for about 30 minutes with closed intake line.

If the gas ballast is connected to an inert gas supply, the pressure of the latter must not be above 1 bar abs.

## 7.3 Working in cycles in and out

Limit starting of the pump up to 5 or 6 times per hour. If the process need it, use a pneumatic or electromagnetic piloted valve and to let the pump run continuously.

## 7.4 Start-up



### **WARNING: VACUUM HAZARD**

**Risk of injury. Do not expose part of the body to the vacuum. Do not lay the hand on the intake to check vacuum. Do not operate the pump with an open and accessible inlet. Exposure of a part of the body to the vacuum result in a rush of blood in the exposed part. Vacuum connections, oil filling and oil draining openings must not be opened during operation of the pump.**

---

Oil for the first filling is supplied with the pump.

- Before switching on, always make sure that the pump contains sufficient oil.
- The normal oil level is in the middle of sight glass.
- If oil has to be added, unscrew the oil-fill plug, add oil and screw the plug firmly back.

The pump is designed for fail-safe start-up at temperature over 12 °C with mineral oil.

To prevent overloading the motor:

- Do not start the pump more than six times within one hour.
- If frequent starts are needed, the pump must run continuously and be linked to the vacuum vessel by a valve. In that case, regulation will be made by the valve and not by start/stop of the pump.

With the valve closed, the pump consumes less energy.

# Operation

- Before you start the pump, make sure that the pump and the fitted accessories meet the requirements of your application and that safe operation can be guaranteed.
- The safety regulations which apply to the specific application in each case must be observed. This applies to installation, operation and maintenance (service) as well as waste disposal and transportation. Contact us for details.

Depending on the process involved, dangerous substances may escape from the pump and oil. Take the appropriate precautions.

Observe the safety regulations.

## 7.5 Shutdown

Under normal circumstances, switch off the pump. The intake port of the pump contains an anti-suckback valve, which closes the intake port when the pump is shut down, this maintains the vacuum in the connected system and prevents oil from being sucked back into the system. The valve's functioning is not impaired by gas ballasting, but its cleanliness must be taken care.

When pumping condensable media, let the pump continue to operate with the gas ballast valve open and the intake line closed before switching off (refer to [Pumping of condensable gases and vapour through gas ballast](#) on page 23).

### Note:

Special preservation or slushing oils are not necessary.

When the pump has been switched off due to over-heating, initiated by the motor or its protection, the pump must be cooled down to the ambient temperature and must only be switched on again manually after correcting the cause for over-heating.

To prevent the pump from running up unexpectedly after a main power failure, integrate the pump into the control system in such a way that the pump can only be started by manually operated switch. This applies also to emergency cut-off switches.

In case of switching processes in connection with a pump which has warmed up under operating conditions, the pump must not be directly switched on again.

## 7.6 Pump ultimate pressure

If the system cannot reach the pressures specified in the [Technical data](#) on page 12, measure the ultimate pressure with a small vacuum tank at the pump's intake port after you disconnect the pump from the system.

Correct measurements can only be obtained with calibrated instruments.

Upon initial start-up, after long idle periods or after an oil change, it takes some time until the pump reaches the specified ultimate pressure. The pump has to attain its operating temperature and the pump oil has to be degassed. We recommend operating the pump initially with the gas ballast valve open.

The ultimate pressure depends on the pump temperature and the pump oil used. The best ultimate pressure can be obtained at a low pump temperature and by using the recommended oil types.

## 8 Maintenance

Disconnect the power before you disassemble the pump. Make sure that the pump cannot be accidentally started.

If the pump has pumped hazardous gases it will be necessary to determine the nature of the hazard involved and take the appropriate safety precautions.

Observe the safety regulations.

### 8.1 Maintenance schedule

Do not install used seals. Always use new seals. Use only genuine parts provided by us.

To simplify the maintenance work we recommend you to combine several jobs.

The frequencies stated in the maintenance schedule are approximate values for normal pump operation.

Unfavourable ambient conditions or aggressive media may require more frequent maintenance.

# Maintenance

**Table 4 Service interval**

Maintenance job	Frequency at normal (clean) application		Reference
	Synthetic oil	Mineral oil	
Check the oil level	Daily	Daily	Refer to <a href="#">Oil level</a> on page 27
Oil leaking checking	Monthly	Monthly	In case of leakage, contact our service
Check the oil condition	Every 2000 hours	Every 2000 hours	Refer to <a href="#">Oil condition</a> on page 27
Check exhaust filter condition	Every 2000 hours	Every 2000 hours	-
Subsequent oil changes	Every 6000 hours or 1 year	Every 4000 hours or 1 year	Refer to <a href="#">Oil change and replace the oil filter</a> on page 28
Replace the oil filter	At each oil change	At each oil change	Refer to <a href="#">Oil change and replace the oil filter</a> on page 28
Replace exhaust filter	At each oil change or if back pressure is over 0.4 bar	At each oil change or if back pressure is over 0.4 bar	Refer to <a href="#">Exhaust filter exchange</a> on page 30
Check the inlet filter cartridge, replace if necessary in case of an inlet filter being installed	Every 6000 hours or 1 year	Every 4000 hours or 1 year	-
Check and clean the dirt trap	Every 6000 hours or 1 year	Every 4000 hours or 1 year	Refer to <a href="#">Clean the dirt trap</a> on page 28
Check and clean the anti-suckback valve	Every 6000 hours or 1 year	Every 4000 hours or 1 year	Refer to Check the anti-suckback valve <a href="#">Check the anti-suck back valve</a> on page 29
Check and clean gas ballast valve	Every 6000 hours or 1 year	Every 4000 hours or 1 year	Refer to <a href="#">Clean the gas ballast intake filter</a> on page 29
Radiator cleaning	Depends on ambient conditions (minimum once a year)	Depends on ambient conditions (minimum once a year)	Refer to Radiator cleaning <a href="#">Clean the radiator</a> on page 30
Heat exchanger cleaning	Depends on ambient conditions (minimum once a year)	Depends on ambient conditions (minimum once a year)	Refer to <a href="#">Clean the water/oil heat exchanger</a> on page 30
Overhaul (replace all wear parts)	Every 30000 hours or 5 year	Every 24000 hours or 3 year	Contact us

## 8.2 Lubricants and grease

Unless otherwise specified on the pump, we recommend to run the pumps with Leybold oil provided by us which is approved by us and meets following requirements:

- Low vapour pressure, even at high temperatures
- Flat viscosity curve
- Minimum water content and absorption
- Good lubricating properties
- Resistant to ageing under mechanical strain.

If you use a non-approved oil, we cannot guarantee that our pumps will meet their operating specifications (ultimate pressure, pumping speed, noise, operating temperature, etc). However, the warranty is voided only if the non-approved oil adversely affects the operation or reliability of the pump.

When using other oil brands, employ non-detergent mineral oils of viscosity class ISO VG68 to ISO VG 100.

Use of other special-grade lubricants for specific applications is possible.

Please consult us.

Only use lubricants and grease which are approved by us.

**Table 5. Lubricants**

Pump oil	Part number
5 litres mineral oil	L13005
20 litres mineral oil	L13020
200 litres mineral oil	L13099
Ester oil	L21021
Food grade oil	L15020

## 8.3 Check the oil

### 8.3.1 Oil level

The pump oil level during operation must always be in the middle of the oil level glass. When necessary, switch off the pump and add the correct quantity of oil.

High oil consumption, indicates that exhaust filters are clogged. Change the exhaust filter change (refer to [Exhaust filter exchange](#) on page 30).

Check the oil level daily.

### 8.3.2 Oil condition

Normally the oil is clear and transparent. If gases or liquids dissolved in the oil result in deterioration of the ultimate pressure, the oil can be degassed by allowing the pump to run for about 30 minutes with the intake port closed and the gas ballast valve open.

The amount of oil required for an oil check must be drained through the oil-drain plug into a beaker or similar container with the pump switched off but at operating temperature.

# Maintenance

## 8.4 Oil change and replace the oil filter



### **WARNING: HOT SURFACE**

**Risk of burn. Do not touch the pump or surrounding surfaces during the operation as it could reach temperature higher than 80 °C (176 °F).**

---

1. Always change the oil when the pump is switched off but still at working temperature.
2. If there is a risk of the oil being polymerized by the connected process, change the oil immediately after operation of the pump.
3. Put a suitable oil drain container below the oil-drain plug, or better utilize a fluid extractor.
4. Unscrew the oil-drain plug with the allen key 12 or open the drain valve. Refer to [Table: Tools required](#).
5. Drain the used oil into the into appropriate waste container.
6. Depending on the process involved, dangerous substances may escape from the pump and oil. Take the appropriate precautions.
7. When the flow of oil slows down screw the oil-drain plug.
8. Switch on the pump for a maximum of 10 seconds and switch it off.
9. Remove the oil-drain plug or open the valve and drain the remaining oil.
10. Remove the old oil filter, turn right filter is machined with left thread.
11. Moisten the new oil filter gasket with oil and screw it in manually.
12. Check the plugs, O-ring and replace it with a new one if necessary.
13. Re-insert the oil-drain plug.
14. Unscrew the oil-fill plug.
15. Fill the pump with fresh oil up to the bottom edge of the oil-level glass, use only suitable oil.
16. Run the pump for a short time and check the oil level, top up if required.
17. Change the oil again.
18. Use suitable oil only (refer to [Table: Lubricants](#)).

## 8.5 Clean the dirt trap

A dirt trap for coarse particles is located in the intake flange of the pump. It should be kept clean to avoid reduction of the pumping speed.

1. Remove four screws with wrench 16. Refer to [Table: Tools required](#).
2. Remove the intake flange and gasket.
3. Remove the retaining ring and support piece from inside.
4. Remove the wire-mesh screen.
5. Clean the wire-mesh screen with a suitable solvent.
6. Re-assemble in the reverse sequence. We recommend you to replace the gasket by a new one.
7. Depending on the process involved, dangerous substances may escape from the pump and oil. Take the appropriate precautions.
8. Install new seal. Do not use old seal.

## 8.6 Check the anti-suck back valve

Keep the anti-suck back valve clean to make sure proper operation of the pump. If the pump is exposed to large amounts of dust or dirt, install a dust filter upstream (refer to [Connection fittings](#) on page 16).

Refer to Clean the dirt trap for details about pump inlet valve assembly.

1. Disconnect the intake line.
2. Remove four screws with wrench 16. Refer to [Table: Tools required](#).
3. Remove the intake flange and the gasket.
4. Remove the spring and the anti-suck back valve.
5. If the anti-suck back valve closes too soon, carefully compress the spring slightly.
6. The top edge of the valve should be 1-2 mm away from the bottom side of the intake port. Specific gauge is available see [Table: Tools required](#).
7. Depending on the process involved, dangerous substances may escape from the pump and oil. Take the appropriate precautions.
8. Install new seal. Do not use old seal.

## 8.7 Clean the gas ballast intake filter

On the big flow gas ballast, the inlet filter must be changed when the gas ballast flow decreases. Refer to [Accessories](#) on page 39 for part number.

## 8.8 Exchange of electrical motor

1. Disconnect the electrical power before you disassemble the pump. Make sure that the pump cannot be accidentally started (logout/tagout).
2. Remove the 4 hexagonal head screws to disassemble motor from coupling housing. For safety reason contact us, additional centering tools could be necessary.
3. Loosen the turbine locking screw with a wrench 10.
4. Remove the coupling of the motor shaft with an extractor puller.
5. Re-assemble in the reverse sequence.
6. Check the direction of motor rotation.

# Maintenance

## 8.9 Clean the radiator

Keep the air oil cooler and turbine clean to have an efficient cooling. During oil exchange once oil is drained:

Figure 8. Radiator

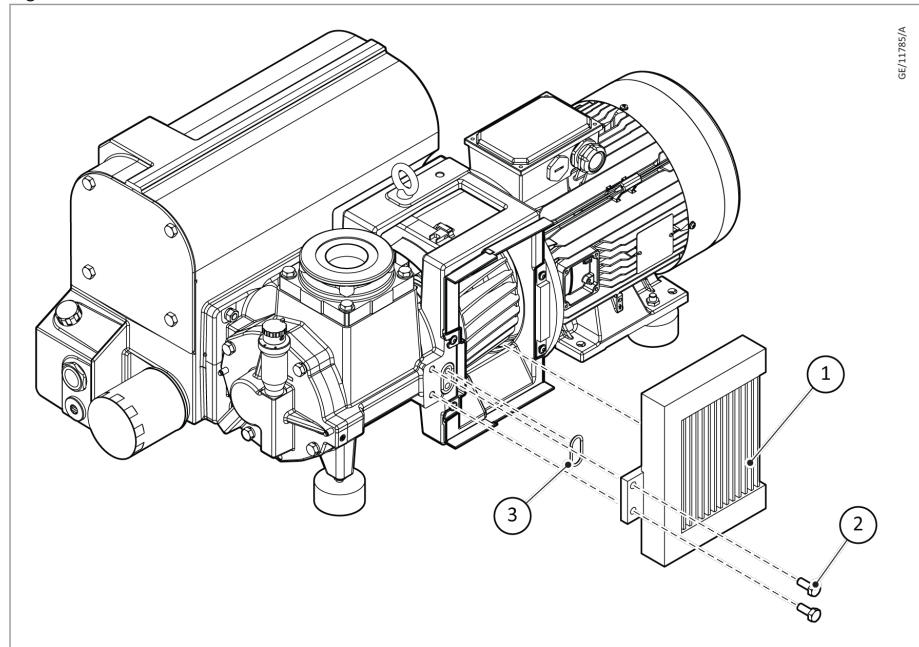

1. Radiator  
2. Screws  
3. O-ring

1. Remove the cooler (take care on the seal).
2. Clean the turbine and cooler with compress air and vacuum cleaner.
3. Reassemble the air oil cooler on the pump. Apply tightening torque of 47 N.m to the radiator screws.

## 8.10 Exhaust filter exchange

1. Remove the screws of the exhaust plate with a 16 mm wrench.
2. Remove the exhaust demister from the oil casing shake up and down and pull.
3. Make sure that the new exhaust filters have the O-ring (opposite side of overpressure valve) and grease them using our vacuum grease. (refer to [Table: Lubricants](#)).
4. Replace the O-ring on the casing (put vacuum grease in groove corners for O-ring retaining).
5. Insert new exhaust filter. It is guided in the oil casing.
6. Fit the screw and tight it progressively in alternation.

## 8.11 Clean the water/oil heat exchanger

- Make sure that the place is open and well ventilated.
- Observe the safety regulations given by the manufacturer of the product you are using.
- Observe the regulations for the treatment and the disposal of chemical products.
- Observe the relevant environmental regulations.

# Maintenance

Waterdrain the cooling circuit before transport, long time storage, winter time.

To drain the water circuit:

1. Close the water cooling.
2. Remove both the plugs.
3. Put a water recovery tray with a capacity of approximately 2 L under the heat exchanger.
4. Water may be hot, take appropriate safety measures.

For putting into operation again:

1. Fit the screw the 2 plugs into the heat exchanger.
2. Open the water circuit.

To clean the heat exchanger:

It is recommended to clean the water circuit at least twice a year.

1. Remove the exchanger from the pump.
2. Chemical cleaning is the most efficient, with dilute hydrochloric acid solution (5 to 10%) then neutralise with hexamethylethyrenetetramine at 0.2%.
3. For a 1 mm coat of scale, leave acting the acid during about 30 minute. The system must be open during the operations, so the product gases can escape.
4. Rinse copiously with water after neutralization.

# Fault finding

## 9 Fault finding

Table 6. Fault finding

Condition
<a href="#">Pump does not start</a> on page 32
<a href="#">Pump does not reach ultimate pressure</a> on page 32
<a href="#">Pumping speed is too low</a> on page 33
<a href="#">After switching off pump under vacuum, pressure in system rises too fast</a> on page 33
<a href="#">Pump gets too hot</a> on page 34
<a href="#">Oil in intake line or in vacuum vessel</a> on page 34
<a href="#">Oil is turbid</a> on page 35
<a href="#">Pump is excessively noisy</a> on page 35

Fault	Pump does not start
<b>Cause</b>	<b>Pump is connected incorrectly.</b>
Remedy	Connect the pump correctly. Refer to <a href="#">Electrical connections</a> on page 21.
<b>Cause</b>	<b>Motor protection switch set incorrectly.</b>
Remedy	Set motor protection switch properly. Refer to <a href="#">Electrical connections</a> on page 21.
<b>Cause</b>	<b>Operating voltage does not match motor.</b>
Remedy	Replace the motor.
<b>Cause</b>	<b>Motor is malfunctioning.</b>
Remedy	Replace the motor.
<b>Cause</b>	<b>Oil temperature is below 12 °C (54 °F).</b>
Remedy	Heat the pump and pump oil or use different oil.
<b>Cause</b>	<b>Oil is too viscous.</b>
Remedy	Use appropriate oil grade. Refer to <a href="#">Oil change and replace the oil filter</a> on page 28.
<b>Cause</b>	<b>Exhaust filter or exhaust line is clogged.</b>
Remedy	Replace the filter or clean the exhaust line. Refer to <a href="#">Clean the dirt trap</a> on page 28.
<b>Cause</b>	<b>Pump is seized up (pump is jammed).</b>
Remedy	Repair the pump.
Fault	Pump does not reach ultimate pressure
<b>Cause</b>	<b>Measuring technique or gauge is not suitable.</b>
Remedy	Use correct measuring technique and gauge. Refer to <a href="#">Pump ultimate pressure</a> on page 24.

# Fault finding

<b>Cause</b>	<b>External leak, piping fittings loose.</b>
Remedy	Repair the pump. Re-tighten the piping fittings.
<b>Cause</b>	<b>Float valve does not close.</b>
Remedy	Repair the valve. Refer to <a href="#">Exhaust filter exchange</a> on page 30.
<b>Cause</b>	<b>Anti-suckback valve is malfunctioning.</b>
Remedy	Repair the valve. Refer to Check the anti-suckback valve <a href="#">Check the anti-suck back valve</a> on page 29.
<b>Cause</b>	<b>Exhaust valve is malfunctioning.</b>
Remedy	Repair the valve. Refer to <a href="#">Clean the water/oil heat exchanger</a> on page 30.
<b>Cause</b>	<b>Inadequate lubrication due to unsuitable or contaminated oil.</b>
Remedy	Change the oil. Refer to <a href="#">Oil change and replace the oil filter</a> on page 28.
<b>Cause</b>	<b>Inadequate lubrication due to clogged oil filter.</b>
Remedy	Replace the oil filter. Refer to <a href="#">Oil change and replace the oil filter</a> on page 28.
<b>Cause</b>	<b>Inadequate lubrication due to clogged oil lines.</b>
Remedy	Clean the oil lines and oil case.
<b>Cause</b>	<b>Vacuum lines are dirty.</b>
Remedy	Clean vacuum lines.
<b>Cause</b>	<b>Pump is too small.</b>
Remedy	Check the process date, replace the pump, if necessary.

## **Fault Pumping speed is too low**

<b>Cause</b>	<b>Dirt trap in the intake port is clogged.</b>
Remedy	Clean the dirt trap. Refer to <a href="#">Clean the dirt trap</a> on page 28. Install a dust filter in intake line. Refer to <a href="#">Intake side</a> on page 19 and <a href="#">Connection fittings</a> on page 16.
<b>Cause</b>	<b>Exhaust filter is clogged.</b>
Remedy	Install new filter elements. Refer to <a href="#">Clean the dirt trap</a> on page 28.
<b>Cause</b>	<b>Connecting lines are too narrow or too long.</b>
Remedy	Use adequately wide and short connecting lines. Refer to <a href="#">Connection to system</a> on page 19.
<b>Cause</b>	<b>Anti-suckback valve is hard to open.</b>
Remedy	Check spring free length and clean.

## **Fault After switching off pump under vacuum, pressure in system rises too fast**

<b>Cause</b>	<b>System has a leak.</b>
Remedy	Check the system.

# Fault finding

<b>Cause</b>	<b>Anti-suckback is malfunctioning.</b>
Remedy	Repair the valve. Refer to <a href="#">Clean the gas ballast intake filter</a> on page 29.

## **Fault**      **Pump gets too hot**

<b>Cause</b>	<b>Cooling air supply is obstructed.</b>
Remedy	Set pump up correctly. Refer to <a href="#">Installation</a> on page 19.
<b>Cause</b>	<b>Cooler is dirty.</b>
Remedy	Clean the cooler. Refer to Radiator cleaning <a href="#">Clean the radiator</a> on page 30.
<b>Cause</b>	<b>Ambient temperature is too high.</b>
Remedy	Set pump up correctly. Refer to <a href="#">Installation</a> on page 19.
<b>Cause</b>	<b>Process gas is too hot.</b>
Remedy	Change the process.
<b>Cause</b>	<b>Oil level is too low.</b>
Remedy	Add oil to reach the correct oil level. Refer to <a href="#">Oil change and replace the oil filter</a> on page 28.
<b>Cause</b>	<b>Oil is not suitable.</b>
Remedy	Change the oil. Refer to <a href="#">Oil change and replace the oil filter</a> on page 28.
<b>Cause</b>	<b>Oil cycle is obstructed.</b>
Remedy	Clean or repair the oil lines.
<b>Cause</b>	<b>Exhaust filter/exhaust line is obstructed.</b>
Remedy	Replace the exhaust filter, clean the exhaust line. Refer to <a href="#">Clean the dirt trap</a> on page 28.
<b>Cause</b>	<b>Exhaust valve is malfunctioning.</b>
Remedy	Repair the valve. Refer to <a href="#">Clean the water/oil heat exchanger</a> on page 30.
<b>Cause</b>	<b>Pump module is no longer usable.</b>
Remedy	Replace the pump module.

## **Fault**      **Oil in intake line or in vacuum vessel**

<b>Cause</b>	<b>Oil comes from the vacuum system.</b>
Remedy	Check the vacuum system.
<b>Cause</b>	<b>Anti-suckback valve is obstructed.</b>
Remedy	Clean or repair the valve. Refer to <a href="#">Clean the gas ballast intake filter</a> on page 29.
<b>Cause</b>	<b>Sealing surfaces or anti-suckback valve are damaged or dirty.</b>
Remedy	Clean or repair the intake port and valve. Refer to <a href="#">Clean the gas ballast intake filter</a> on page 29.

# Fault finding

<b>Cause</b>	<b>Oil level is too high</b>
Remedy	Drain the excess oil. Refer to <a href="#">Oil change and replace the oil filter</a> on page 28.

---

<b>Fault</b>	<b>Oil is turbid</b>
<b>Cause</b>	<b>Condensation.</b>
Remedy	Degas the oil or change the oil and clean the pump. Refer to <a href="#">Pumping of condensable gases and vapour through gas ballast</a> on page 23. Open the gas ballast valve or insert a condensate trap. Refer to <a href="#">Oil condition</a> on page 27. Clean the gas ballast intake filter. Refer to <a href="#">Exchange of electrical motor</a> on page 29.

---

<b>Fault</b>	<b>Pump is excessively noisy</b>
<b>Cause</b>	<b>Oil level is very low (oil is no longer visible).</b>
Remedy	Add oil. Refer to <a href="#">Oil change and replace the oil filter</a> on page 28.
<b>Cause</b>	<b>Oil filter is clogged.</b>
Remedy	Change the oil and filter. Refer to <a href="#">Oil change and replace the oil filter</a> on page 28.
<b>Cause</b>	<b>Coupling element is worn.</b>
Remedy	Install new coupling element.
<b>Cause</b>	<b>Large vacuum leak in system.</b>
Remedy	Repair vacuum leak.

---

# Storage

## 10 Storage

The pump should be stored in a dry place, at room temperature (20 °C). Do not store the pump below 0 °C.

Before taking the pump out of service, disconnect it properly from the vacuum system, purge with dry nitrogen and change the oil. The inlet and exhaust ports of the pump must be blanked off with the shipping seals which are delivered with the pump. The gas ballast must be closed.

If the pump is to be stored for a longer period of time it must be sealed in a plastic bag together with a desiccant (Silica gel).

If the pump is to be shut down for an extended period or if the pump has to be stored, do as follows:

1. When pumping harmful substances, take adequate safety precautions.
2. Drain the oil (refer to [Oil change and replace the oil filter](#) on page 28).
3. Fill clean oil up to the bottom edge of the oil-level glass and let the pump run for a few minutes.
4. Then drain the oil and pour in clean oil up to the top edge of the oil-level glass.
5. Seal the connection ports.

## 11 Disposal

Dispose of the equipment safely in accordance with all local and national safety and environmental requirements.

Detailed disposal and recycling instructions are available, contact us for more information.

## 12 Service

### 12.1 Return the equipment or components for service

Before you send your equipment to us for service or for any other reason, you must complete a Declaration of Contamination Form. The form tells us if any substances found in the equipment are hazardous, which is important for the safety of our employees and all other people involved in the service of your equipment. The hazard information also lets us select the correct procedures to service your equipment.

If you are returning equipment note the following:

- If the equipment is configured to suit the application, make a record of the configuration before returning it. All replacement equipment will be supplied with default factory settings.
- Do not return equipment with accessories fitted. Remove all accessories and retain them for future use.
- The instruction in the returns procedure to drain all fluids does not apply to the lubricant in pump oil reservoirs.

Download the latest documents from [leybold.com/en/downloads/download-documents/declaration-of-contamination/](http://leybold.com/en/downloads/download-documents/declaration-of-contamination/), follow the procedure in HS1, fill in the electronic HS2 form, print it, sign it, and return the signed copy to us.



#### **NOTICE:**

**If we do not receive a completed form, your equipment cannot be serviced.**

---

## 13 Accessories

Description	SV 220 B/220 FP
Oil drain tap (size G" 3/4) with nipple	GK6701610
Gas ballast manual 4 position	GK6703134
Electromagnetic gas ballast 16KF	GK6704190
Manual gas ballast 2 position 16KF	GK6704191
Big gas ballast 16KF	9600GGB
Gas ballast intake filter	Please consult us
Exhaust filter gauge	95194
Exhaust filter overpressure switch	971471210
Oil level monitor	Please consult us
Thermal switch (105 °C)	971463930
PT100	971444320
Adapter roots 500	GK971463861
Adapter roots 1000	GK971456541

Consult us for retrofit. Our service department can carry out these upgrades.

Stability of pump is insured with original accessories, mounting of any other accessory will engage the responsibility of user concerning stability of pump.

**Table 7. Consumables**

Description	SV 220 B/220 FP
Oil filter by-pass left thread	G6541596
Oil filter standard	E6537380
Maintenance kit (Exhaust filter with O-ring to be replaced)	EK9606M
For some maintenance operation described in the manual it is necessary to add the corresponding kits:	
Yearly maintenance kit	GK9606M1

Exhaust filter are not sold alone they are replaced by maintenance kit.

**Table 8. Tools required**

Tool	Part number
Oil filter key - Allen key male 12 mm	71073532
Anti-suck back valve - adjusting ring	71072333



Pioneering products. Passionately applied.

Leybold GmbH  
Bonner Strasse 498  
50968 Cologne  
GERMANY  
+49-(0)221-347-0  
info@leybold.com  
www.leybold.com