

NOZZLE SCHEDULE		
IDENTIFIER	CONNECTION	SIZE
A	SYSTEM INLET	2" FNPT
B	SYSTEM DISCHARGE	2" FNPT
C	OIL DRAIN	G 3/4"

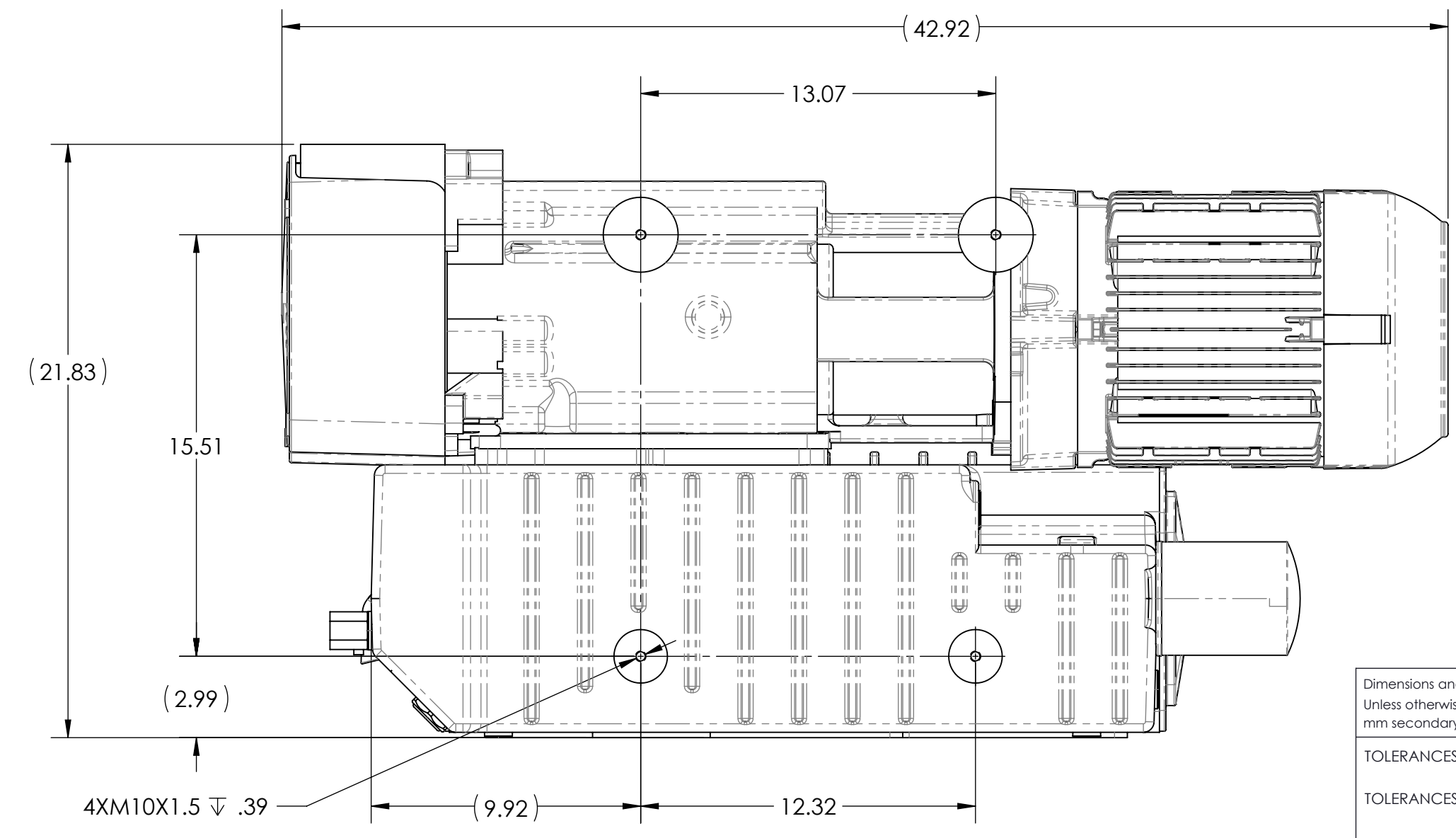
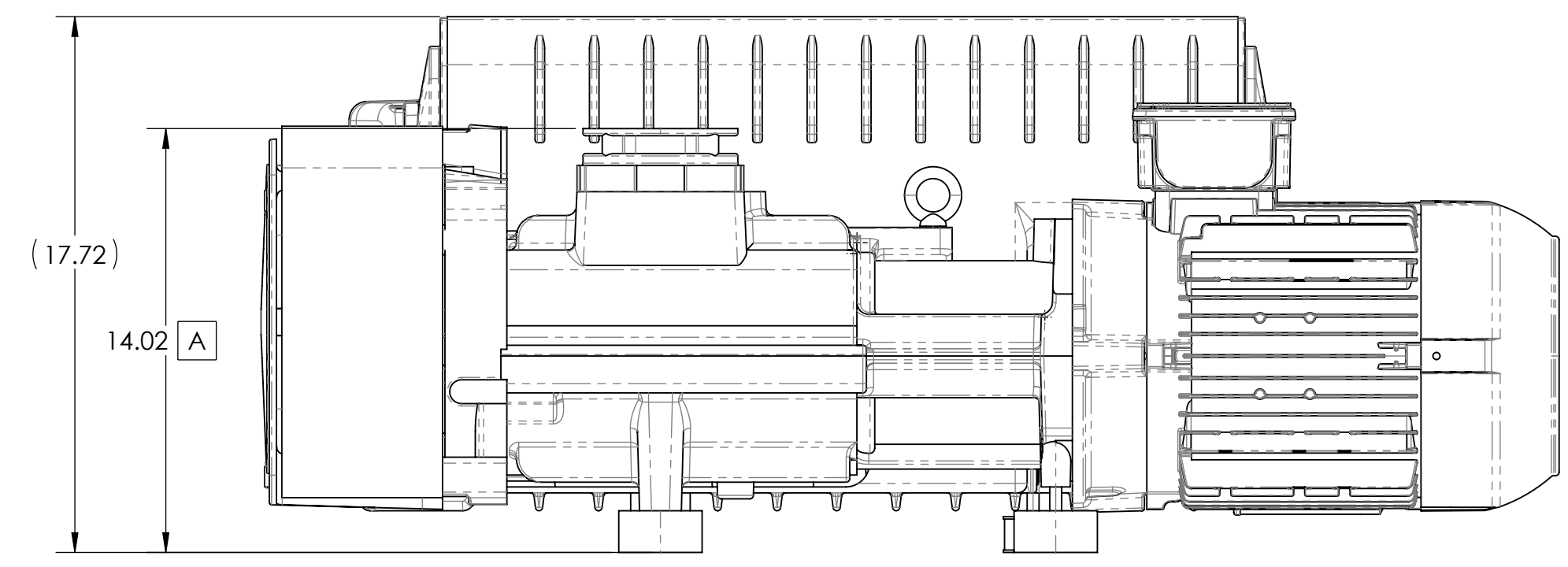
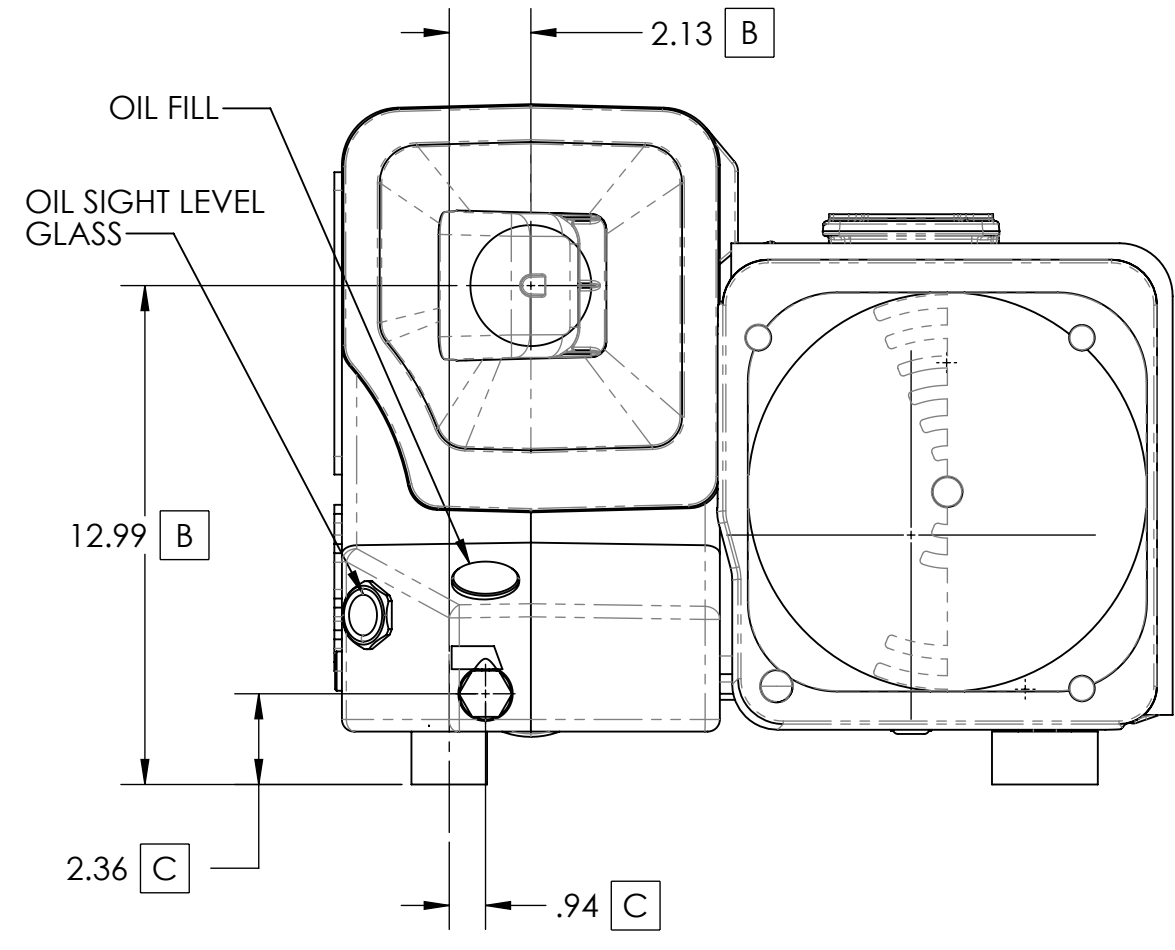
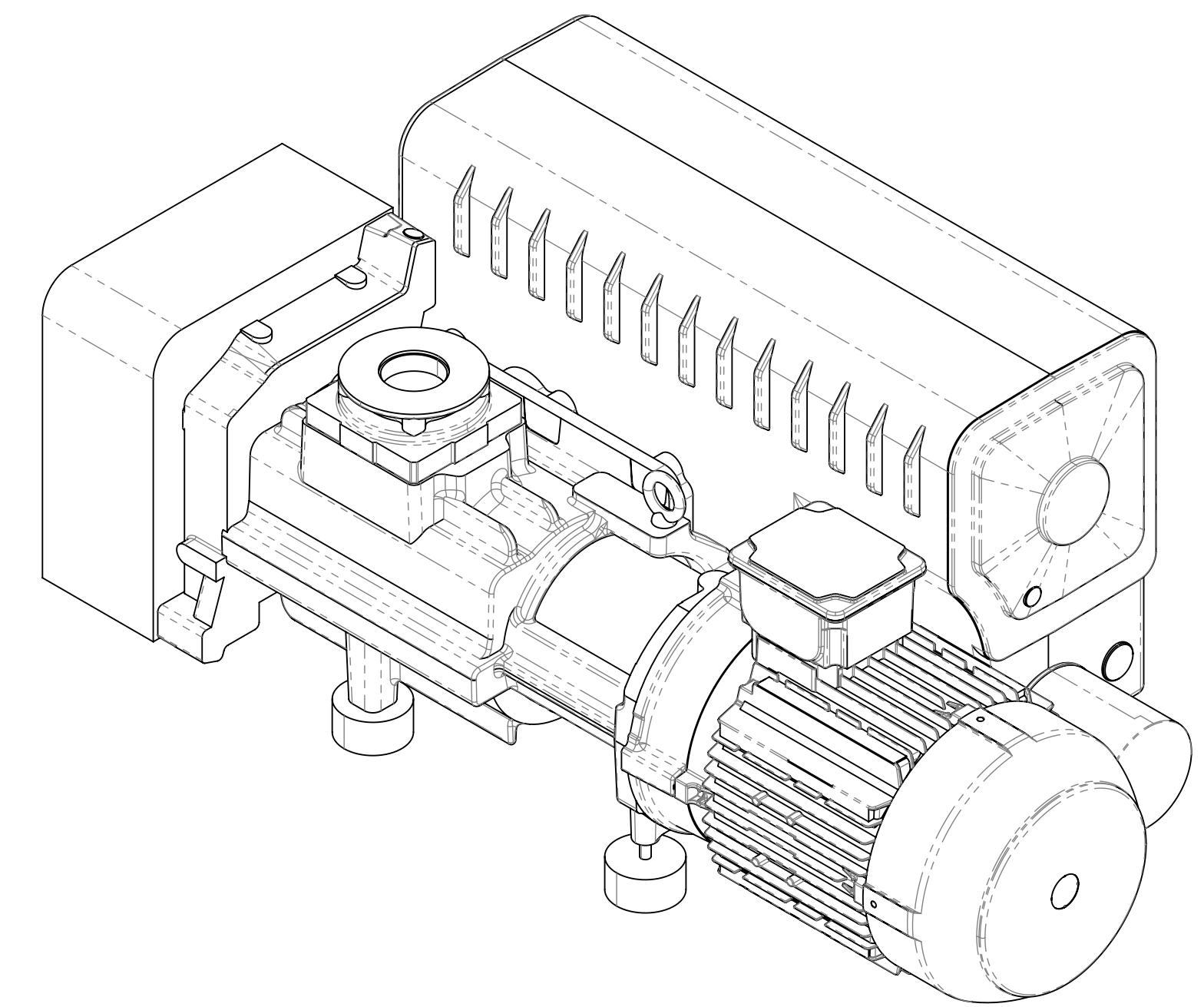
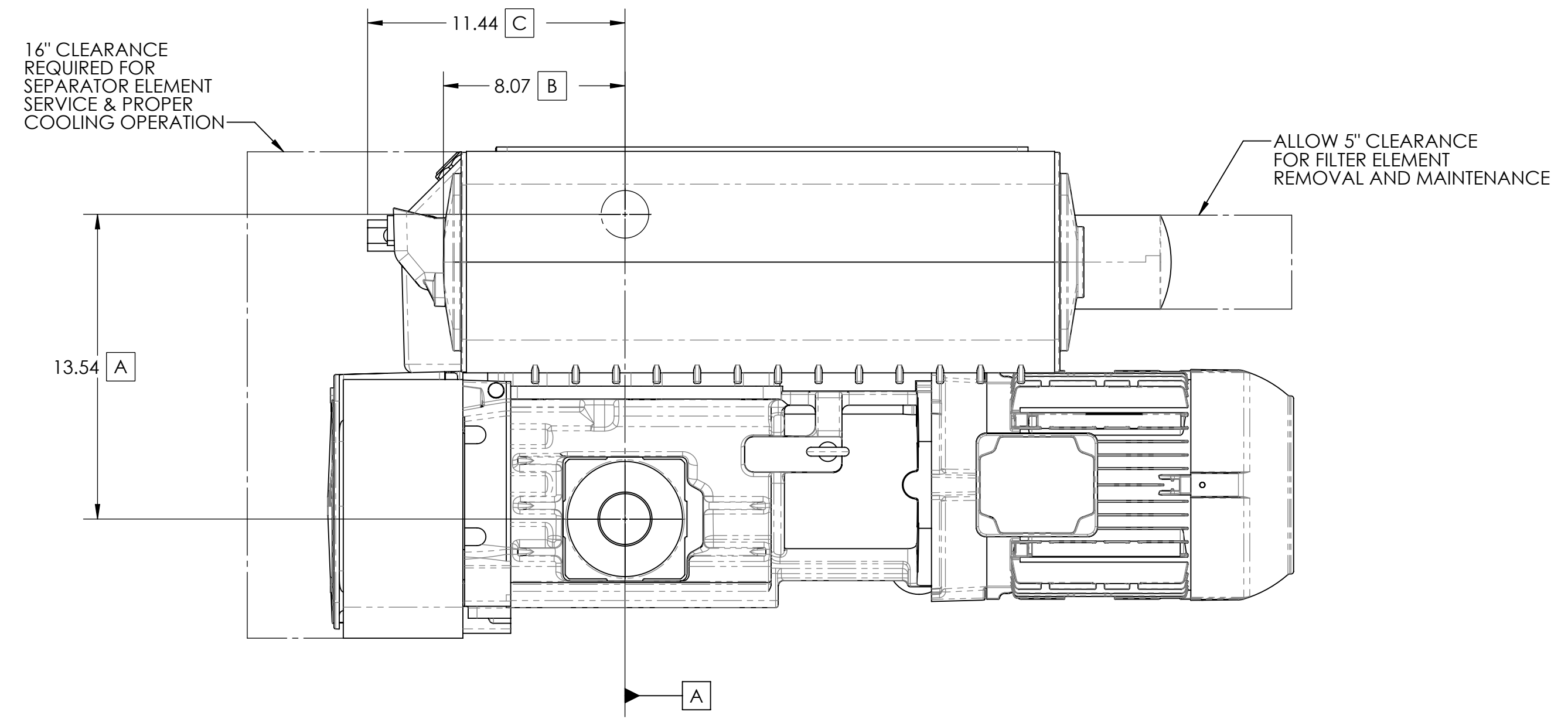

FINAL PRENOTES:
 1) LOCATE VACUUM PUMP ON FLAT LEVEL SURFACE.
 2) PLUG ALL UNUSED PORTS WITH NPT PLUG.

<small>Dimensions and tolerances in accordance with ASME 1.4.5M-1994 Unless otherwise specified all dimensions are inches primary, mm secondary.</small>		Name PUMP RV 1STG LUBR 200 CFM 3/200-230/460				Confidentiality Class acc. to 1102K Confidential													
TOLERANCES ON ANGLES ±.50° TOLERANCES ON 2 PLACE DIMS ±.50° TOLERANCES ON 3 PLACE DIMS ±.062° FINISH ON MACHINED SURFACE		Material SEE DRAWING Finish SEE DRAWING		Scale 1:5 Family PRODUCTION		Similar to			Drawing Owner 2023884 SHEET NO. 1 OF 1										
Parent 3D model Ed. Version 3D				Drawn by NGJ Version Drwg Blank Wt.		Make From Designation QV10HS32		Replaces											
REVISIONS <table border="1"> <thead> <tr> <th>REV.</th> <th>DESCRIPTION</th> <th>DATE</th> <th>DWG</th> <th>ERP</th> <th>APP</th> </tr> </thead> <tbody> <tr> <td> </td> <td> </td> <td> </td> <td> </td> <td> </td> <td> </td> </tr> </tbody> </table>		REV.	DESCRIPTION	DATE	DWG	ERP	APP								STATUS PRELIMINARY		Fin. Wt. 476.20 LB Date 09/23/23		Confidentiality Class acc. to 1102K Confidential
REV.	DESCRIPTION	DATE	DWG	ERP	APP														

All materials supplied in compliance with the requirements of the List of Prohibited Substances

CONFIDENTIAL
 This document is the property of Quincy Compressor LLC and shall not be without our permission be used for any other purpose, reproduction, manufacturing or distribution in any form.

NOZZLE SCHEDULE		
IDENTIFIER	CONNECTION	SIZE
A	SYSTEM INLET	2" FNPT
B	SYSTEM DISCHARGE	2" FNPT
C	OIL DRAIN	G 3/4"

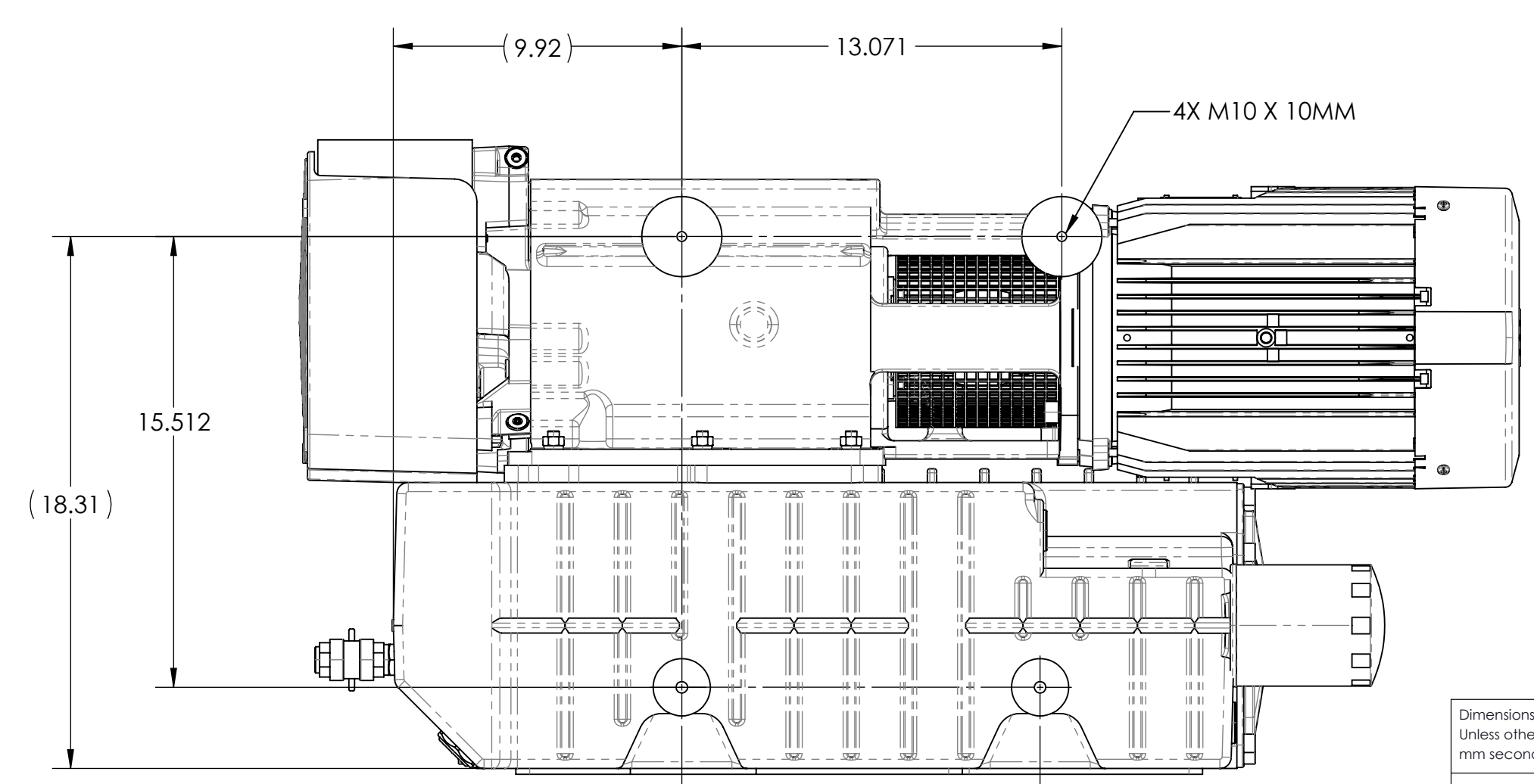
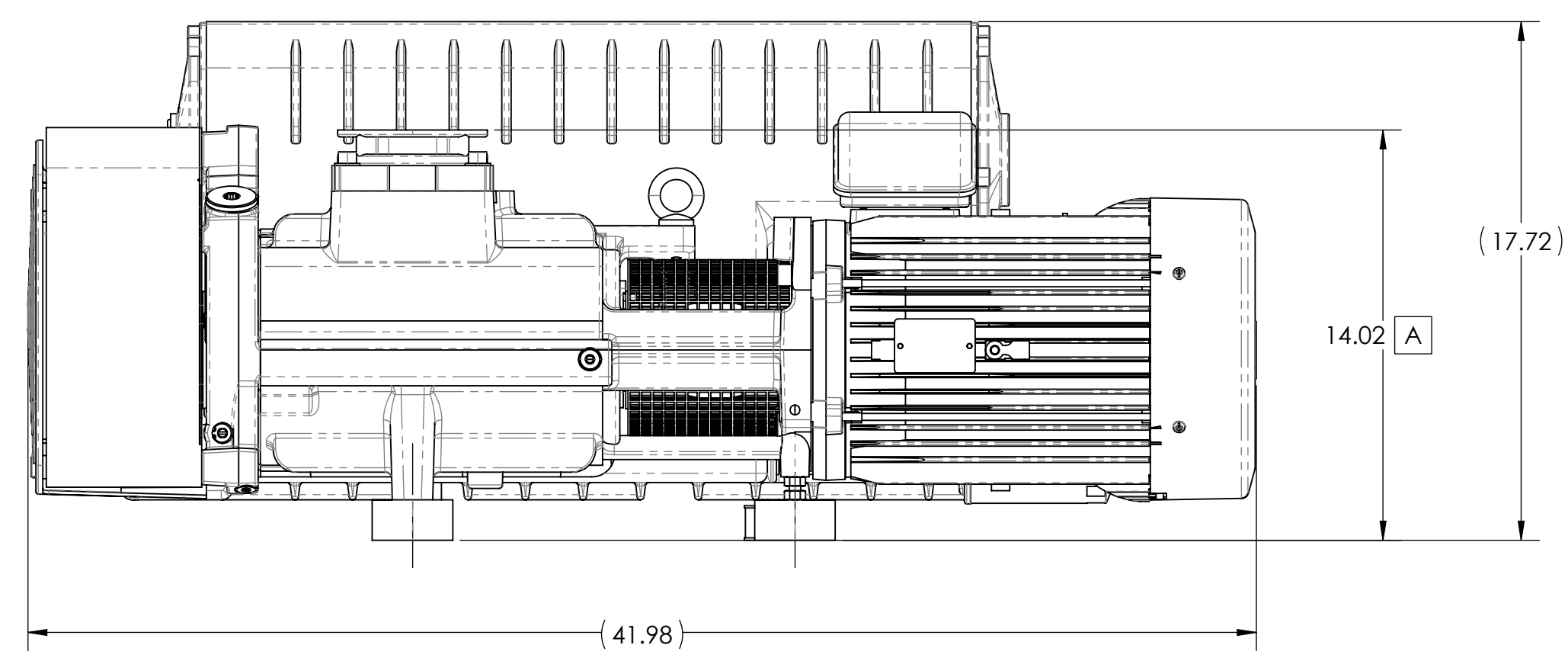
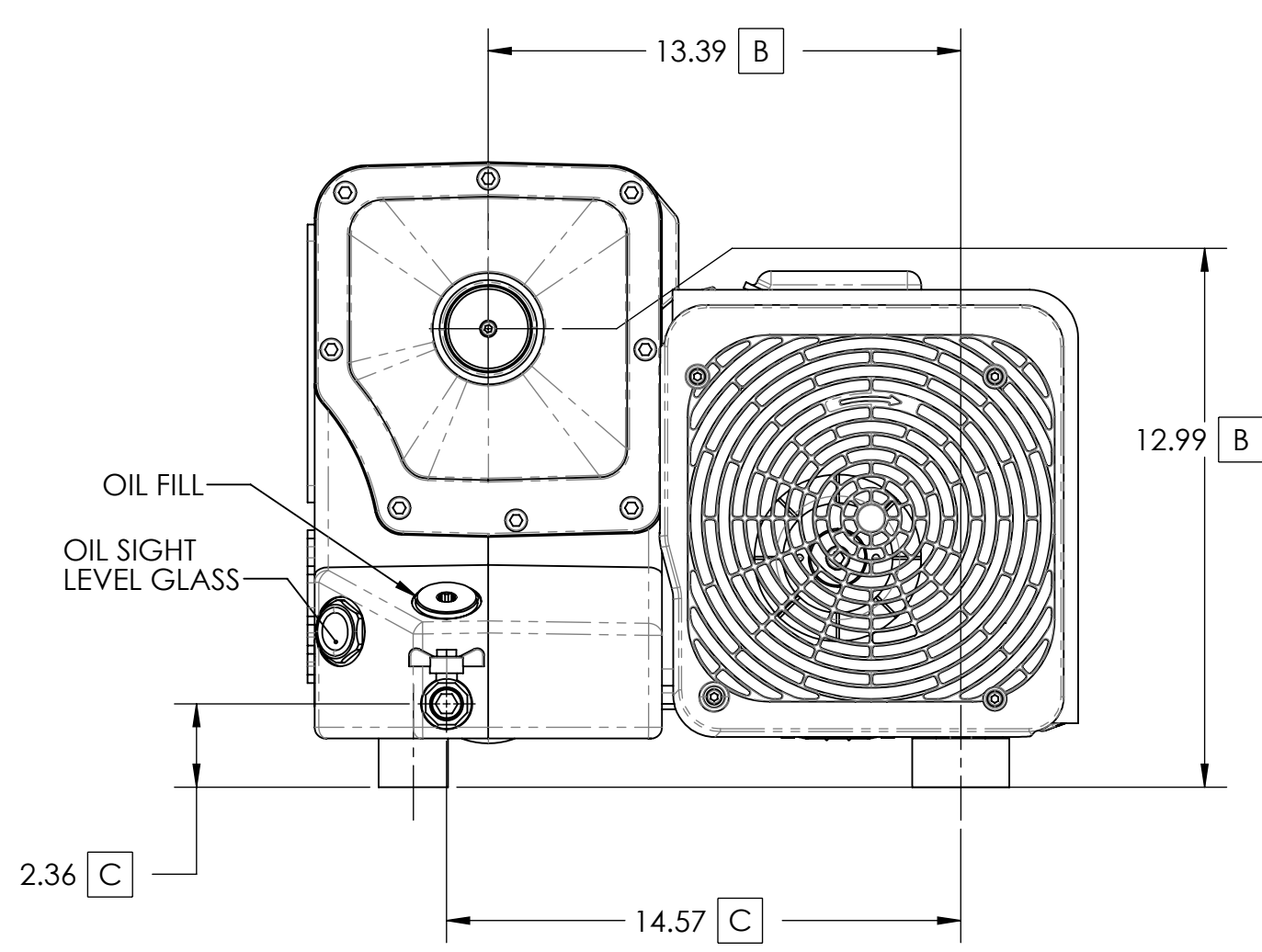
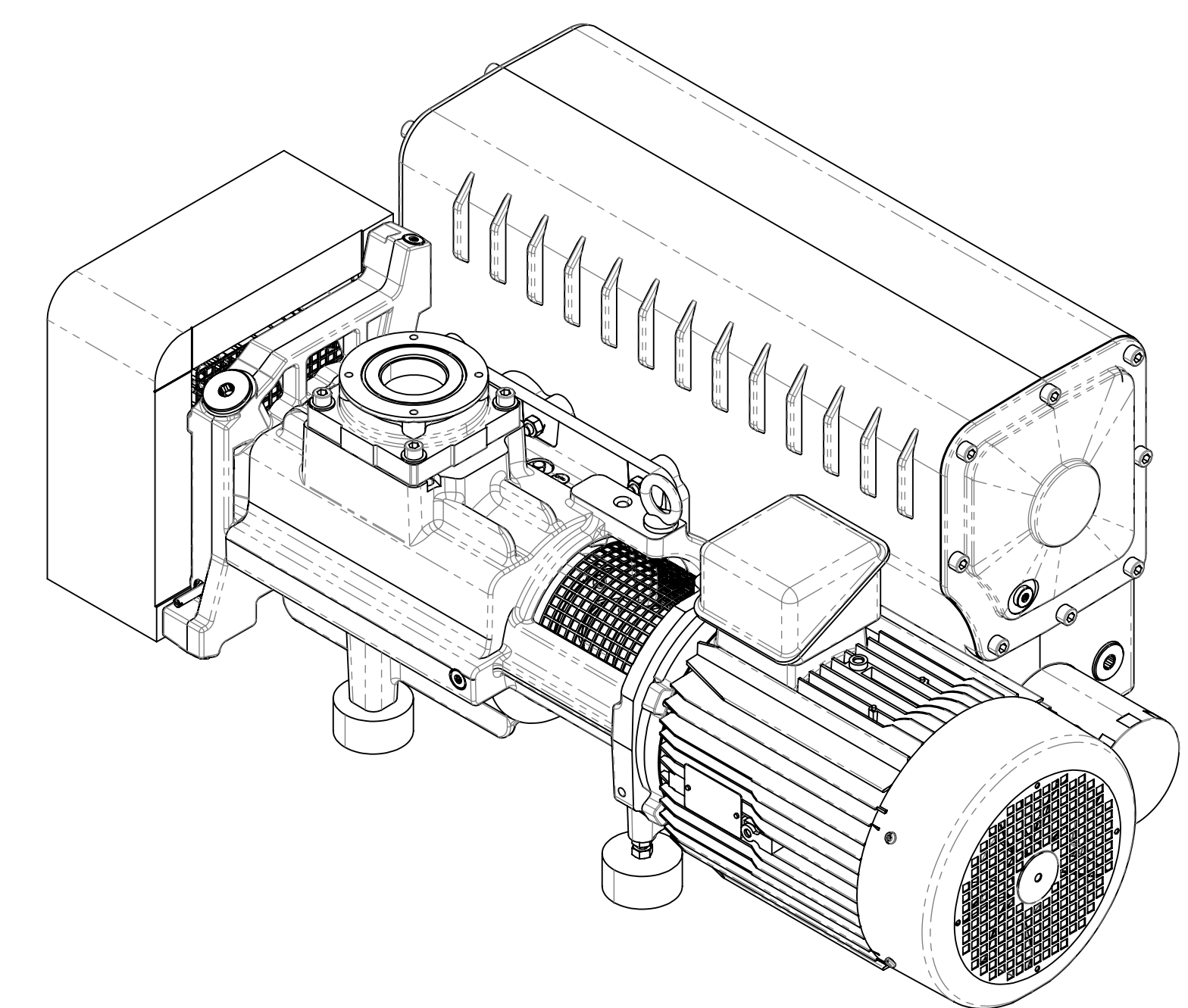
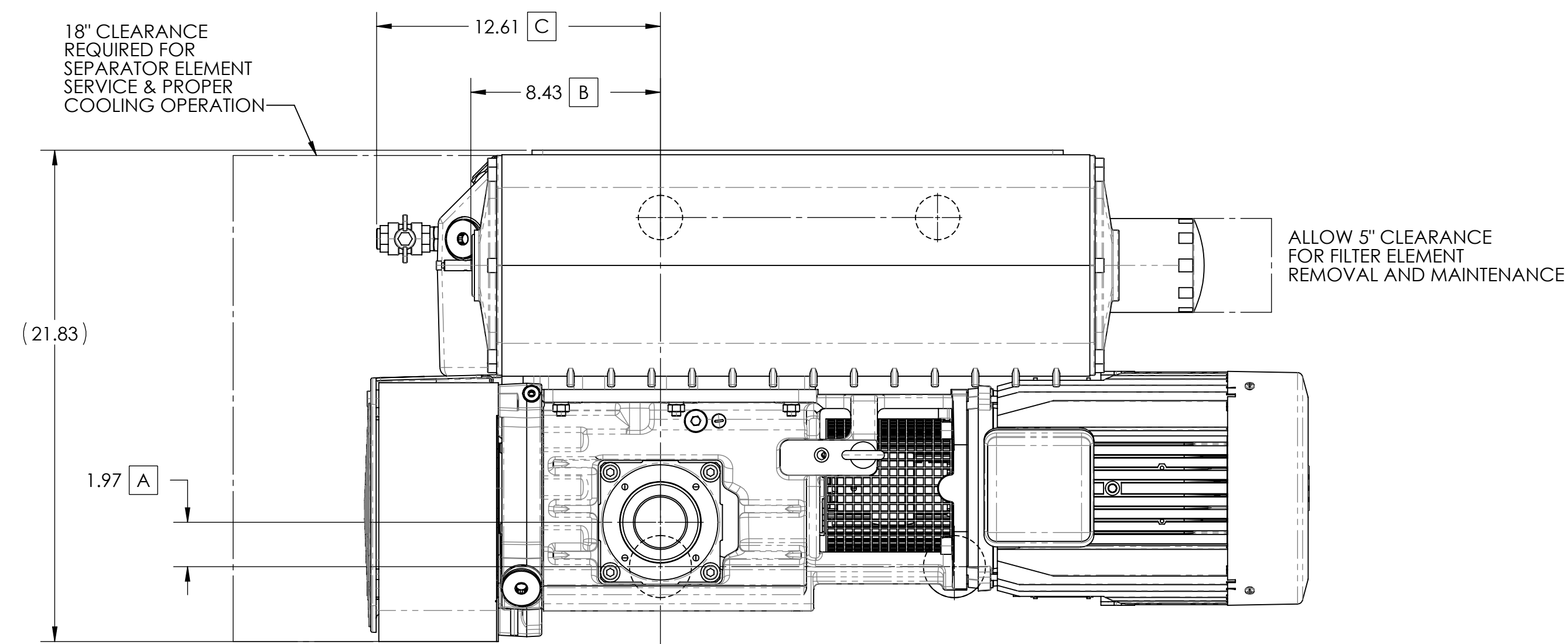

NOTES:
 1) LOCATE VACUUM PUMP ON FLAT LEVEL SURFACE.
 2) PLUG ALL UNUSED PORTS WITH NPT PLUG.

Dimensions and tolerances in accordance with ASME Y14.5M-1994
 Unless otherwise specified all dimensions are inches primary,
 mm secondary.

TOLERANCES ON ANGLES ±.50°
 TOLERANCES ON 2 PLACE DIMS ±.01°
 TOLERANCES ON 3 PLACE DIMS ±.002°
 FINISH ON MACHINED SURFACE

Name		PUMP RV 1 STG LUBR 200 CFM 575V/3/60				Confidentiality Class		acc. to 1102K	Drawing Owner				
Material		SEE DRAWING				Confidential							
Finish		SEE DRAWING				Scale		1:5	Family	PRODUCTION	D	Similar to	
STATUS		PRELIMINARY		Des Checked R.C		Prod Checked R.C		Approved RHC		Date		09/23/23	
Parent 3D model		Ed. Version 3D		Version Drwg		Blank Wt.		Fini Wt. LB		511.50 LB		Replaces	2023885
												Designation	QV10HW11

REVISIONS					
REV.	DESCRIPTION	DATE	DWG	ERP	APP

All materials supplied in compliance with the requirements of the List of Prohibited Substances

CONFIDENTIAL
 This document is the property of Quincy Compressor LLC and shall not be without our permission be used for any other purpose, reproduction, manufacturing or distribution by any third party.