

**AIRTECH** oil-flooded, multi-vane vacuum pumps are single stage, air cooled and direct driven. This simple design ensures the reliability and the durability that is required in the vacuum industry.

### Standard Equipment:

- High performance carbon composite vanes
- Oil level sight glass
- Vibration isolators
- Anti-suck back valve
- Integral exhaust filters
- TEFC high efficiency tri-voltage motor (208-230/460V 50/60)
- Exhaust pressure gauge
- Wire mesh inlet screen
- Spin-on oil filter

### Performance Curves

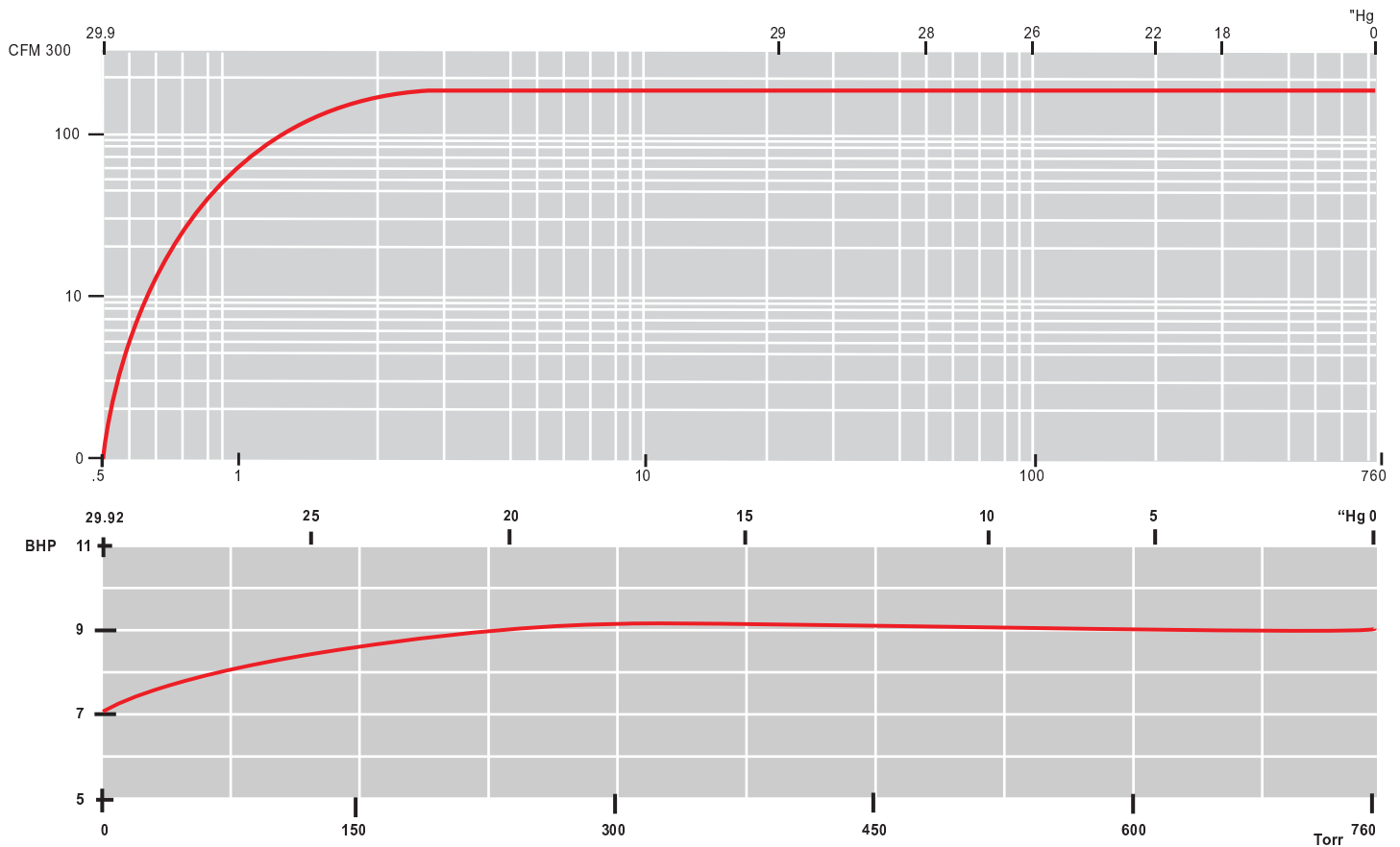

### Dimensions (inches):

Specifications are subject to change without notice. Please contact factory for specification updates.

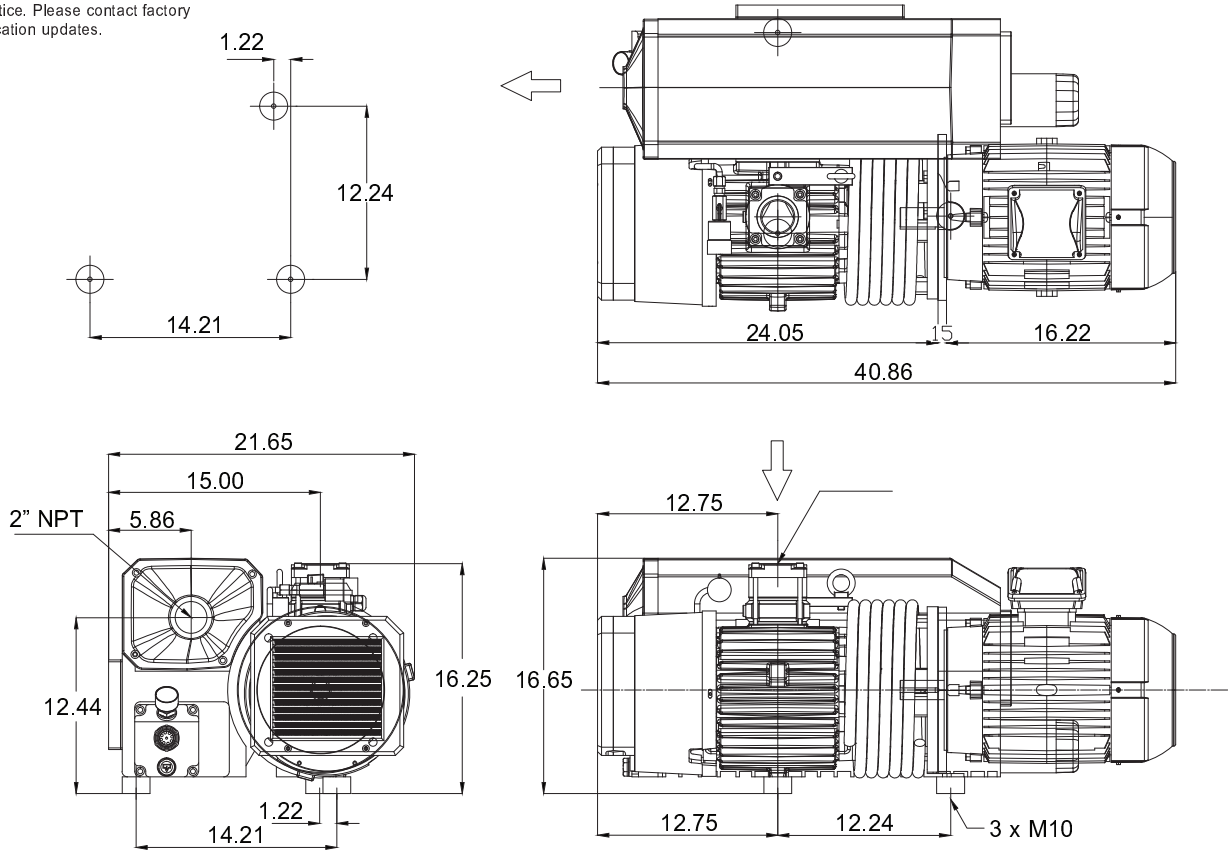

### Specifications:

Model	<b>250E</b>
Free Air Displacement [CFM] 60 Hz	180
Motor Capacity [HP] 60 Hz	10
Speed [RPM] 60 Hz	1725
Sound Level [dB(A)] 60 Hz	74
End Vacuum [Torr]	0.5
Weight [Lbs] [with motor]	407
Oil quantity [Qts]	7