

VARODRY

VD65/VD100/VD160/ VD200

Operating instructions 300766038_002_C3

Part No.

111065Vxx

111100Vxx

111160Vxx

111200Vxx



Copyright notice

©Leybold GmbH. All rights reserved.

Trademark credit

Leybold and the Leybold logo are trademarks of Leybold GmbH, Bonner Strasse 498, D-50968 Cologne.

Contents

| | |
|---|-----------|
| 1 Safety and compliance. | 6 |
| 1.1 Definition of Warnings and Cautions. | 6 |
| 2 Important Safety Information. | 7 |
| 2.1 Mechanical hazards. | 7 |
| 2.2 Electrical hazards. | 7 |
| 2.3 Thermal hazards. | 8 |
| 2.4 Hazards caused by materials and substances. | 8 |
| 2.5 Noise hazard. | 8 |
| 2.6 Risk of damaging the pump. | 8 |
| 3 Description. | 9 |
| 3.1 Supplied equipment. | 9 |
| 3.2 Technical data. | 10 |
| 3.3 Accessories. | 11 |
| 4 Transport and storage. | 13 |
| 5 Installation. | 14 |
| 5.1 Placement. | 14 |
| 5.2 Conforming use. | 14 |
| 5.2.1 Non-conforming use. | 15 |
| 5.3 Connect the pump. | 15 |
| 5.4 Removal of pump cover. | 16 |
| 5.5 Electrical connection. | 16 |
| 5.6 Optional VFD use. | 17 |
| 5.7 Purge gas/Gas ballast connection (optional). | 17 |
| 5.8 Manual Gas Ballast Configuration. | 18 |
| 5.9 Connecting solenoid gas ballast/purge valves. | 19 |
| 6 Operation. | 20 |
| 6.1 Switching off. | 20 |
| 7 Maintenance. | 21 |
| 7.1 Maintenance schedule. | 21 |
| 7.2 Tools required for maintenance. | 22 |
| 7.3 Pump timing belt change. | 22 |

Contents

| | |
|--|-----------|
| 7.4 Replace the belt. | 23 |
| 7.4.1 Disassemble drive enclosure. | 23 |
| 7.4.2 Disassemble rotor disc, screw and fan. | 24 |
| 7.4.3 Disassemble belt chamber cover. | 24 |
| 7.4.4 Disassemble fail safe gears. | 25 |
| 7.4.5 Disassemble belt. | 26 |
| 7.4.6 Assemble tooth belt. | 27 |
| 7.4.7 Assemble motor screw. | 28 |
| 7.4.8 Assemble fail safe gear. | 28 |
| 7.4.9 Assemble belt chamber cover. | 30 |
| 7.4.10 Assemble fan. | 31 |
| 7.4.11 Assemble drive enclosure. | 31 |
| 7.4.12 Electric connection. | 32 |
| 7.4.13 Verify motor rotation. | 32 |
| 7.5 Blow off valve cleaning. | 33 |
| 7.6 Replace electrical motor. | 34 |
| 7.6.1 Motor disassembly. | 34 |
| 7.6.2 Motor assembly. | 38 |
| 7.7 Table: Motor part list. | 42 |
| 8 Troubleshooting. | 44 |
| 9 Disposal. | 46 |
| 9.1 Waste disposal. | 46 |
| 10 Leybold Service. | 47 |

List of Figures

| | |
|---|----|
| Figure 1. Dimensional drawing (mm). | 11 |
| Figure 2. Transportation of the pump. | 13 |
| Figure 3. Connections and controls. | 14 |
| Figure 4. Remove the cover. | 16 |
| Figure 5. Electrical connection. | 17 |
| Figure 6. Arrow - direction of rotation. | 17 |
| Figure 7. Manual gas ballast configuration. | 18 |
| Figure 8. Connecting solenoid gas ballast/purge valves. | 19 |
| Figure 9. Tools required for maintenance. | 22 |
| Figure 10. Blow off valve cleaning. | 34 |

Safety and compliance

1 Safety and compliance

1.1 Definition of Warnings and Cautions

NOTICE:

For safe operation from the start, read these instructions carefully before you install or commission the equipment and keep them safe for future use.



Read all the safety instructions in this section and the rest of this manual carefully and make sure that you obey these instructions. The equipment must only be operated and maintained by trained personnel in the proper condition and as described in this instruction manual.

Obey local and state requirements and regulations. If you have any questions about safety, operation or maintenance of the device, please contact our nearest subsidiary.

Important safety information is highlighted as warning and caution instructions. Obey these instructions.



WARNING:

If you do not obey a warning, there is a risk of injury or death. Different symbols are used according to the type of hazard.



CAUTION:

If you do not obey a caution, there is a risk of minor injury, damage to equipment, related equipment or process.



NOTICE:

Information about properties or instructions for an action which, if ignored, will cause damage to the equipment.

We reserve the right to change the design and the stated data. The illustrations are not binding.

Keep the instructions for future use.

Important Safety Information

2 Important Safety Information

Pressures given in bar or mbar are absolute values. If exceptionally a gauge pressure is meant, a "g" is added (for example, bar (g)).

2.1 Mechanical hazards



WARNING:

When rotated in the wrong direction, the pump will generate up to 4.5bar (g) pressure at the inlet. If a vacuum system is connected, the pressure build up can lead to explosion of the system.

1. Avoid exposing any part of the human body to the vacuum.
2. Select a secure place for the appliance (level surface).
3. Never operate the pump without a connected intake line or without fitting a blank flange.
4. The discharge port of the pump must not be blocked or constricted. Never operate the pump with a seal-off stopper in place blanking off the exhaust port. Operate the pump only with a connected vacuum system to the intake flange.
5. With a closed exhaust pipe, the pump can generate up to 1.5 bar (g) overpressure on the exhaust. The exhaust pipes should be laid out accordingly.
6. Condensates from the pump can collect inside or at the exhaust, escape and spill onto the floor, when operating the pump without an exhaust line or during transport with an exhaust being not blanked off. In this case there exists the risk of slipping.
7. Take note of the labelling of inlet and outlet. A mix-up can lead to dangerous build-up of pressure in the vacuum system or in the system. After each change of the electrical connection, check the pump's rotational direction.
8. In case of power supply outage, the vacuum system is ventilated by the pump. If this is not wanted, install a non-return valve at the inlet.
9. After a loss of power, the pump restarts independently. If this is not wanted, install a restart inhibitor.
10. Do not operate the pump with any of the covers removed. This may result in serious injury.

2.2 Electrical hazards



DANGER:

After a mains power failure the pump will run up automatically again. This also applies in the case of an emergency shut-down. In order to prevent the pump from running up automatically again, the pump must be integrated within a control arrangement such that it can only be switched on manually again after the mains power has returned.

1. Housing parts must not be removed.
2. The electrical connection must only be provided by a trained person.
3. Obey the national regulations in the country of use like EN 50110-1 for Europe.

Important Safety Information

4. Note the information on the IP type of protection.

2.3 Thermal hazards



CAUTION:

The surface of the pump may attain temperatures over 80 °C. There is the risk of burn injury.

-
1. Before servicing and maintenance work, always leave the pump to cool down.

2.4 Hazards caused by materials and substances



DANGER:

Before commissioning the pump, make sure that the media which are to be pumped are compatible with each other so as to avoid hazardous situations. Observe the instructions for proper and improper use of the pump in Conforming Use.

2.5 Noise hazard



CAUTION:

The noise level of the pump during ultimate pressure operation corresponds to the values stated in the technical data. In other operating modes and depending on the connected vacuum system, higher values can be expected. Make sure that suitable protection measures are taken to protect your hearing.

2.6 Risk of damaging the pump

-
1. Before starting up for the first time, the motor circuit must be equipped with a suitable protective motor switch. Please take note of the information in these Operating Instructions and on the electric motor (wiring diagram).
 2. Do not allow the ingestion of objects (screws, nuts, washers, pieces of wire, etc.) through the inlet port. If required, use an inlet filter.
 3. Do not use the pump for applications that produce abrasive or adhesive powder vapour sales or service department for advice.
 4. This pump is suited for pumping water vapour within the specified water vapour tolerance limits.
 5. Avoid vapour that can condense into liquids when being compressed inside the pump, if these substances exceed the vapour tolerance of the pump.
 6. In the case of wet processes we recommend the installation of liquid separators upstream and downstream of the pump as well as the use of the gas ballast.
 7. The exhaust line should be laid so that it slopes down and away from the pump so as to prevent condensate from back streaming into the pump.
 8. Avoid the entry of particles and fluids.
 9. The air intakes of the pump and the motor must remain free.

3 Description

The pump is a dry-compressing vacuum pump and can evacuate containers in the rough vacuum range.

The pump is connected to a 3-phase network on the motor terminal board and operated directly from the mains. It is air-cooled and requires minimum maintenance.

3.1 Supplied equipment

The pump is delivered ready for operation. Intake and exhaust flanges are covered with caps.

Description

3.2 Technical data

Table 1 Technical data

| VARODRY | 65 | 100 | 160 | 200 |
|--|--|-----------------------|-----------------------|-----------------------|
| Maximum pumping speed without gas ballast | 65 m ³ /h | 105 m ³ /h | 150 m ³ /h | 200 m ³ /h |
| Ultimate pressure without gas ballast | 0.01 mbar | | | |
| Ultimate pressure with gas ballast | 0.1 mbar | | | |
| Maximum permissible inlet pressure | 1200 mbar | | | |
| Maximum permissible discharge pressure (Relative to ambient) ⁵⁾ | 200 mbar | | | |
| Water vapour tolerance with gas ballast ⁴⁾ | 60 mbar | | | |
| Water vapour capacity with gas ballast ⁴⁾ | 1.9 kg/h | 2.9 kg/h | 5.2 kg/h | 6.9 kg/h |
| Permissible ambient temperature | 0 to +40 °C | | | |
| Storage temperature | -20 to +60 °C | | | |
| Purge gas consumption | 5 slm | | | |
| Purge gas supply pressure (optional) | 2-4 bar (g) | | | |
| Gas consumption exhaust purge (optional) | 7.5-16 slm | | | |
| Gas consumption inlet purge (optional) | 2.5-5 slm | | | |
| Noise level without external silencer, at ultimate pressure (according to DIN EN ISO 2151) | | | | |
| ▪ 50 Hz versions | 67 dB(A) | | 70 dB(A) | |
| ▪ 60 Hz versions | 70 dB(A) | | 73 dB(A) | |
| Relative ambient atmospheric humidity | 95%, non-condensing | | | |
| Maximum installation height ¹⁾ | Up to 1000 m above sea level | | | |
| Cooling | Air | | | |
| Mains voltage 50 Hz versions ²⁾ | 400 V ± 10% or 200 V ± 10% | | | |
| Mains voltage 60 Hz versions ²⁾ | 460 V ± 10% or 230 V ± 10% or 200/380 V ± 10% , 3 ph | | | |
| Phases | 3-ph | | | |
| Maximum current 50 Hz versions 200/400 V ³⁾ | 6.4/3.2 A | 8.6/4.3 A | 13.0/6.7 A | 15.5/7.5 A |
| Maximum current 60 Hz versions 230/460 V ³⁾ | 5.6/2.8 A | 7.6/3.8 A | 11.3/5.7 A | 13.7/6.5 A |
| Maximum current 60 Hz versions 200/380 V ³⁾ | 6.0/3.4 A | 8.3/4.6 A | 12.8/6.9 A | 15.5/8.9 A |
| Maximum power consumption | 1500 W | 2200 W | 3000 W | 4000 W |
| Permissible motor speed ²⁾ | 50/60 Hz | | | |
| Protection class | IP 55 | | | |
| Intake connection | G 2" | | | |
| Discharge flange DN | G 1 1/2" | | | |
| Weight (approximate) | 105 kg | 115 kg | 130 kg | 140 kg |

1) Please inquire for installation heights above 1000 m.

2) Depending on version 50 or 60 Hz. Please see pump nameplate.

3) Motor protective switch must be suitable for operation with IE3 motors.

Description

4) Depending on installed configuration. Please see [Purge Gas/Gas Ballast Connection \(optional\)](#) on page 17 for details.

5) Up to 200 mbar possible depending on the inlet pressure of the pump. With higher outlet pressure, the ultimate pressure will be higher.

Figure 1. Dimensional drawing (mm)

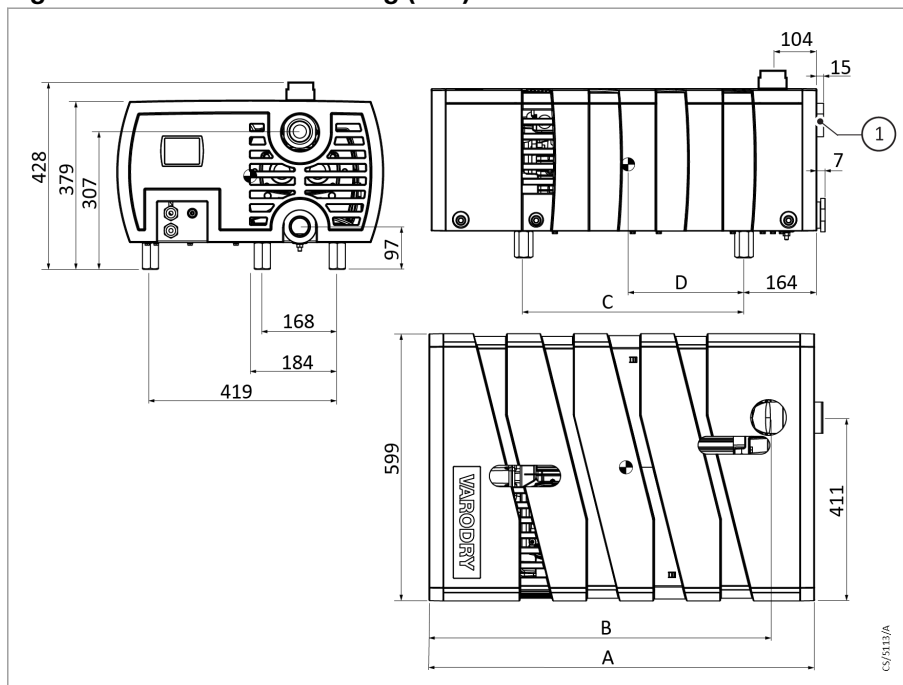

1. *Optional inlet position*

| Variable dimensions | VD65 | VD100 | VD160 | VD200 |
|---------------------|------|-------|-------|-------|
| A | 773 | 865 | 1060 | 1060 |
| B | 670 | 762 | 957 | 957 |
| C | 402 | 494 | 647 | 647 |
| D | 253 | 294 | 370 | 370 |

3.3 Accessories

Table 2 Accessories

| | |
|--|-----------|
| Centering ring, aluminium, FPM DN 40 ISO-KF | 18208 |
| Clamping ring, aluminium DN 40 ISO-KF | 18343 |
| Inlet adapter G 1¼" | 111005A21 |
| Inlet adapter DN40 ISO-KF | 111005A20 |
| Inlet adapter DN63 ISO-K | 111005A24 |
| Exhaust adapter DN40 ISO-KF | 111005A30 |
| Replacement timing belt 50 Hz versions | EK6528531 |
| Replacement timing belt 60 Hz versions | EK6528533 |
| Belt replacement tool kit | EK6530942 |
| Pump flushing kit | 111005A00 |
| Inlet non return valve (for operation > 10 mbar) | 111005A15 |
| Inlet adapter NPT 1¼ - 11.5 | 111005A22 |
| Inlet adapter NPT 2 - 11.5 | 111005A23 |

Description

| | |
|-----------------------------------|--------------|
| Exhaust adapter NPT 1½ - 11.5 | 111005A31 |
| Blow off valve replacement kit | EK6525317 |
| Caster kit | 111005A50 |
| Fail safe gear replacement kit | EK6528264 |
| Inlet non return valve repair kit | EK1637009390 |
| Variable speed drive | 111005A60 |
| Variable speed drive | 111005A61 |

Transport and storage

4 Transport and storage

Refer to [Figure: Correct lifting of pump](#). Transport the pump on a pallet or with a crane using both lifting eyes at the top of the pump. Never try to lift the pump on just one lifting eye.

Storage

Store the pump in a dry place, preferably at room temperature. The pump must be sealed with the supplied end caps.

Figure 2. Transportation of the pump

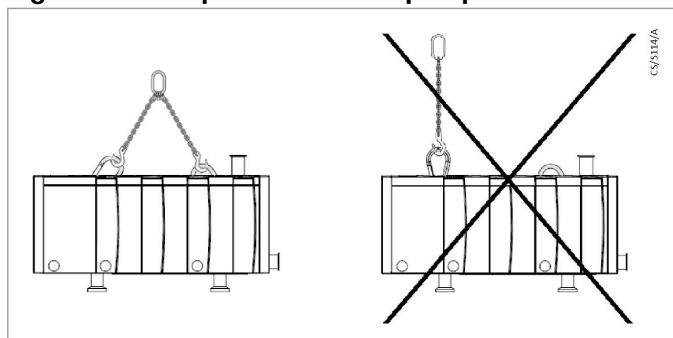

Installation

5 Installation

Figure 3. Connections and controls

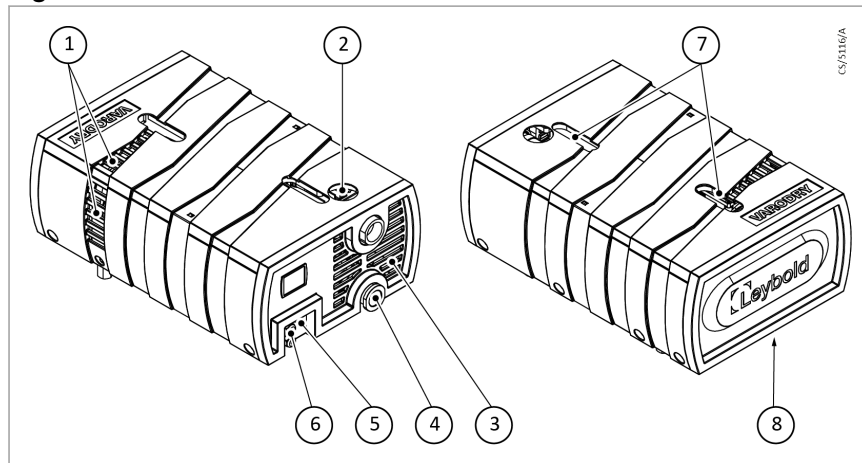

- | | |
|------------------------------|----------------------------|
| 1. Cooling air - out | 2. Inlet flange |
| 3. Cooling air - out | 4. Exhaust flange |
| 5. Purge gas port (optional) | 6. Electrical feedthroughs |
| 7. Lifting eye | 8. Cooling air - in |

5.1 Placement

The cooling air intake and outlets must not have a blockage to prevent insufficient cooling of the pump. Refer to [Figure: Connections and controls](#).

5.2 Conforming use

The pump is designed for use in light and medium industrial applications. The pumps are capable to handle small amounts of dust and liquids, however the use of inlet filters or liquid traps is recommended in such cases. They are not hermetically sealed and will release small amounts of pumped gases to ambient even if the exhaust port is connected to an exhaust pipework. They are suitable for pumping water steam or vapours continuously at a suction pressure range of 0.01 mbar to 1050 mbar as well as for cyclic pump operations within this pressure range.

If you use the pump to handle Oxygen, take note of the following:

- To avoid hazardous oxygen concentrations outside the pump, you must use the seal purge on the exhaust side of the pump. Refer to [Purge gas/Gas ballast connection \(optional\)](#) on page 17.
- The pump must be tightly connected to an exhaust pipework to discharge the pumped gas safely. Make sure that the exhaust pipe is tightly connected to the pump and the exhaust pipework.
- If the amount and concentration of oxygen pumped is considered to be safely discharged directly from the pump (room ventilation is sufficient) the pump can be operated without being connected to an exhaust pipework. The user is responsible to do a risk assessment and decide on the use of exhaust pipework..

5.2.1 Non-conforming use

The pump is not suited for pumping of:

- Radioactive substances
- Explosive substances
- Ignitable gas mixtures
- Pyrophoric gases
- Liquids
- Media in significant amounts condensing in the pump (Except from water)
- Solids
- Corrosive gases
- Toxic gases

5.3 Connect the pump

Remove the caps. We recommend that you retain the caps for decommissioning of the pump.

- During installation work on the intake and discharge lines do not subject flanges to any excessive stresses.

Intake side

- At the intake side, connect the pipework to the vacuum chamber.
- The intake line must be clean. Deposits in the intake line can degas and impair the vacuum. The connecting flanges must be clean and undamaged.

 **Note:**

Do not allow the ingestion of any objects (screws, welding beads, nuts, washers, pieces of wire, etc.) through the intake port of the pump.

Exhaust line



DANGER:

The operator must check, whether the pumped gases will lead to safety risks on the environment if the pump is operated without an exhaust line (i.e. risk of suffocation, risk of slipping due to condensing vapours, etc.).



CAUTION:

Smaller cross sections may cause an undesirable overpressure within the system. Do not start the pump with a constricted or blocked exhaust. Ensure that any valves or blocking devices in the exhaust line are open. Clogged exhaust lines will reduce the available pumping speed, increase temperature and cause overloading of the pump motor or a dangerous overpressure within the system. There is the risk of bursting. The pump can generate pressures up to 1.5 bar (g) at the exhaust, when the discharge line is shut.

- Connect the exhaust line with a hose/pipework to the pump, or when operating the pump without a connected exhaust line, operate the pump only in a well ventilated room.

Installation

- The cross-section of the exhaust line must at least match the inside diameter of the connections.
- When pumping vapours, we recommend connecting a condensate separator at the exhaust. The exhaust lines should be laid so that they drop down and away, thereby preventing condensate from flowing back into the pump.

5.4 Removal of pump cover

In order to access the electrical terminals, the purge gas or gas ballast connections the pump cover has to be removed. To do the pump maintenance, remove only the front cover of the pump.

To remove the pump cover, do the following steps:

1. Allow the pump to cool down in order to avoid receiving burns from hot surfaces underneath the cover.
2. Disconnect the inlet flange from the vacuum system.
3. Remove the four side screws of front pump cover. *Figure: Remove the cover.*
4. Slide the front cover by hand and remove from the pump.
5. Remove the four side screws of back pump cover.
6. Slide the back cover by hand and remove from the pump.

Figure 4. Remove the cover

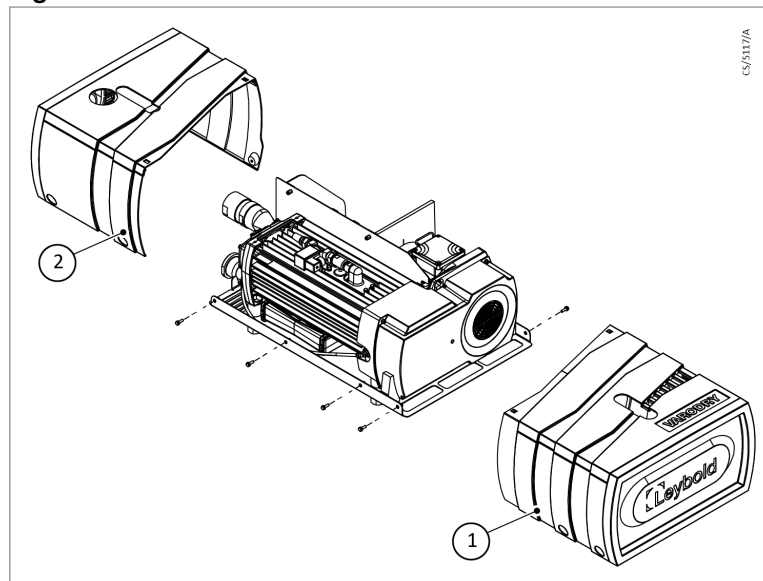

1. Front cover

2. Back cover

5.5 Electrical connection

The pump is supplied with three-phase motor but without accessories for electrical connection. They must be connected with the appropriate cable, and a suitable motor protection switch.

The pump cover must be removed to connect the motor cable.

Set the switch in accordance with the rating on the pump nameplate.

Please observe the diagram inside the motor junction box.

Figure 5. Electrical connection

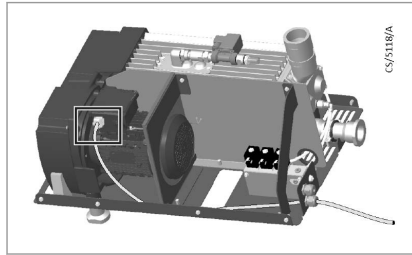

After connecting the motor and after every time you alter the wiring, check the direction of rotation. To do so, briefly switch on the motor and make sure that the pump fan rotates in counter-clockwise direction. If not, interchange two phases of the connection.

An arrow (sticker) indicating the correct direction of rotation is placed on the drive cover. To avoid damage to the pump or the vacuum system make sure that the inlet of the pump is not connected to a closed vacuum system when doing this test. Running the pump at full speed in the wrong direction of rotation will generate pressures up to 4.5 bar (g) at the inlet port, if not vented to atmosphere.

Figure 6. Arrow - direction of rotation

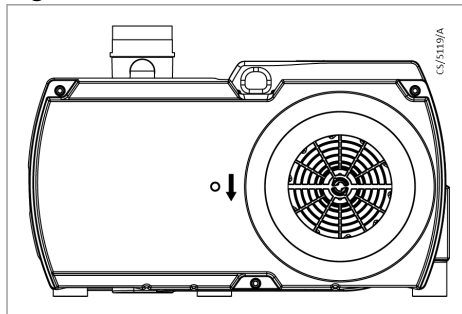

5.6 Optional VFD use

If desired the pumps can be operated via an external variable frequency drive (VFD). However it is not allowed to run the pump with more than the nominal speed. A range of suitable VFDs is available as accessories. Please consult us if other types of VFDs shall be used. The permissible motor speed defined in the [Technical data](#) on page 10 must be obeyed.

Please note that the pump performance and power consumption is not a linear function of motor speed.

5.7 Purge gas/Gas ballast connection (optional)

The pump has a gas ballast system and an optional seal-purge system. It consists of three components.

1. Gas ballast

The pump is equipped with a gas ballast which feeds ambient air into the pump to dilute condensable vapours and keep the partial pressure below the condensation level. The pump water vapour tolerance is 60 mbar. A high vapour tolerance will reduce the vacuum performance of the pump. If the presence of condensable vapours in the pumped gases can be ruled out the gas ballast can be closed. Using the gas ballast will improve the vapour handling but reduce the vacuum performance of the pump.

Installation

2. Seal purge exhaust side (optional)

The pump has no hermetically sealed shaft feedthroughs at the exhaust side. Therefore small amounts of gases inside the pump will escape into the ambient air if no seal purge is used. In order to avoid this the shaft seals at the exhaust side can be loaded with purge gas. The purge gas will create a gas barrier that will prevent gas from inside the pump to escape. Note that a fraction of the purge gas will also escape to the ambient. Make sure that the pump is operated in a room with good ventilation if other gases than air are used as purge gas.
3. Seal purge inlet side

Inlet seal purge can be used if there is a risk that harmful amounts of dust or condensable vapours are present at the inlet of the pump. Such substances could migrate to the inlet side bearings of the pump and reduce the service interval significantly. The inlet side purge is typically only used whenever the inlet pressure increases and is active until a pressure equalisation is reached.

Based on the type, the pump has either a manual gas ballast or 3 solenoid valves for inlet & outlet seal purge and gas ballast mounted underneath the pump enclosure.

5.8 Manual Gas Ballast Configuration

The pump with manual gas ballast (standard version) is delivered with components that can be mounted to the pump body in order to achieve different water vapour tolerances.

When changing the setup, make sure that the gaskets are in good condition and that the parts are tightened properly.

Figure 7. Manual gas ballast configuration

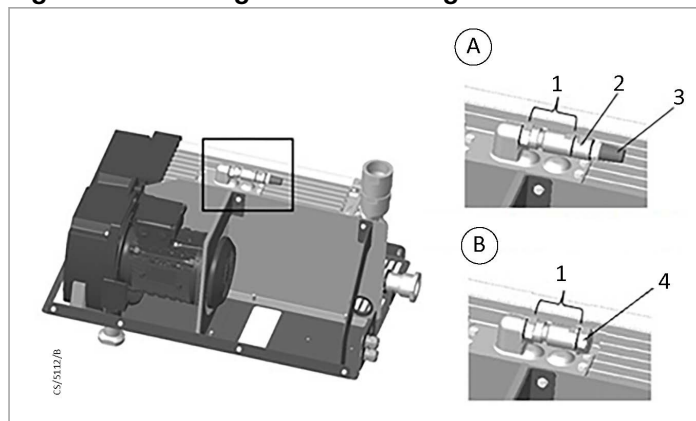

- | | |
|-----------------------------|--------------------------|
| A. Vapour tolerance 60 mbar | B. No gas ballast |
| 1. Non return valve | 2. Nozzle |
| 3. Silencer/Filter | 4. Plug (no gas ballast) |

5.9 Connecting solenoid gas ballast/purge valves

The pump with solenoid valves (optional) has three separate valves as shown in [Figure: Connecting solenoid gas ballast/purge valves](#).

Connect 24 V DC (!) supply voltage to the solenoid valves that will be used in the application. The valves can be activated independently depending on the application requirements.

Figure 8. Connecting solenoid gas ballast/purge valves

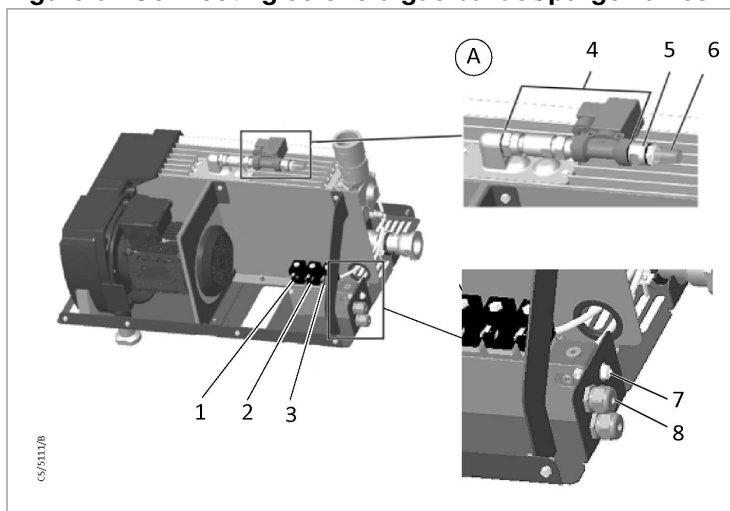

- A. Vapour tolerance 60 mbar
- 1. Exhaust seal purge
- 2. Not used
- 3. Inlet seal purge
- 4. Non return valve
- 5. Nozzle
- 6. Silencer/Filter
- 7. Purge gas port
- 8. Feedback for cables

Operation

6 Operation

Start the pump by applying the supply voltage. The pump can be started up to 20 times per hour.



WARNING:

Connect the pump to an exhaust gas pipework if other gases than clean air are pumped. The exhaust of the pump must not be blocked or constricted. Never operate the pump with the seal-off stoppers in place blanking off the exhaust port.

6.1 Switching off

Switch off the pump by disconnecting from the mains voltage.

If condensable vapours have been conveyed, operate the pump for 30 minutes with closed process valve and open gas-ballast before switching off in order to evaporate the residual condensate.

The pump will run down for several seconds. Due to the design, the vacuum system is then vented through the pump, if no valve is closed between the pump and the vacuum system. In this case, the pump runs backwards until the pressure is equalised. In case of vacuum chambers exceeding a defined volume a valve must be closed before switching off the pump to avoid over-speeding of the pump and contamination of the vacuum system with dust streaming back from the exhaust pipework.

The maximum chamber sizes to be vented through the pump are:

VARODRY VD 65: 500 l

VARODRY VD 100: 800 l

VARODRY VD 160-200: 1000 l

The ventilation process may take several minutes, depending on the size of the container. Wait for the pressure equalisation before opening the vacuum system or disconnecting the pump from the vacuum system.

In order to avoid back-venting of the vacuum chamber close the inlet of the pump with a valve before switching off. A suitable inlet non return valve is available as optional accessory.

Maintenance

7 Maintenance

7.1 Maintenance schedule

The maintenance for the pump includes the following:

1. Belt change
2. Pump overhaul

The belt change can be done by the user of the pump. (See instructions in [Pump Timing Belt Change](#) on page 22).

The pump overhaul requires special equipments and must be done by us.

The pump is equipped with a battery powered hour meter to measure the operation hours. Remove the pump cover to access the hour meter.

The lifetime of the battery is limited to 3-5 years. If the battery is empty the hour meter needs to be replaced. Contact us for hour meter replacement.

| Maintenance | Interval (operation hours) | |
|--|------------------------------------|-------------------------------------|
| | Ambient temperature: 0 °C-30 °C | Ambient temperature: 30 °C-40 °C |
| Belt change | 6000 hours or 25000 start cycles | 4,800 hours or 25000 start cycles |
| Overhaul | 24000 hours | 19200 hours |
| Blow off valve inspection (applications which form deposits only) | 6000 hours | 4800 hours |

Maintenance

7.2 Tools required for maintenance

Figure 9. Tools required for maintenance

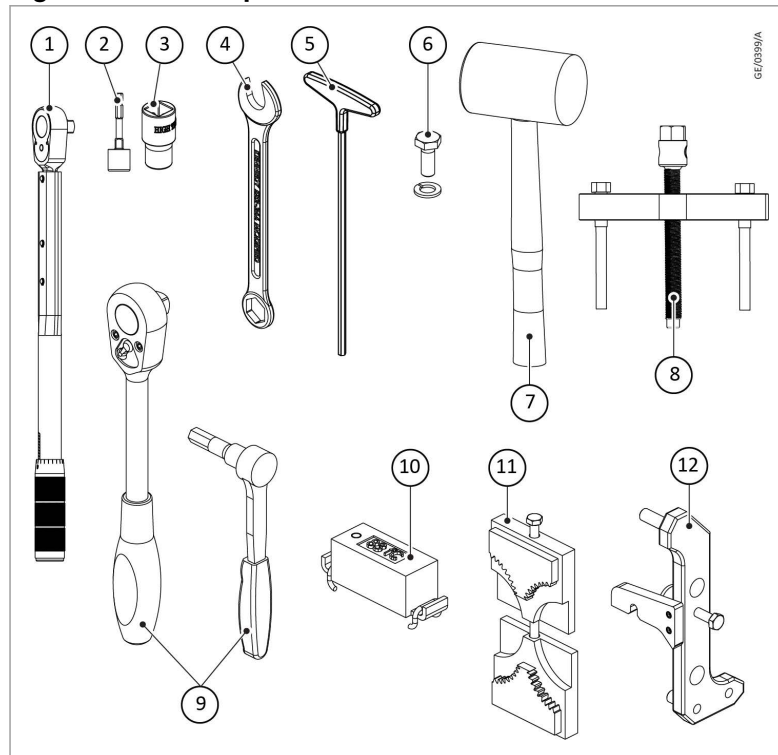

| Sr No. | Description | Quantity |
|---|-------------------------------------|----------|
| 1 | Torque wrench | 1 |
| 2 | Allen key socket No.6 | 1 |
| 3 | Socket wrench insert 22 | 1 |
| 4 | Wrench 12 | 1 |
| 5 | Allen key T handle 5 | 1 |
| 6 | M8 hex screw | 1 |
| 7 | Mallet | 1 |
| 8 | Pulling device | 1 |
| 9 | Ratchet | 1 |
| Special tool kit for belt replacement (EK6530942) | | |
| 10 | Tool for belt tension measurement | 1 |
| 11 | Equipment fail safe gear adjustment | 1 |
| 12 | Tool for belt tension adjustment | 1 |

7.3 Pump timing belt change

The pump timing belt is subjected to wear and must be replaced after a defined operation period (see [Maintenance schedule](#) on page 21). The belt exchange can be either performed by us or by the pump user.

Accessories required:

- Replacement timing belt
 - 50 Hz Versions: EK6528531
 - 60 Hz Versions: EK6528533

Refer to [Tools required for maintenance](#) on page 22 for more details.

7.4 Replace the belt

CAUTION:



Obey the safety regulations. Make sure that the main power source is disconnected and all parts with electric supply are covered or closed.

Make sure that there is no pressure difference between inlet and outlet of the pump during the belt change as the pressure difference will force the pump to rotate. If this can not be ruled out disconnect the pump from the vacuum system before changing the belt.



CAUTION:

Loosening the hexagon nuts of rotors will cause severe bearing damages.

7.4.1 Disassemble drive enclosure

1. Use a 5 mm Allen key to remove the 3 screws which secure the drive enclosure.
2. Separate the drive enclosure from the pump.
3. Remove the foam by hand.

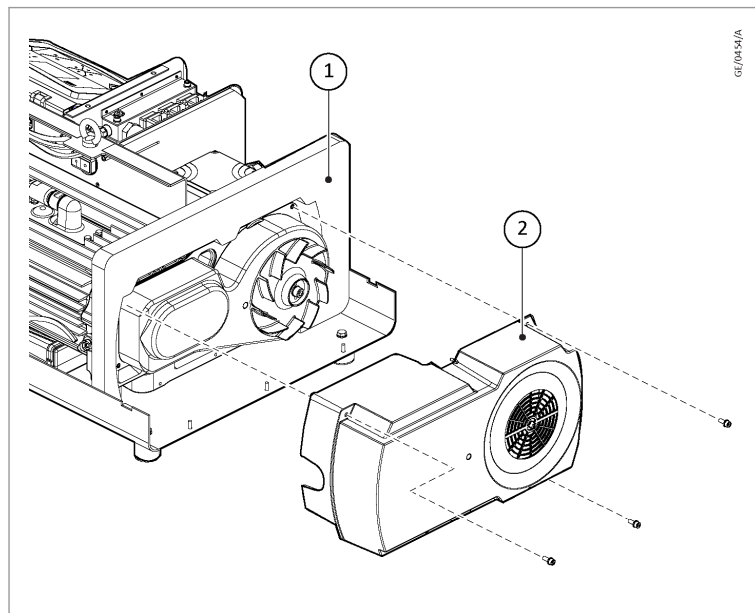

1. Foam

2. Drive enclosure

Maintenance

7.4.2 Disassemble rotor disc, screw and fan

1. Use a 8 mm Allen key to remove the screws, washer and rotor washer which secure the fan on the belt chamber.
2. Separate the fan from the pump.

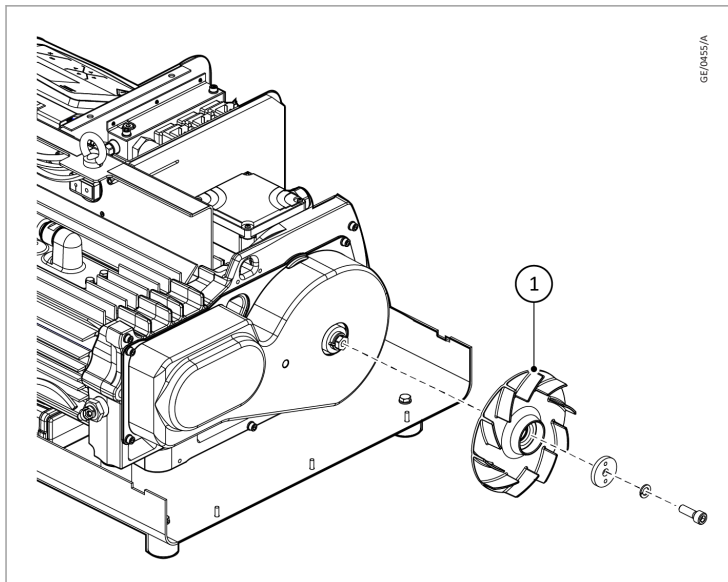

1. Fan

7.4.3 Disassemble belt chamber cover

1. Use a 5 mm Allen key to remove the 4 screws which secure the belt chamber cover.
2. Separate the belt chamber cover from the pump.

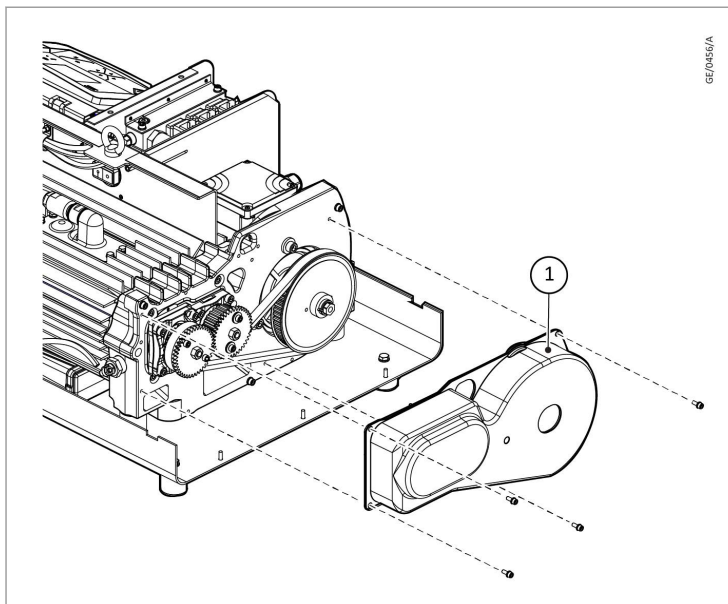

1. Belt chamber cover

7.4.4 Disassemble fail safe gears

1. Use the fail safe gear adjustment tool to interlock the rotors.

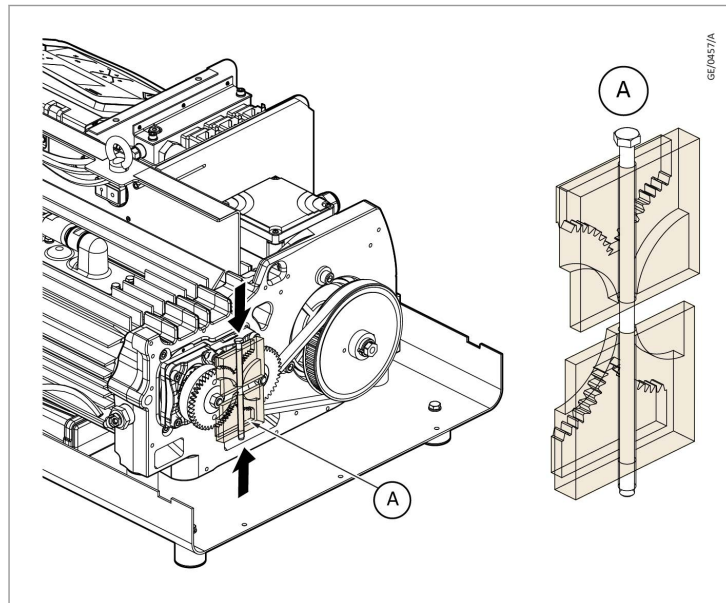

2. Loosen the 4 bolts by 1 rotation with a 5 mm Allen key and remove the bolts.

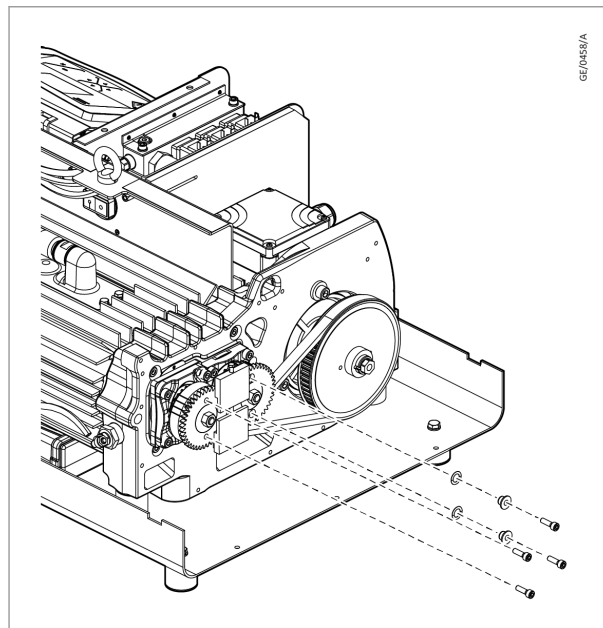

3. Remove the gear adjustment tool.

Maintenance

4. Remove the bushing, o-ring and fail-safe gears.

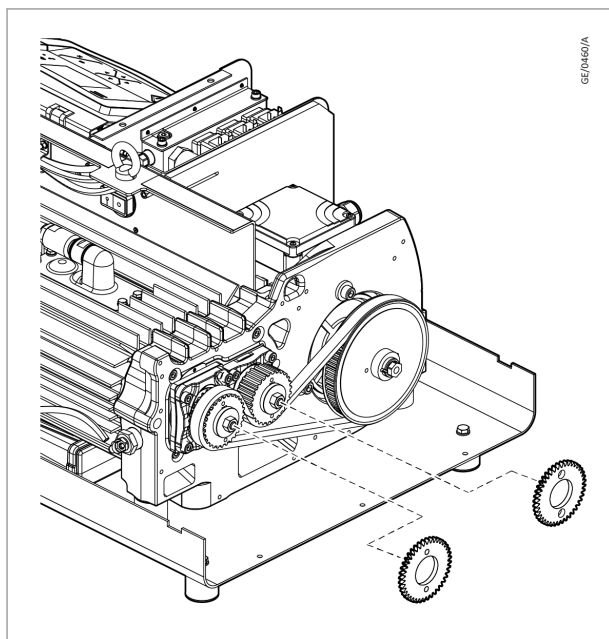

7.4.5 Disassemble belt

1. To enable belt removal, use a 8 mm Allen key to loosen the 4 screws which secure the motor and pulley to the bearing flange.

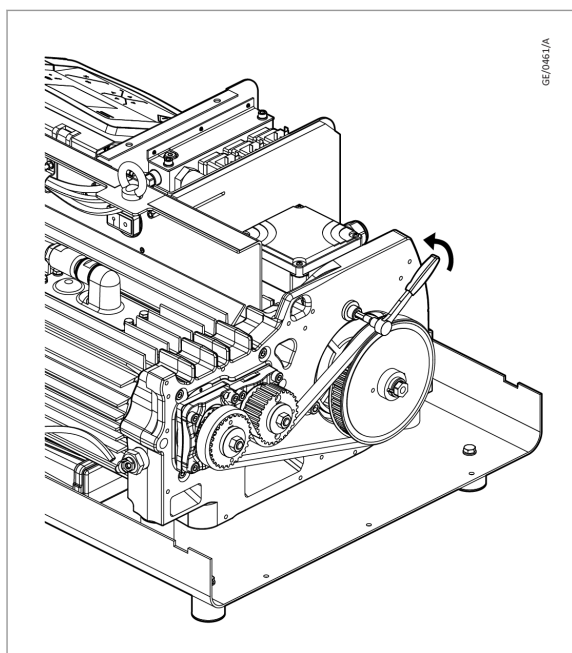

Maintenance

2. Push the motor towards the pump body to loosen the belt.

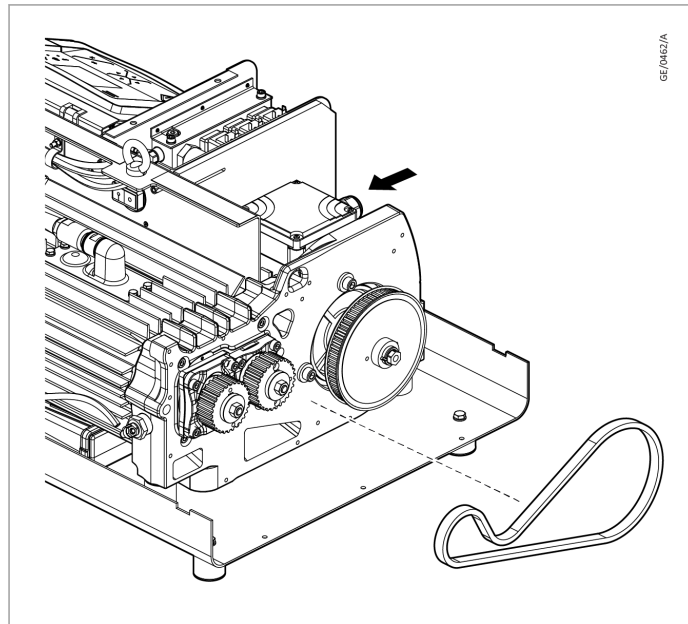

3. Take the belt out of gears and pulley.
4. Clean the gears and pulley with recommended cleaning agent.
5. Dispose of the old belt.

7.4.6 Assemble tooth belt

1. Place the belt on the timing gears.
2. Install the belt tighten tool and attach the VSM mini on the belt. Switch on the VSM mini.
3. Tighten the belt with a 19 mm wrench (for belt tighten tool). Tap the belt slightly and measure the frequency (Hz). Make sure that the frequency is 83 ± 5 Hz. Tap the belt 5 to 8 times to check the frequency.
4. Remove the VSM mini and the belt tightening tool.

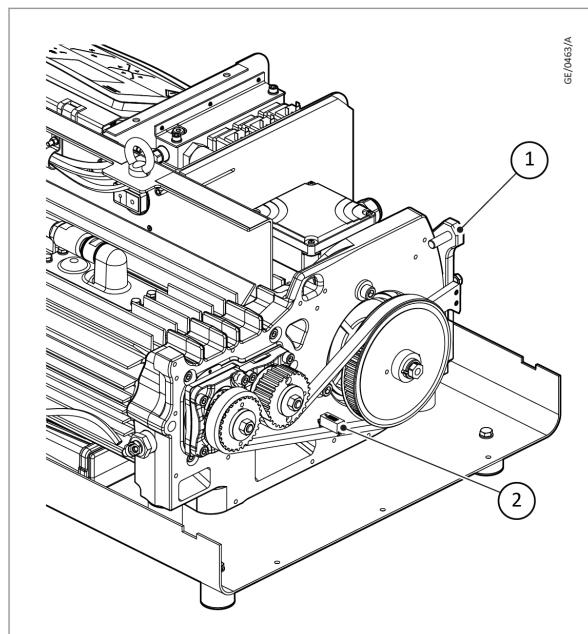

Maintenance

1. *Belt tightening tool*
2. *VSM mini*

7.4.7 Assemble motor screw

1. Tighten the motor cap screw with a 8 mm Allen key. Torque each screw in cross pattern to 40 Nm.
2. Rotate the pulley by hand for 5 to 8 times and make sure that the belt is tightened and running correctly.
3. Attach the VSM mini on the belt
4. Tap the belt slightly and measure the frequency (Hz).
5. Make sure that the frequency is 83 ± 5 Hz. If the belt tension is not within range, unscrew the motor cap and repeat steps in [Assemble tooth belt](#) on page 27 and steps 1-5 in this section.
6. Remove the VSM mini

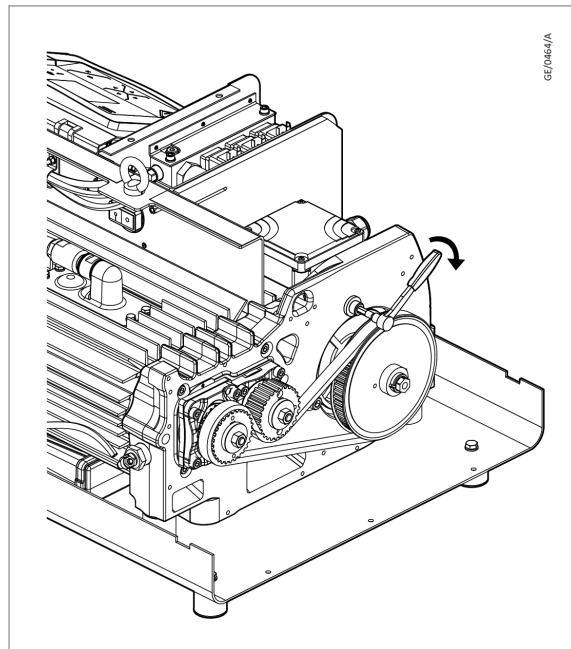

7.4.8 Assemble fail safe gear

1. Replace and assemble the fail-safe gear and all necessary parts back to original position in reverse order of disassembly.
2. Place the bolts for fastening the gears.

Maintenance

3. Tighten the plastic gear with 2 bolts to 10 Nm.

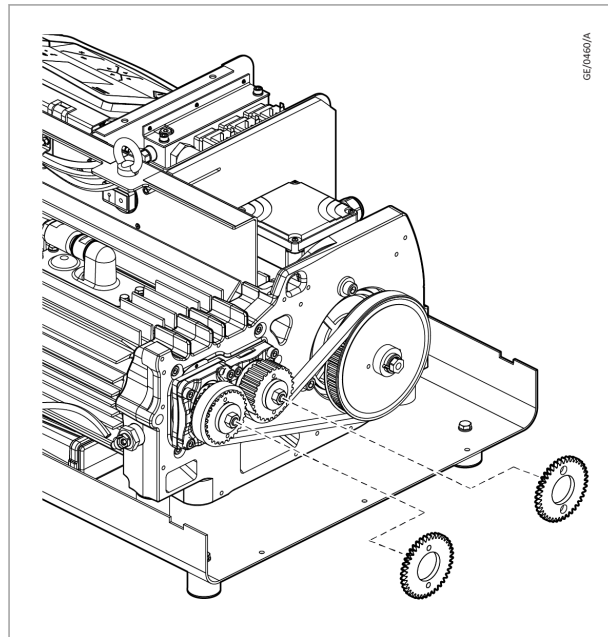

4. Rotate the motor pulley by hand for 5 to 8 revolutions in counter-clockwise direction. Do not turn clockwise, until the fail-safe gears are fastened.
5. Place the gear adjustment tool on gears and fasten it. Avoid clockwise rotation of belt.

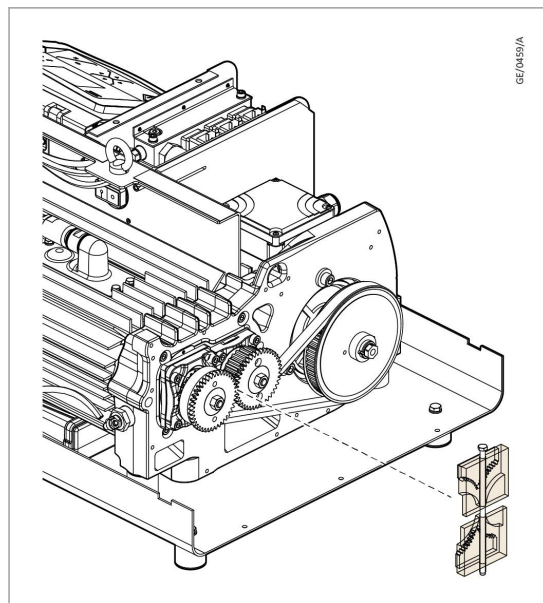

Maintenance

6. Tighten the steel gear with 2 bolts to 10 Nm.

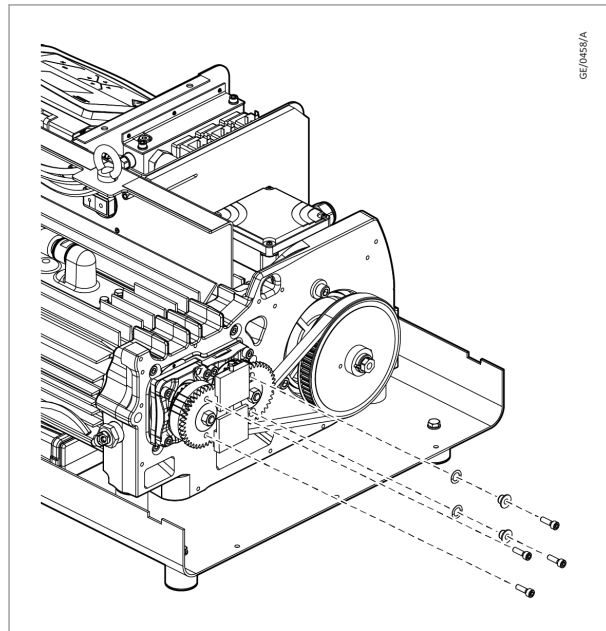

7. Remove the gear adjustment tool.
8. Rotate the motor pulley in counter clockwise direction by hand for three revolutions.
9. Make sure that the gears do not touch. If the gears touch, repeat step 5 to step 8.

7.4.9 Assemble belt chamber cover

1. Assemble the belt chamber cover onto the bearing flange with 4 cap screws with a 5 mm Allen key.
2. Tighten the cap screws by hand and torque each screw to 2.5 Nm.

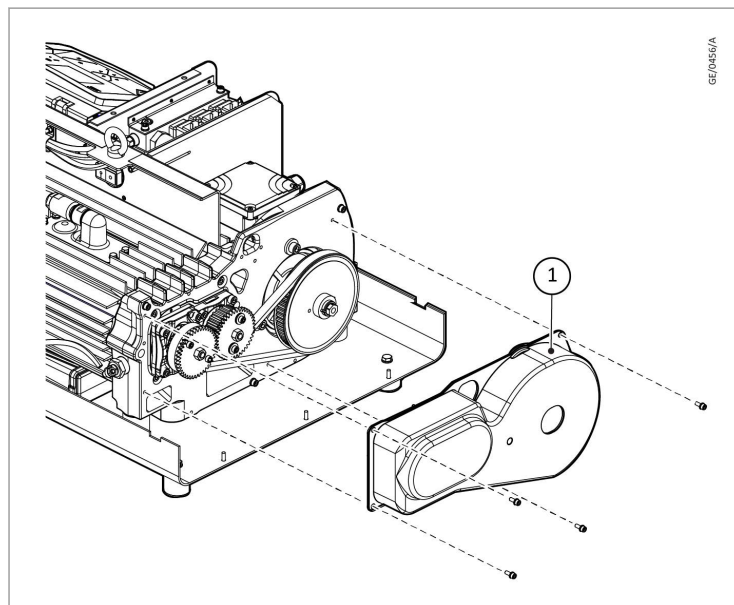

1. *Belt chamber cover*

7.4.10 Assemble fan

1. Assemble the fan with a 8 mm Allen key.
2. Tighten the cap screw by hand and torque screw to 20 Nm after locking the fan by spanner.

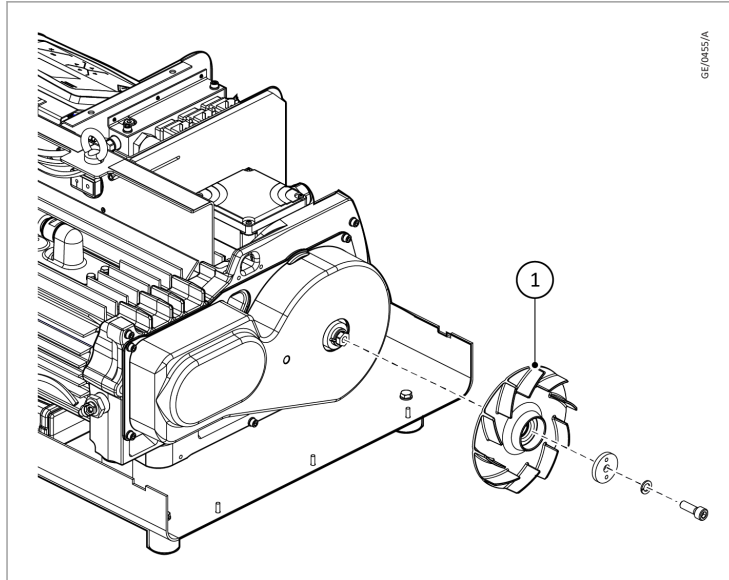

1. Fan

7.4.11 Assemble drive enclosure

1. Put the foam in place on the pump.
2. Assemble the drive enclosure onto the bearing flange with 3 cap screws with a 5 mm Allen key.
3. Tighten the cap screws by hand and torque each screw to 2.5 Nm.

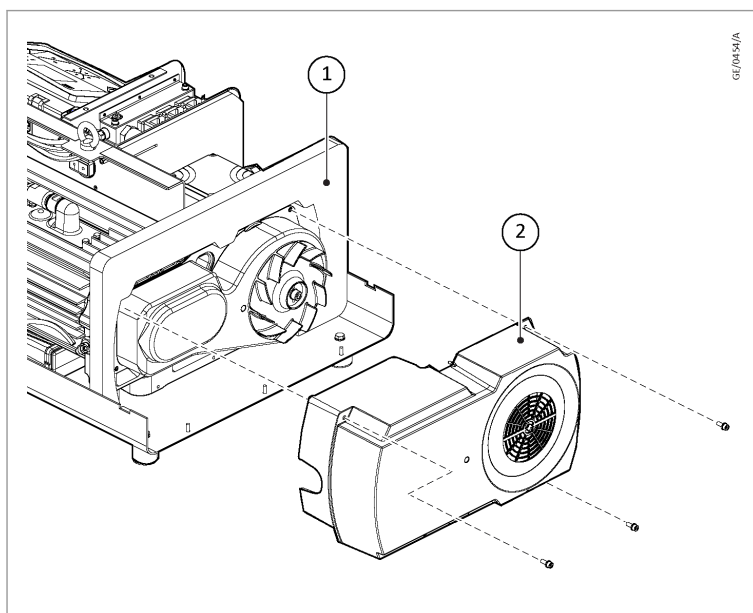

1. Foam

2. Drive enclosure

Maintenance

7.4.12 Electric connection

1. Open the motor terminal box.
2. Do the electrical connection before you install the enclosure. Refer to the pump manual for instruction.
3. Connect the cables and make sure that it is away from the hot surfaces of the pump.

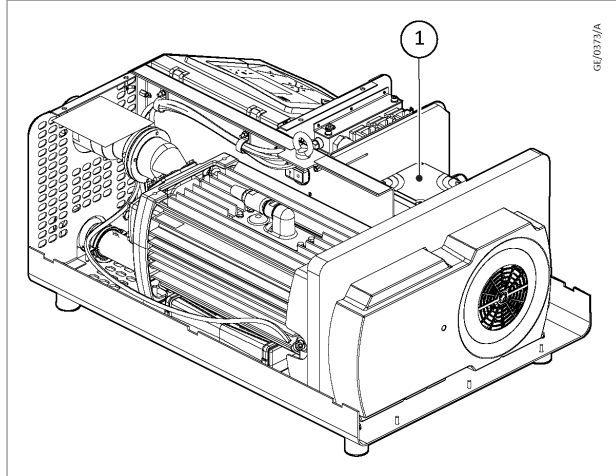

1. Motor terminal box

7.4.13 Verify motor rotation



WARNING:

Do not close the pump inlet with your hands or any other body part and avoid objects from being sucked inside the pump.

To verify the correct rotating direction of the motor, start the pump and check that

- the pump fan rotates in the same direction as the arrows on the fan protection grille.

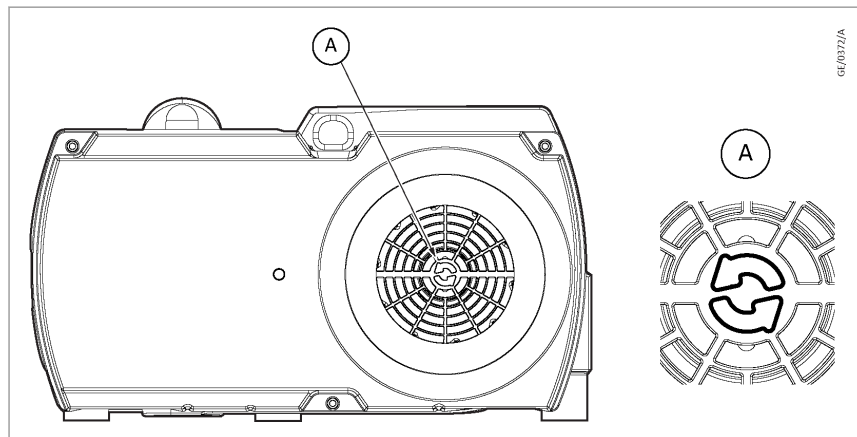

- the pump creates vacuum on the inlet port.

In case of wrong direction, swap the two phases at the motor clamping board.

7.5 Blow off valve cleaning



CAUTION:

Obey the safety regulations. Make sure that the main power source is disconnected and all parts with electric supply are covered or closed. As there will be exposure to the pumped substances, use appropriate PPE such as rubber gloves depending on the substances that are present in the process.

Accessories required to clean the blow off valve:

- Spanner: 10 mm
- Lint free cloth for cleaning
- Water or isopropanol for cleaning

To clean the blow off valve:

1. Remove the 4 x M6 screws (1) of the blow off cover (2).
2. Pull the blow off cover (2) up gently.
3. Remove the valve ball (3).
4. Check all surfaces for contamination. If required, clean with water or isopropanol.
5. Check the valve ball and all O-rings for damage or wear, replace if necessary (EK6525317).
6. Reassemble the components (a missing valve ball will destroy the pump).
7. Tighten the 4 x M10 screws with 8 Nm.

Maintenance

Figure 10. Blow off valve cleaning

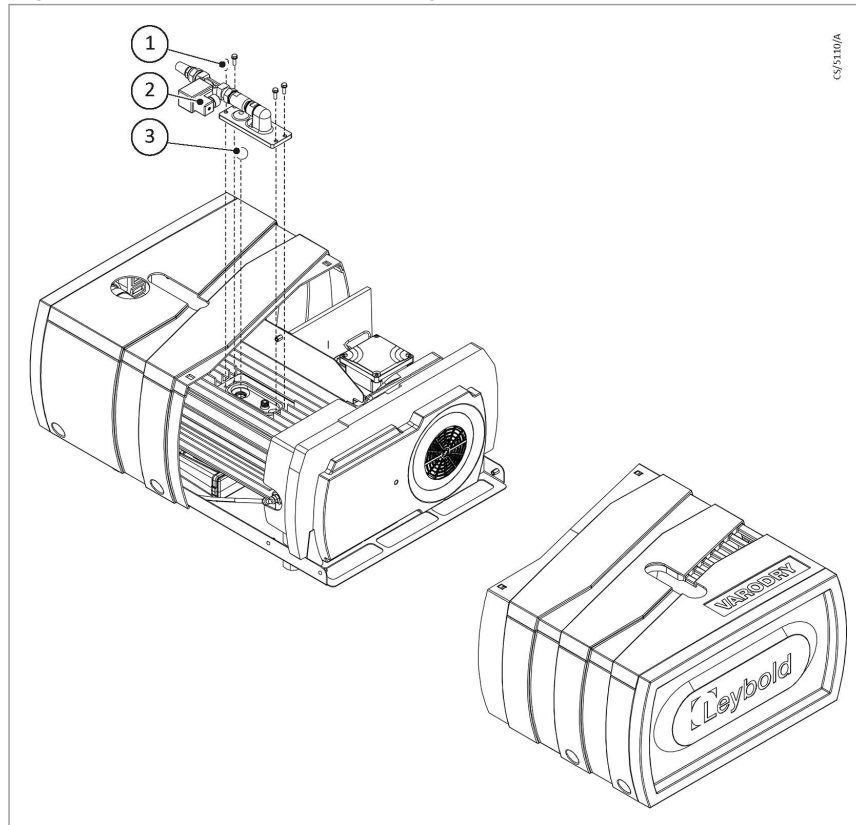

1. Screws
2. Blow off cover
3. Ball valve

Note:

VD 160/200 have two ball valves.

7.6 Replace electrical motor

7.6.1 Motor disassembly

To replace the electric motor, do the steps that follow:

1. Remove the fan cover (1).

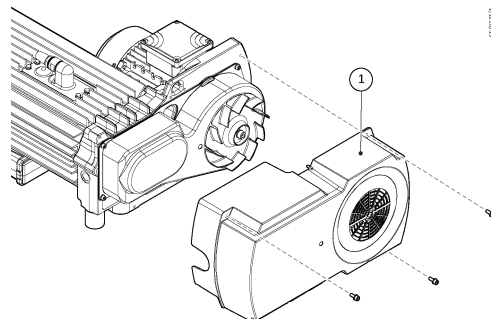

Maintenance

2. Remove the fan (2).

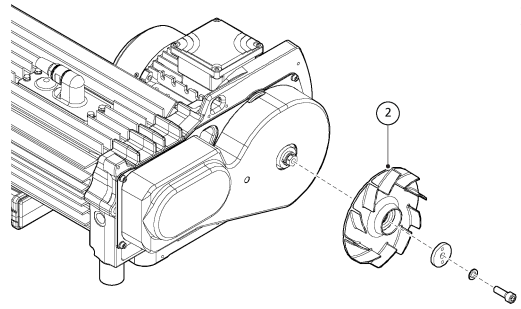

3. Remove the belt enclosure (3).

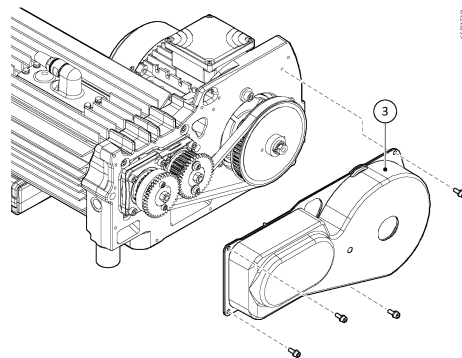

4. Block the fail safe gears with the gear adjustment tool (A).

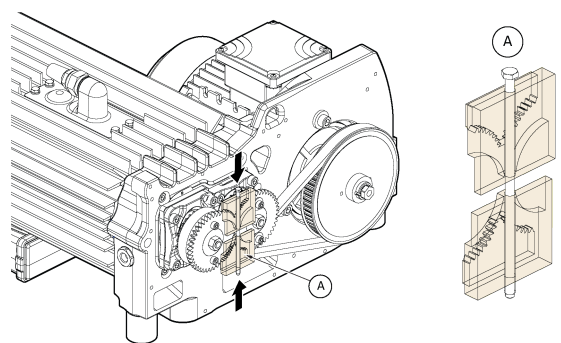

5. Loosen the centre screw.

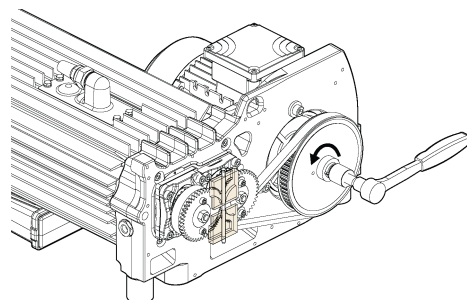

Maintenance

6. Loosen and remove the bolts of fail safe gears.

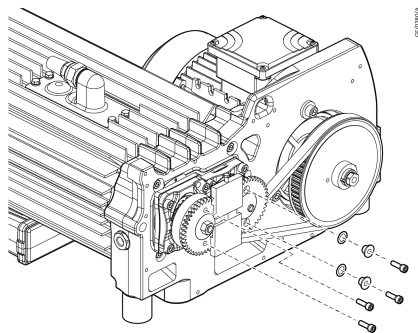

7. Remove the gear fixation tool.

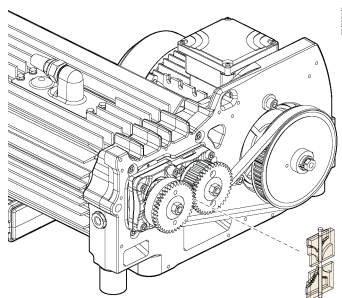

8. Remove the fail safe gears.

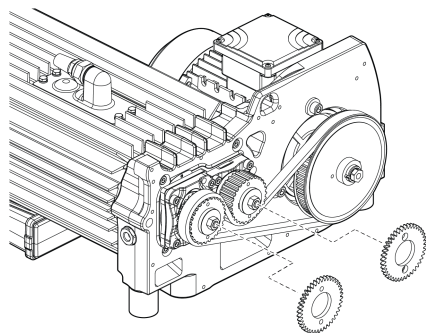

9. Remove the 4 motor screws.

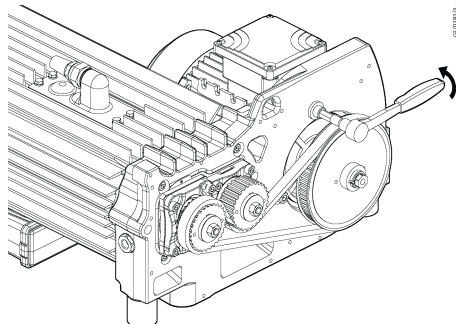

Maintenance

10. Push the motor gently and pull out the belt.

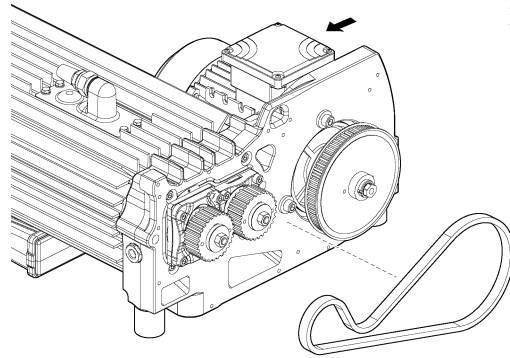

11. Remove the centre screw.

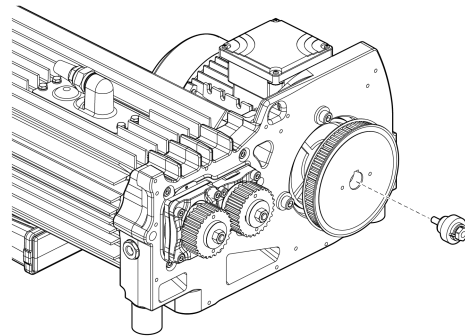

12. Install the M8 hexagonal bolt and washer.

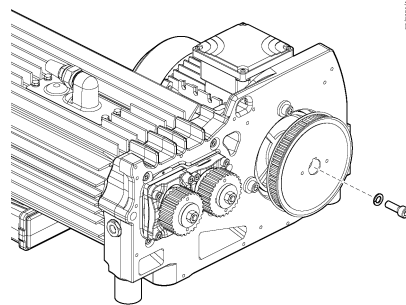

13. Install the gear puller into the middle of the pulley.

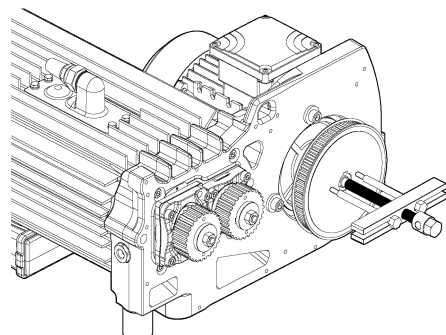

Maintenance

14. Remove the pulley with the gear puller tool.

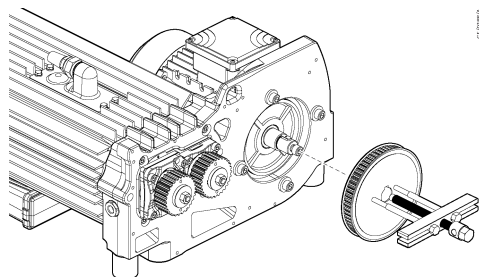

15. Unscrew the 4 motor screws.

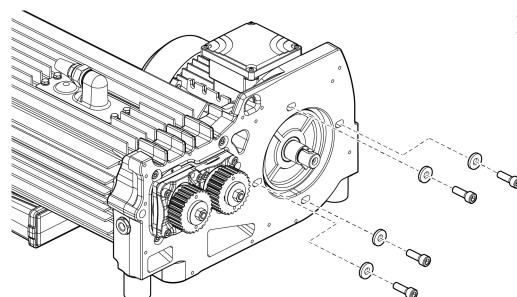

16. Remove the motor.

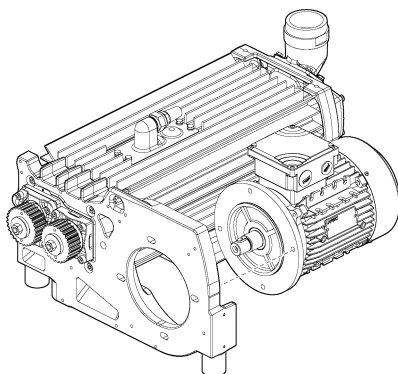

7.6.2 Motor assembly

1. Place the new motor for installation.

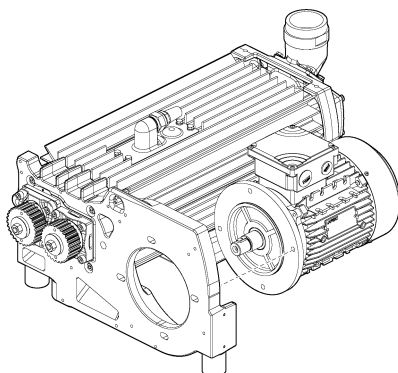

Maintenance

2. Install the 4 motor screws and hand tighten.

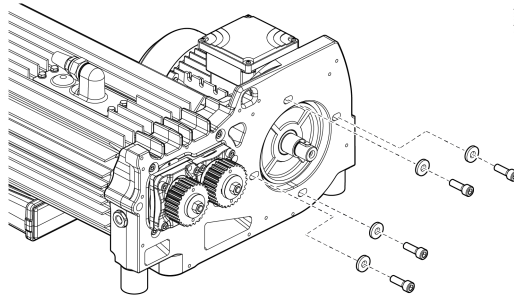

3. Install the pulley to the motor.

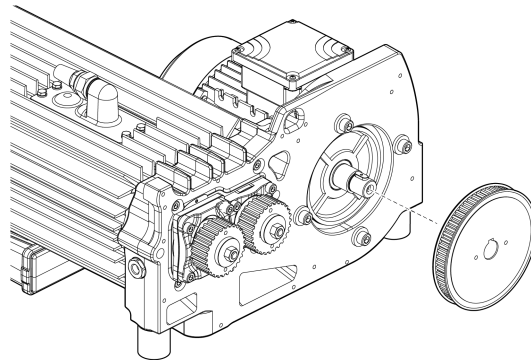

4. Make sure that the key (1) and keyway are aligned correctly.

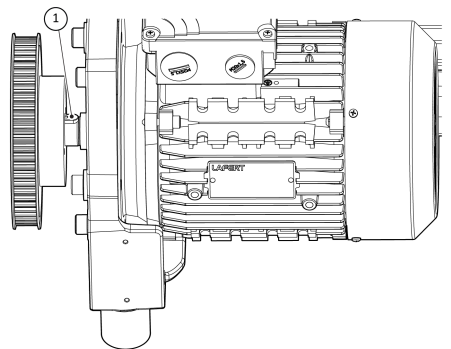

5. Tap the pulley with a mallet gently to push the pulley.

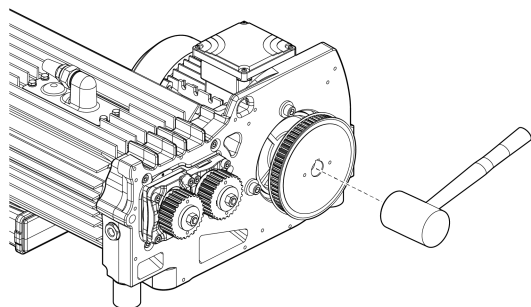

Maintenance

6. Insert the centre screw and hand tighten.

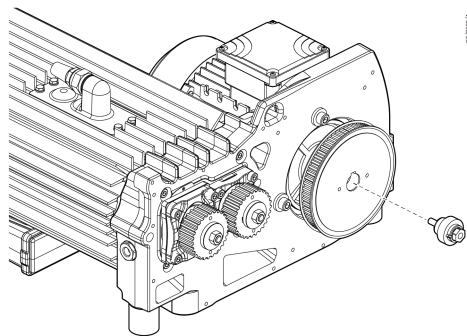

7. Install the belt gears.

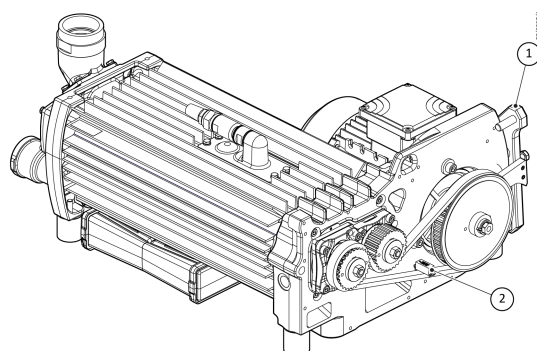

8. Tighten the motor screws.

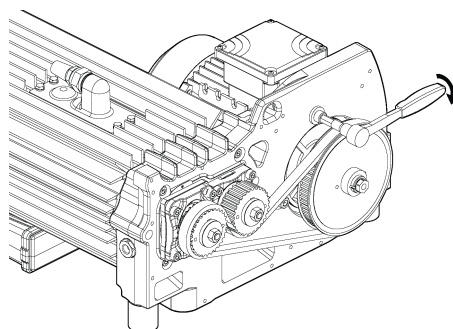

9. Replace and assemble the fail-safe gear.

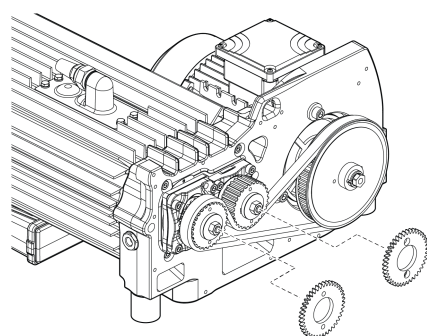

Maintenance

10. Install the gear adjustment tool on the fail safe gears.

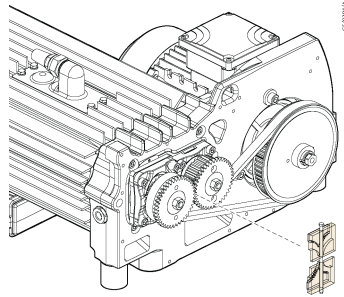

11. Assemble the fail safe gears bolts.

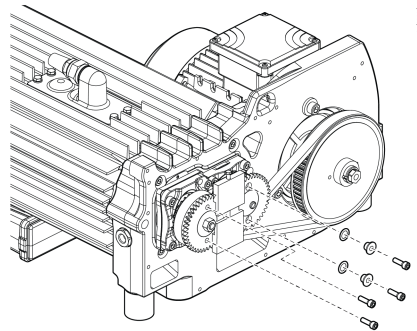

12. Fix the centre nut. Use a torque wrench to tighten the screw to 25 Nm.

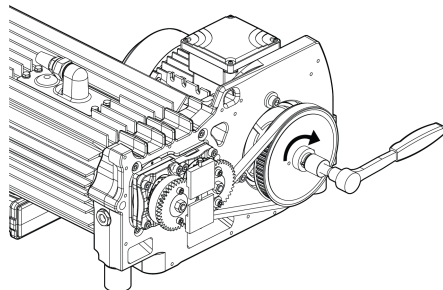

13. Install the belt enclosure (3).

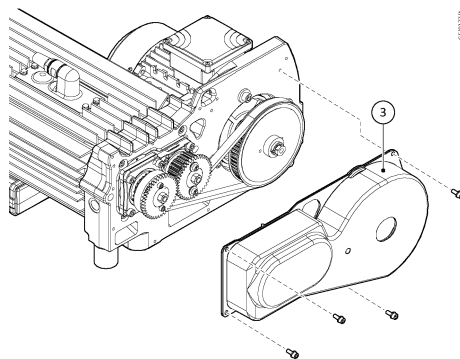

Maintenance

14. Install the fan (2).

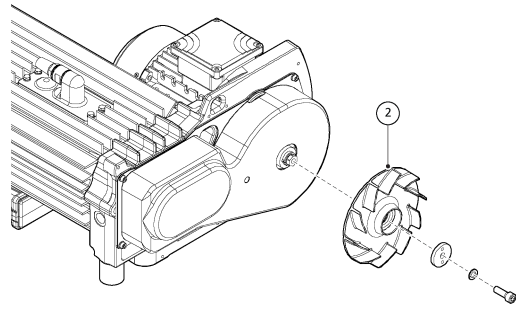

15. Install the fan cover (1).

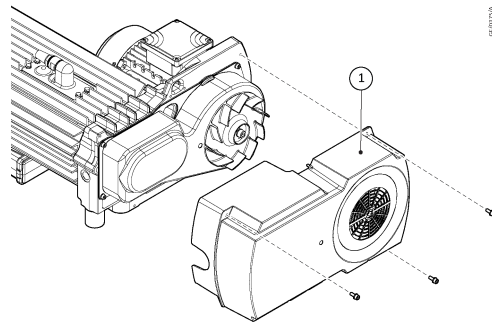

7.7 Table: Motor part list

Table 3 Motor part list

| Product name | Motor spare part no. | | | | | | | |
|--|----------------------|----------|----------|----------|----------|----------|----------|----------|
| | E6524957 | E6537817 | E6524959 | E6537818 | E6524971 | E6537819 | E6524973 | E6537850 |
| VARODRY VD 65, 50 Hz | • | | | | | | | |
| VARODRY VD 65, 60 Hz | • | | | | | | | |
| VARODRY VD 65, 50 Hz, Purge | • | | | | | | | |
| VARODRY VD 65, 60 Hz, Purge | • | | | | | | | |
| VARODRY VD 65, 200/380 V 60 Hz | | • | | | | | | |
| VARODRY VD 65, 200/380 V 60 Hz, Purge | | • | | | | | | |
| VARODRY VD 100, 50 Hz | | | • | | | | | |
| VARODRY VD 100, 60 Hz | | | • | | | | | |
| VARODRY VD 100, 50 Hz, Purge | | | • | | | | | |
| VARODRY VD 100, 60 Hz, Purge | | | • | | | | | |
| VARODRY VD 100, 200/380 V 60 Hz | | | | • | | | | |
| VARODRY VD 100, 200/380 V 60 Hz, Purge | | | | • | | | | |
| VARODRY VD 160, 50 Hz | | | | | • | | | |
| VARODRY VD 160, 60 Hz | | | | | • | | | |
| VARODRY VD 160, 50 Hz, Purge | | | | | • | | | |
| VARODRY VD 160, 60 Hz, Purge | | | | | • | | | |
| VARODRY VD 160, 200/380 V 60 Hz | | | | | | • | | |

Maintenance

| Product name | Motor spare part no. | | | | | | | |
|--|----------------------|----------|----------|----------|----------|----------|----------|----------|
| | E6524957 | E6537817 | E6524959 | E6537818 | E6524971 | E6537819 | E6524973 | E6537850 |
| VARODRY VD 160, 200/380 V 60 Hz, Purge | | | | | | • | | |
| VARODRY VD 200, 50 Hz | | | | | | | • | |
| VARODRY VD 200, 60 Hz | | | | | | | • | |
| VARODRY VD 200, 50 Hz, Purge | | | | | | | • | |
| VARODRY VD 200, 60 Hz, Purge | | | | | | | • | |
| VARODRY VD 200, 200/380 V 60 Hz | | | | | | | | • |
| VARODRY VD 200, 200/380 V 60 Hz, Purge | | | | | | | | • |
| VARODRY VD 65 HD/O ₂ , 50 Hz, 200/400 V, Purge | • | | | | | | | |
| VARODRY VD 65 HD/O ₂ , 60 Hz, 230/460 V, Purge | • | | | | | | | |
| VARODRY VD 65 HD/O ₂ , 60 Hz, 200/380 V, Purge | | • | | | | | | |
| VARODRY VD 100 HD/O ₂ , 50 Hz, 200/400 V, Purge | | | • | | | | | |
| VARODRY VD 100 HD/O ₂ , 60 Hz, 230/460 V, Purge | | | • | | | | | |
| VARODRY VD 100 HD/O ₂ , 60 Hz, 200/380 V, Purge | | | | • | | | | |
| VARODRY VD 160 HD/O ₂ , 50 Hz, 200/400 V, Purge | | | | | • | | | |
| VARODRY VD 160 HD/O ₂ , 60 Hz, 230/460 V, Purge | | | | | • | | | |
| VARODRY VD 160 HD/O ₂ , 60 Hz, 200/380 V, Purge | | | | | | • | | |
| VARODRY VD 200 HD/O ₂ , 50 Hz, 200/400 V, Purge | | | | | | | • | |
| VARODRY VD 200 HD/O ₂ , 60 Hz, 230/460 V, Purge | | | | | | | • | |
| VARODRY VD 200 HD/O ₂ , 60 Hz, 200/380 V, Purge | | | | | | | | • |

Troubleshooting

8 Troubleshooting

| Fault | Pump does not start up |
|--------------|---|
| Cause | Wrong or loose connection at motor terminal |
| Remedy | Check the connections |
| Cause | Pump is blocked |
| Remedy | Contact us |
| Cause | Belt is broken |
| Remedy | Contact us |
| Cause | Motor is defective |
| Remedy | Contact us |
| Cause | Wrong supply voltage |
| Remedy | Check the mains power or inverter |
| Fault | Motor protective switch triggers |
| Cause | Pump is blocked |
| Remedy | Contact us |
| Cause | Motor is defective |
| Remedy | Contact us |
| Cause | Wrong setting of protective switch |
| Remedy | Adjust the setting. Refer to Technical data on page 10. |
| Cause | Wrong direction of rotation |
| Remedy | Check and change the direction of rotation if applicable |
| Cause | Wrong supply voltage |
| Remedy | Check the mains power |
| Cause | Exhaust line is clogged |
| Remedy | Clean the exhaust line |
| Fault | Pump does not reach vacuum performance |
| Cause | Inlet filter is clogged |
| Remedy | Clean the inlet filter (if in use) |
| Cause | Gas leak at the pump inlet |
| Remedy | Check O-ring at inlet port or connections of accessories |
| Cause | Wrong rotational speed |
| Remedy | Check the mains frequency or inverter |

Troubleshooting

| | |
|--------------|--|
| Cause | Wrong setting of gas ballast |
| Remedy | Correct if applicable |
| Cause | Inlet seal purge is defective |
| Remedy | Contact us |
| Cause | Loose gas ballast connection |
| Remedy | Check tight fit of gas ballast parts |
| Cause | Cold pump |
| Remedy | Wait for 30 minutes to warm-up the pump |
| Cause | Wrong voltage wiring |
| Remedy | Check with drawing in the motor connection box |
| Cause | Wrong position or type of vacuum gauge |
| Remedy | Check pressure direct at the inlet port. We recommend type TTR or CTR 0.1 torr |
| Cause | Purge connection is loose |
| Remedy | Tighten the purge connection and check tight fit of hose |

| | |
|--------------|--|
| Fault | Pump is noisy or has high vibration level |
| Cause | Pump is clogged with process deposition |
| Remedy | Follow the cleaning instructions |
| Cause | Belt is worn or defective |
| Remedy | Exchange the belt Contact us |
| Cause | Bearing is defective |
| Remedy | Contact us |

Disposal

9 Disposal

9.1 Waste disposal

DIRECTIVE 2012/19/EU OF THE EUROPEAN PARLIAMENT AND OF THE COUNCIL on waste electrical and electronic equipment (WEEE)

This equipment falls under the provisions of the European Directive 2012/19/EU on waste electrical and electronic appliances (WEEE) and may not be disposed as unsorted waste.



The equipment is labelled in accordance with the European Directive 2012/19/EU with the crossed-out wheellie bin symbol.

At the end of life-time of the electric and electronic equipment (EEE) it must be taken to separate collection.

For more information check with your local waste authority, customer center or distributor.

The pump may have been contaminated by the process or by environmental influences. In this case the equipment must be decontaminated in accordance with the relevant regulations. We offer this service at fixed prices. Further details are available on request.



WARNING:

Contaminated parts can be detrimental to health and environment. Before beginning with any work, first find out whether any parts are contaminated. Adhere to the relevant regulations and take the necessary precautions when handling contaminated parts.

Separate clean pumps according to their materials, and dispose of these accordingly. We offer this service. Further details are available on request.

When sending us a pump, observe the regulations given in [Leybold Service](#) on page 47.

10 Leybold Service

Whenever you send us equipment, indicate whether the equipment is contaminated or is free of substances which could pose a health hazard. If it is contaminated, specify exactly which substances are involved. You must use the form we have prepared for this purpose.

The form Declaration of Contamination for Compressors, Vacuum Pumps and Components is available on www.leybold.com-> [Downloads](#) -> [Download Documents](#).

Attach the form to each pump. This statement detailing the type of contamination is required to satisfy legal requirements and for the protection of our employees.

We will return to the sender any equipment which is not accompanied by a contamination statement.



EU Declaration of Conformity

(Translation of original Declaration of Conformity)

The manufacturer: Leybold GmbH
Bonner Strasse 498
D-50968 Köln
Germany

herewith declares that the products specified and listed below which we have placed on the market, comply with the applicable EU Directives. This declaration becomes invalid if modifications are made to the product without agreement of Leybold GmbH.

Product designation: Fore vacuum pump
Type designation: VARODRY VD 65-200
Part numbers: 111065V..., 111100V..., 111160V..., 111200V...

The products comply to the following directives:

Machinery Directive (2006/42/EC)

The safety objectives of the Low Voltage Directive 2014/35/EU were complied with in accordance with Appendix 1 No. 1.5.1 of Machinery Directive 2006/42/EC.

Electromagnetic Compatibility (2014/30/EU)

Directive RoHS (2011/65/EU) & (2015/863/EU)

The following harmonized standards have been applied:

| | |
|---------------------------|---|
| EN 1012-2:1996+A1:2009 | Compressors and vacuum pumps - Safety requirements Part 2: Vacuum pumps |
| EN 60204-1:2006 | Safety of machinery - Electrical equipment of machines Part1: General requirements |
| EN 61000-6-2:2005/AC:2005 | Electromagnetic compatibility (EMC) - Part 6-2: Generic standards - Immunity for industrial environments |
| EN 61000-6-4:2007/A1:2011 | Electromagnetic compatibility (EMC) - Part 6-4: Generic standards - Emission standard for industrial environments |
| EN 50581:2012 | Technical documentation for the assessment of electrical and electronic products with respect to the restriction of hazardous substances |

Documentation officer: Herbert Etges
T: +49(0)221 347 0
F: +49(0)221 347 1250
documentation@leybold.com

Cologne, September 12th, 2019

Cologne, September 12th, 2019

Andries Desiron
Vice President Engineering
Atlas Copco Industrial Vacuum Division

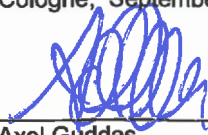
Axel Guddas
General Manager
Leybold GmbH

This page has been intentionally left blank.

This page has been intentionally left blank.

This page has been intentionally left blank.



Pioneering products. Passionately applied.

Leybold GmbH
Bonner Strasse 498
50968 Cologne
GERMANY
+49-(0)221-347-0
info@leybold.com
www.leybold.com