

SURFACE FINISH SYMBOLS

ROUGHNESS SYMBOL

MACHINING DEVIATION FOR OPEN DIMS: IS 2102(Medium)

ALL DIMENSIONS ARE IN mm UNLESS OTHERWISE SPECIFIED.

26	VARIABLE FREQUENCY DRIVE (VFD) #	1
25	DRIVE COUPLING	1
24	FAN WITH MOTOR	2
23	AIR OUT LET VALVE	1
22	PRESSURE TRANSMITTER	1
21	AUTO DRAIN VALVE	1
20	BALL VALVE	1
19	MOISTURE SEPARATOR	1
17	MINIMUM PRESSURE VALVE	1
16	BLOW DOWN VALVE ( NO)	1
15	SOLENOID VALVE ( NC)	1
14	OIL FILTER	1
13&18	COMBI OIL AND AFTER COOLER	1
12	THERMOSTATIC VALVE	1
11	ORIFICE	1
10	AIR OIL SEPARATOR ELEMENT	1
9	SAFETY VALVE	1
8	OIL DRAIN	1
7	AIR OIL SEPARATOR TANK	1
6	TEMPERATURE SENSOR	1
5	MAIN MOTOR	1
4	AIREND	1
3	INTAKE VALVE (NC)	1
2	CHOKE INDICATOR	1
1	AIR FILTER	1
S.NO	DESCRIPTION	QTY

OVER	6	30	120	315	1000	2000	4000
UP TO & INCL.	6	30	120	315	1000	2000	4000
TOLERANCE	±0.1	±0.2	±0.3	±0.5	±0.8	±1.2	±2

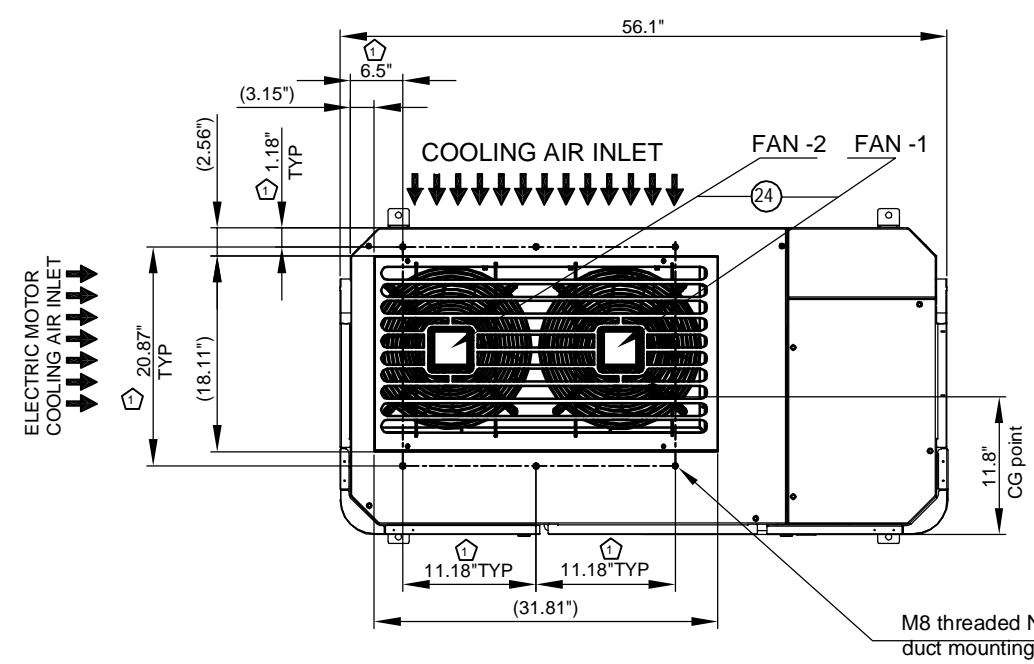

POWER (HP)	PRESSURE (psi)	MODEL	TPL NO.	WEIGHT (approx.) (lb)
20	100	c	S011801	1245
		cv	S012030	1271
	125	c	S011802	1245
		cv	S012031	1271
	150	c	S011803	1245
		cv	S012032	1271
25	175	c	S011804	1245
		cv	S012033	1271
		c	S011805	1499
30	100	c	S011809	1453
		cv	S012038	1598
	125	c	S011810	1453
		cv	S012039	1598
	150	c	S011811	1453
		cv	S012040	1598
175	c	S011812	1389	
	cv	S012041	1444	

POWER (HP)	PRESSURE (psi)	MODEL	TPL NO.	WEIGHT (approx.) (lb)
20	100	c	S011801	1245
		cv	S012030	1271
	125	c	S011802	1245
		cv	S012031	1271
	150	c	S011803	1245
		cv	S012032	1271
25	175	c	S011804	1245
		cv	S012033	1271
		c	S011805	1499
30	100	c	S011809	1453
		cv	S012038	1598
	125	c	S011810	1453
		cv	S012039	1598
	150	c	S011811	1453
		cv	S012040	1598
175	c	S011812	1389	
	cv	S012041	1444	

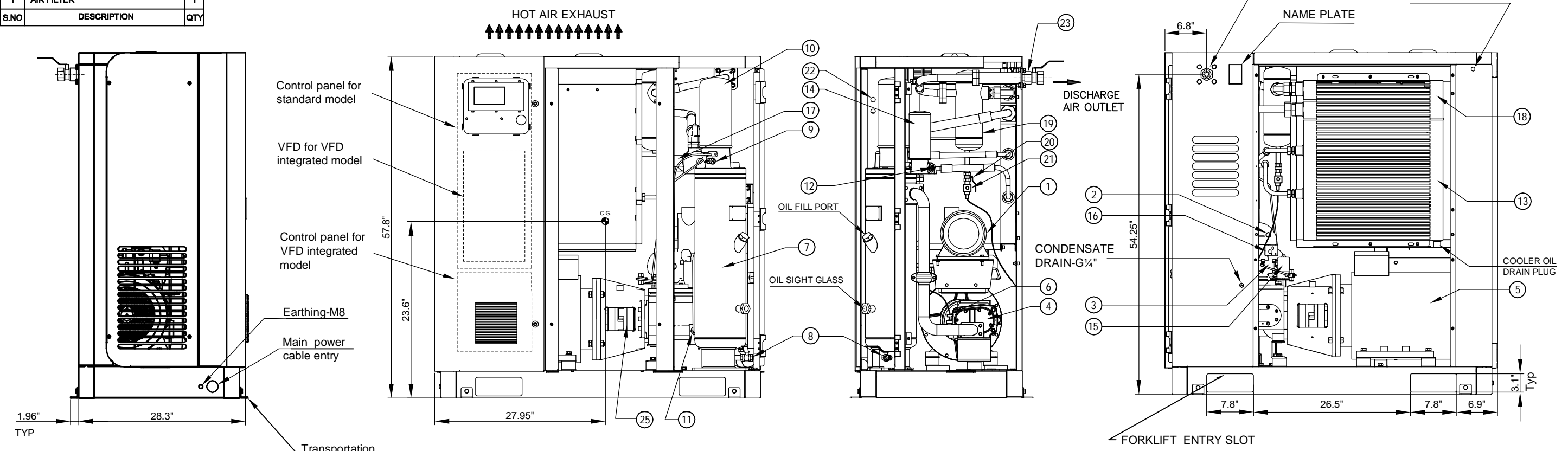

NOTE:-  
 ① INDICATES DUCTING DIMENSION  
 2. COOLING AIR FLOW FOR DUCTING 4120 cfm  
 3. MINIMUM DISTANCE REQUIRED AROUND THE COMPRESSOR IS 3.3 FEET AT ALL SIDES AND 6.6 FEET AT TOP (INSTALLATION REQUIREMENT)  
 # VFD AVAILABLE WITH CV VERSION ONLY

REFERENCE COPY

CONFIGURATIONS  
 (C) BASIC = STANDARD VERSION  
 (CV) OPTION #1 = STANDARD + VARIABLE FREQUENCY DRIVE VERSION

Sl.No.	DESCRIPTION	Qty.	DRAWING No.	Rev.	REMARKS
MODEL : F2- Global series - 230V/460V,60Hz - USA			<b>ELGI EQUIPMENTS LTD.,</b> COIMBATORE - INDIA.		
MATERIAL : -					
20, 25 & 30 HP GENERAL ASSEMBLY					
C AND CV					
DESIGNED	P.AK	18.07.11	RPF.DRG.No.      NEXT ASSY.		
CAD	P.AK	18.07.11			
CHECKED			SCALE	DRG.No. <b>01 53 0626 3</b> DRG.SHEET <b>1</b> OF <b>2</b> REVISION <b>R01</b>	
APPROVED			NTS		

9018	26.11.12	CV model TPL nos updated in sheet 1, Legends updated in sheet 2, Ducting dimensions added, MKS dimensioning system changed to FPS	MMS	SURYA	
REV. NO.	ECO.No.	DATE	DESCRIPTION	ALT. BY	CHKD. BY
6	5				

DO NOT SCALE THIS DRG. IF IN DOUBT, ASK ENGG. DEPT.