



**Refrigerated air dryer**

**EGRD**  
**600 - 2900**  
**Air – water cooled**

**EN - Operation, maintenance and troubleshooting  
manual**

---

Dear Customer,

thank you for choosing our product. In order to get the best performances out of this product, please read this manual carefully.

To avoid incorrect operation of the equipment and possible physical risk to the operator, please read and strictly follow the instructions contained in this manual.

Note, these instructions are in addition to the safety rules that apply in the country where the dryer is installed.

Before packing for shipment each **EGRD** series refrigerated air dryer undergoes a rigorous test to ensure the absence of any manufacturing faults and to demonstrate that the device can perform all the functions for which it has been designed.

Once the dryer has been properly installed according to the instructions in this manual, it will be ready for use without any further adjustment. The operation is fully automatic, and the maintenance is limited to few controls and some cleaning operations, as detailed in the following chapters.

**This manual must be maintained available in any moment for future references and it has to be intended as inherent part of the relevant dryer.**

Due to the continuous technical evolution, we reserve the right to introduce any necessary change without giving previous notice.

Should you experience any trouble, or for further information, please do not hesitate to contact us.

---

## Contents

<b>1</b>	<b>Identification plate</b>	<b>5</b>
<b>2</b>	<b>Warranty conditions</b>	<b>5</b>
<b>3</b>	<b>Safety rules</b>	<b>6</b>
3.1	Definition of the conventional signs used in this manual	6
3.2	Warnings	7
3.3	Proper use of the dryer	7
3.4	Instructions for the use of pressure equipment according to PED directive 97/23/EC	8
<b>4</b>	<b>Installation</b>	<b>8</b>
4.1	Transport	8
4.2	Storage	8
4.3	Installation site	9
4.4	Installation layout	10
4.5	Correction factors	11
4.6	Connection to the compressed air system	12
4.6.1	Inlet / outlet flanged air connections (only EGRD 600 – 1254)	12
4.7	Connection to the cooling water network (Water-Cooled)	13
4.8	Electrical connections	14
4.9	Condensate drain	15
<b>5</b>	<b>Start-up</b>	<b>15</b>
5.1	Preliminary operation	15
5.2	First start-up	16
5.3	Start-up and shut down	17
<b>6</b>	<b>Technical data</b>	<b>18</b>
6.1	Technical data EGRD 600 – 2900 3/460/60	18
<b>7</b>	<b>Technical description</b>	<b>19</b>
7.1	Control panel	19
7.2	Operation	19
7.3	Flow diagram (Air-Cooled)	20
7.4	Flow diagram (Water-Cooled)	20
7.5	Refrigerating compressor	21
7.6	Condenser (Air-Cooled)	21
7.7	Condenser (Water-Cooled)	21
7.8	Condenser water regulating valve (Water-Cooled)	21
7.9	Filter dryer	21
7.10	Capillary tube	22
7.11	Alu-Dry module	22
7.12	Hot gas by-pass valve	22
7.13	Refrigerant pressure switches LPS – HPS	23
7.14	Compressor crankcase heater	23
7.15	Electronic instrument DMC24	24
7.15.1	How to switch on the dryer	25
7.15.2	How to switch off the dryer	25
7.15.3	How to display the operating parameters – INFO Menu	25
7.15.4	How a service warning is displayed	26
7.15.5	How an alarm is displayed	27
7.15.6	How to show the alarm memory – LOG Menu	28
7.15.7	How to control dryer with remote control	28
7.15.8	Operation of the failure / alarm dry contact (potential free)	28
7.15.9	Connection to serial line	28
7.15.10	How to change operating parameters – SETUP Menu	29
7.16	Electronic drainer	30
<b>8</b>	<b>Maintenance, troubleshooting, spare parts and dismantling</b>	<b>31</b>
8.1	Checks and maintenance	31
8.2	Troubleshooting	32

---

8.3	Maintenance operation on the refrigeration circuit	37
8.4	Dismantling of the dryer	37
<b>9</b>	<b>Attachments</b>	<b>38</b>
	Exploded views – List of components	38
	Electric diagrams – List of components	38
9.1	Dryers dimensions	39
9.1.1	EGRD 600 – 1254	39
9.1.2	EGRD 1552 – 2900	40
9.2	Exploded views	41
9.2.1	EGRD 600 – 1254 Air Cooled	41
9.2.2	EGRD 600 – 1254 Water Cooled	42
9.2.3	EGRD 1552 – 2900 Air Cooled	43
9.2.4	EGRD 1552 – 2900 Water Cooled	44
9.3	Electric diagrams	45
9.3.1	EGRD 600 – 1254 Sheet 1 of 3	45
9.3.2	EGRD 600 – 1254 Sheet 2 of 3	46
9.3.3	EGRD 600 – 1254 Sheet 3 of 3	47
9.3.4	EGRD 1552 – 2900 Sheet 1 of 4	48
9.3.5	EGRD 1552 – 2900 Sheet 2 of 4	49
9.3.6	EGRD 1552 – 2900 Sheet 3 of 4	50
9.3.7	EGRD 1552 – 2900 Sheet 4 of 4	51
<b>10</b>	<b>Blank pages</b>	<b>52</b>

### **1 Identification plate**

The identification plate is located on the back of the dryer and shows all the primary data of the machine. This data should always be referred to when calling the manufacturer or distributor. The removal or alteration of the identification plate will void the warranty rights.

### **2 Warranty conditions**

For 12 months from the installation date, but no longer than 18 months from the delivery date, the warranty covers eventual faulty parts, which will be repaired or replaced free of charge, except the travel, hotel and restaurant expenses of our engineer.

The warranty doesn't cover any responsibility for direct or indirect damages to persons, animals or equipment caused by improper usage or maintenance, and it's limited to manufacturing faults only.

The right to warranty repairs is subordinated to the strict compliance with the installation, use and maintenance instructions contained in this manual.

The warranty will be immediately voided in case of even small changes or alterations to the dryer. To require repairs during the warranty period, the data reported on the identification plate must be notified.

### 3 Safety rules

#### 3.1 Definition of the conventional signs used in this manual



Carefully read instruction manual before attempting any service or maintenance procedures on the dryer.



Caution warning sign. Risk of danger or possibility of damage to equipment, if related text is not followed properly.



Electrical hazard. Warning message indicates practices or procedures that could result in personal injury or fatality if not followed correctly.



Danger hazard. Part or system under pressure.



Danger hazard. High temperature conditions exist during operation of system. Avoid contact until system or component has dissipated heat.



Danger hazard. Treated air is not suitable for breathing purposes; serious injury or fatality may result if precautions are not followed.



Danger hazard: In case of fire, use an approved fire extinguisher, water is not an acceptable means in cases of fire.



Danger hazard. Do not operate equipment with panels removed.



Maintenance or control operation to be performed by qualified personnel only [1].



Compressed air inlet connection point



Compressed air outlet connection point



Condensate drain connection point

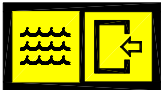

Cooling water inlet connection point (Water-Cooled)



Cooling water outlet connection point (Water-Cooled)



Operations which can be performed by the operator of the machine, if qualified [1].

**NOTE:** Text that specifies items of note to be taken into account does not involve safety precautions.



In designing this unit a lot of care has been devoted to environmental protection:

- CFC free refrigerants
- CFC free insulation parts
- Energy saving design
- Limited acoustic emission
- Dryer and relevant packaging composed of recyclable materials

This symbol requests that the user heed environmental considerations and abide with suggestions annotated with this symbol.

[1] Experienced and trained personnel familiar with national and local codes, capable to perform the needed activities, identify and avoid possible dangerous situations while handling, installing, using and servicing the machine. Ensuring compliance to all statutory regulations.

### 3.2 Warnings



Compressed air is a highly hazardous energy source.

Never work on the dryer with pressure in the system.

Never point the compressed air or the condensate drain outlet hoses towards anybody.



The user is responsible for the proper installation of the dryer. Failure to follow instructions given in the "Installation" chapter will void the warranty. Improper installation can create dangerous situations for personnel and/or damages to the machine could occur.



Only qualified personnel are authorized to service electrically powered devices. Before attempting maintenance, the following conditions must be satisfied:

- Ensure that main power is off, machine is locked out, tagged for service and power cannot be restored during service operations.
- Ensure that valves are shut and the air circuit is at atmospheric pressure. De-pressurize the dryer.



These refrigerating air dryers contain R407C HFC type refrigerant fluid. Refer to the specific paragraph - maintenance operation on the refrigerating circuit.



Warranty does not apply to any unit damaged by accident, modification, misuse, negligence or misapplication. Unauthorized alterations will immediately void the warranty.



In case of fire, use an approved fire extinguisher, water is not an acceptable means in cases of electrical fire.

### 3.3 Proper use of the dryer

This dryer has been designed, manufactured and tested for the purpose of separating the humidity normally contained in compressed air. Any other use has to be considered improper.

The Manufacturer will not be responsible for any problem arising from improper use; the user will bear responsibility for any resulting damage.

Moreover, the correct use requires the adherence to the installation instructions, specifically:

- Voltage and frequency of the main power.
- Pressure, temperature and flow-rate of the inlet air.
- Pressure, temperature and cooling water capacity (Water-Cooled).
- Ambient temperature.

This dryer is supplied tested and fully assembled. The only operation left to the user is the connection to the plant in compliance with the instructions given in the following chapters.



The purpose of the machine is the separation of water and eventual oil particles present in compressed air.



The dried air cannot be used for breathing purposes or for operations leading to direct contact with foodstuff.

This dryer is not suitable for the treatment of dirty air or of air containing solid particles.

### 3.4 Instructions for the use of pressure equipment according to PED directive 97/23/EC

To ensure the safe operation of pressure equipments, the user must conform strictly to the above directive and the following:

1. The equipment must only be operated within the temperature and pressure limits stated on the manufacturer's data nameplate.
2. Welding on heat-exchanger is not recommended.
3. The equipment must not be stored in badly ventilated spaces, near a heat source or inflammable substances.
4. Vibration must be eliminated from the equipment to prevent fatigue failure.
5. Automatic condensate drains should be checked for operation every day to prevent a build up of condensate in the pressure equipment.
6. The maximum working pressure stated on the manufacturer's data nameplate must not be exceeded. Prior to use, the user must fit safety / pressure relief devices.
7. All documentation supplied with the equipment (manual, declaration of conformity etc.) must be kept for future reference.
8. Do not apply weights or external loads on the vessel or its connecting piping.



**TAMPERING, MODIFICATION AND IMPROPER USE OF THE PRESSURE EQUIPMENT ARE FORBIDDEN. Users of the equipment must comply with all local and national pressure equipment legislation in the country of installation.**

## 4 Installation

### 4.1 Transport

Check for visible loss or damage, if no visible damage is found place the unit near to the installation point and unpack the contents.

- To move the packaged unit we recommend using a suitable trolley or forklift truck. Hand carrying is not recommended
- Always keep the dryer in the upright vertical position. Damage to components could result if unit is laid on its side or if placed upside down.
- Handle with care. Heavy blows could cause irreparable damage.

### 4.2 Storage

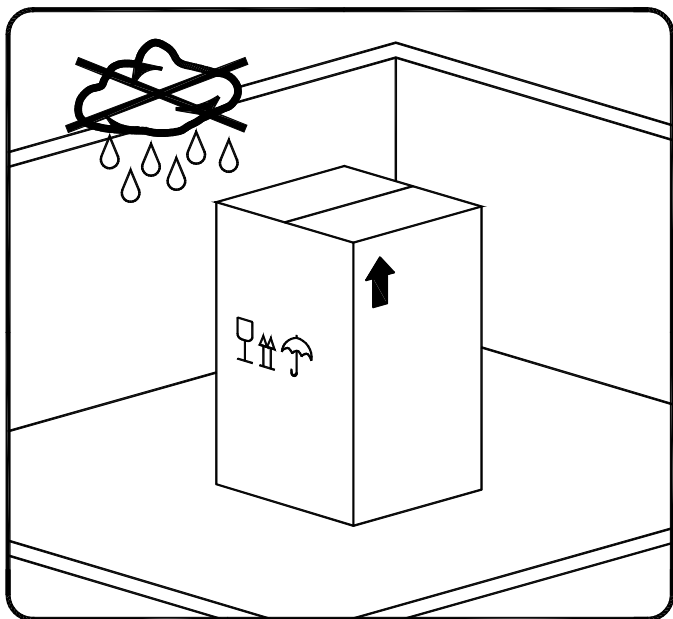

Even when packaged, keep the machine protected from severity of the weather.

Keep the dryer in vertical position, also when stored. Turning it upside down some parts could be irreparably damaged.

If not in use, the dryer can be stored in its packaging in a dust free and protected site at a temperature of 32°F (0°C) ... 122°F (50°C), and a specific humidity not exceeding 90%. Should the stocking time exceed 12 months, please contact the manufacturer.



The packaging materials are recyclable. Dispose of material in compliance with the rules and regulations in force in the destination country.

### 4.3 Installation site



Failure to install dryer in the proper ambient conditions will affect the dryer's ability to condense refrigerant gas. This can cause higher loads on the compressor, loss of dryer efficiency and performance, overheated condenser fan motors, electrical component failure and dryer failure due to the following: compressor loss, fan motor failure and electrical component failure. Failures of this type will affect warranty considerations.

Do not install dryer in an environment of corrosive chemicals, explosive gasses, poisonous gasses; steam heat, areas of high ambient conditions or extreme dust and dirt.



In case of fire, use an approved fire extinguisher, water is not an acceptable means in cases of fire.

#### **Minimum installation requirements:**

- Select a clean dry area, free from dust, and protected from atmospheric disturbances.
- The supporting area must be smooth, horizontal and able to hold the weight of the dryer.
- Minimum ambient temperature +34°F (+1°C).
- Maximum ambient temperature +122°F (+50°C).
- Ensure a proper cooling air replacement.
- Allow a sufficient clearance on each side of the dryer for proper ventilation and to facilitate maintenance operations.

The dryer does not require attachment to the floor surface.



Do not block, even partially, ventilation grid.  
Avoid any possible re-circulation of the exhaust cooling air.  
Protect the dryer from air drafts or forced cooling air conditions.

## 4.4 Installation layout

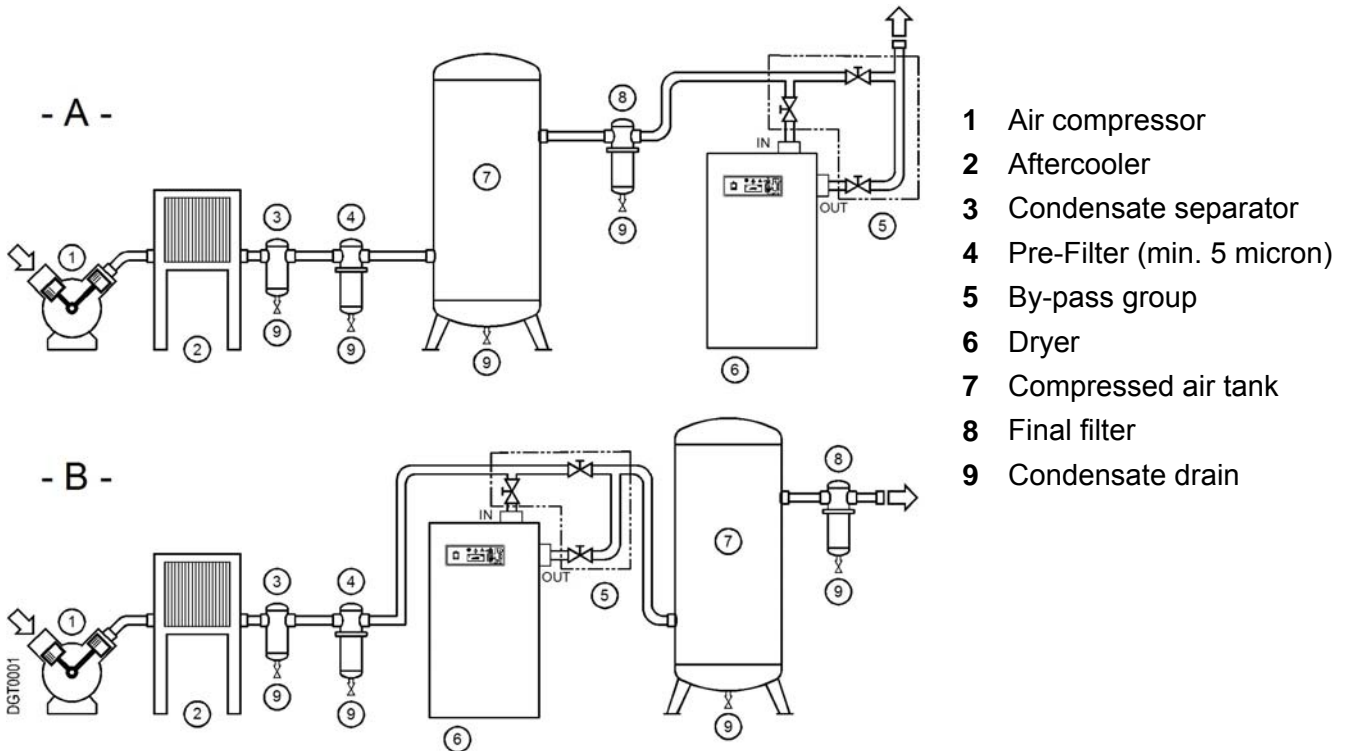

**In case of heavily polluted inlet air (ISO 8573.1 class 3.-.3 or worse quality), we recommend the additional installation of a pre-filter (5 micron minimum) to prevent a clogging of the heat exchanger.**

**Type A** installation is suggested when the compressor operates at reduced intermittence and the total consumption equals the compressor flow rate.

**Type B** installation is suggested when the air consumption can consistently change with peak values highly exceeding the flow rate of the compressors. The capacity of the tank must be sized in order to compensate eventual instantaneous demanding conditions (peak air consumption).

## Installation

### 4.5 Correction factors

Correction factor for operating pressure changes:

Inlet air pressure	psig	60	80	100	120	140	160	180	203
	barg	4	5.5	7	8	10	11	12	14
Factor (F1)		0.79	0.91	1.00	1.07	1.13	1.18	1.23	1.27

Correction factor for ambient temperature changes (Air-Cooled):

Ambient temperature	°F	≤ 80	90	95	100	105	110	115	122
	°C	≤ 27	32	35	38	40	43	45	50
Factor (F2)		1.11	1.09	1.06	1.00	0.94	0.87	0.78	0.69

Correction factor for inlet air temperature changes:

Air temperature	°F	≤ 90	100	110	122	130	140	150	158
	°C	≤ 32	38	43	50	55	60	65	70
Factor (F3)		1.16	1.00	0.82	0.68	0.61	0.52	0.45	0.40

Correction factor for DewPoint changes:

DewPoint	°F	38	41	45	50
	°C	3	5	7	10
Factor (F4)		1.00	1.08	1.20	1.36

**How to find the air flow capacity:**

**Air flow capacity = Nominal duty x Factor (F1) x Factor (F2) x Factor (F3) x Factor (F4)**

**Example:**

An **EGRD 1100** has a nominal duty of 1000 scfm (1698 m<sup>3</sup>/h). What is the maximum allowable flow through the dryer under the following operating conditions:

Inlet air pressure = 120 psig (8 barg)	Factor (F1) = 1.07
Ambient temperature = 115°F (45°C)	Factor (F2) = 0.78
Inlet air temperature = 122°F (50°C)	Factor (F3) = 0.68
Pressure DewPoint = 50°F (10°C)	Factor (F4) = 1.36

Each item of data has a corresponding numerical factor which multiplied by the design air flow is as follows:

**Air flow capacity = 1000 x 1.07 x 0.78 x 0.68 x 1.36 = 772 scfm (1312 m<sup>3</sup>/h)**

**772 scfm (1312 m<sup>3</sup>/h)** This is the maximum flow rate that the dryer can accept under these operating conditions.

**How to select a suitable dryer for a given duty:**

**Minimum std. air flow rate =  $\frac{\text{Design air flow}}{\text{Factor (F1) x Factor (F2) x Factor (F3) x Factor (F4)}}$**

**Example:**

With the following operating parameters:

Design air flow = 750 scfm (1274 m <sup>3</sup> /h)	Factor (F1) = 1.07
Inlet air pressure = 120 psig (8 barg)	Factor (F2) = 0.78
Ambient temperature = 115°F (45°C)	Factor (F3) = 0.68
Inlet air temperature = 122°F (50°C)	Factor (F4) = 1.36
Pressure DewPoint = 50°F (10°C)	

In order to select the correct dryer model the required flow rate is to be divided by the correction factors relating to above mentioned parameters:

**Minimum std. air flow rate =  $\frac{750}{1.07 \times 0.78 \times 0.68 \times 1.36} = 972 \text{ scfm (1652 m}^3\text{/h)}$**

Therefore the model suitable for the conditions above is **EGRD 1100 (1000 scfm [1698 m<sup>3</sup>/h] - nominal duty)**.

4.6 Connection to the compressed air system



Operations to be performed by qualified personnel only.

Never work on system under pressure.



The user is responsible to ensure that the dryer will never be operated with pressure exceeding the maximum pressure rating on the unit data tag.

Over-pressurizing the dryer could be dangerous for both the operator and the unit.

The air temperature and the flow entering the dryer must comply within the limits stated on the data nameplate. The system connecting piping must be kept free from dust, rust, chips and other impurities, and must be consistent with the flow-rate of the dryer. In case of treatment of air at particularly high temperature, the installation of a final refrigerator could result necessary. In order to perform maintenance operations, it is recommended to install a dryer by-pass system.



**In case of heavily polluted inlet air (ISO 8573.1 class 3.-.3 or worse quality), we recommend the additional installation of a pre-filter (5 micron minimum) to prevent a clogging of the heat exchanger.**

In realising the dryer, particular measures have been taken in order to limit the vibration which could occur during the operation. Therefore we recommend to use connecting pipes able to insulate the dryer from possible vibrations originating from the line (flexible hoses, vibration damping fittings, etc.).

4.6.1 Inlet / outlet flanged air connections (only EGRD 600 – 1254)

Inlet / outlet flanged air connections and Victaulic® joints are located inside the box under the dryer (see Fig.1).



Assembly flange (B) and Victaulic® joint (A) as shown in Fig.2

**Pay particular attention in not damaging the gasket of Victaulic® joint (A).**

Fully tighten the two bolts of Victaulic® joint (see Fig.3)

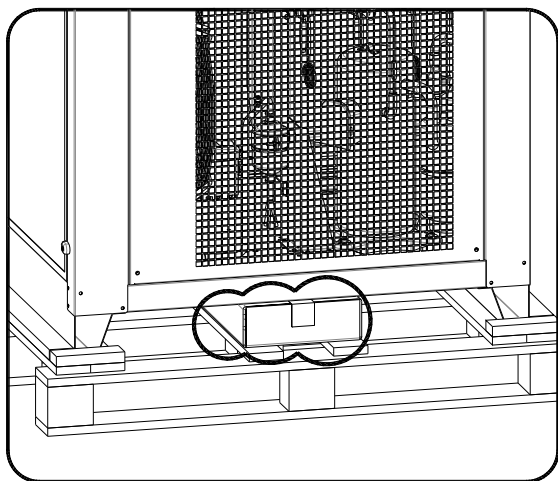

Fig.1

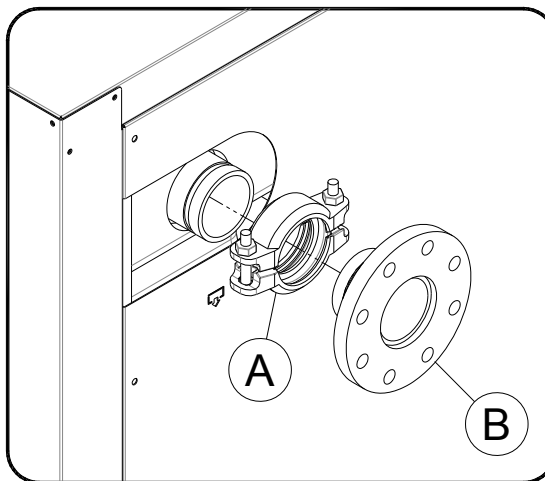

Fig.2

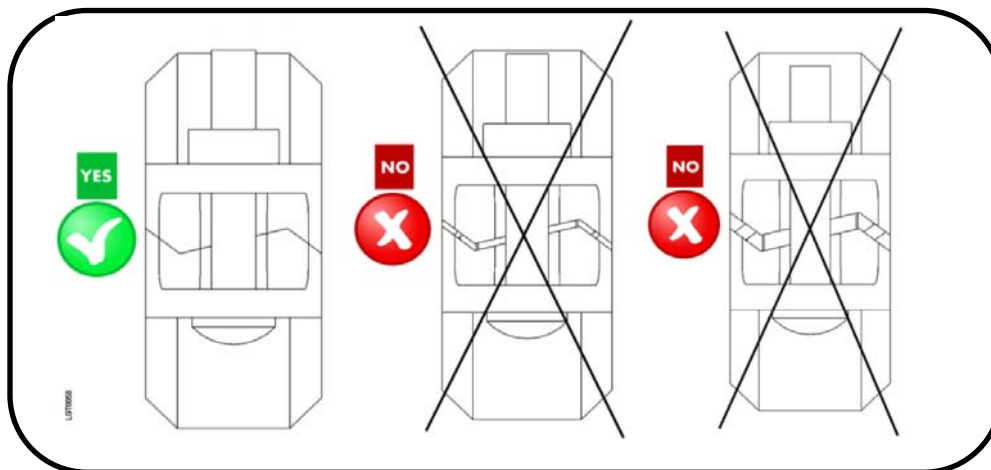

Fig.3

## 4.7 Connection to the cooling water network (Water-Cooled)



Operations to be performed by qualified personnel only.

Never work on system under pressure.

The user is responsible to ensure that the dryer will never be operated with pressure exceeding the maximum pressure rating on the unit data tag.

Over-pressurizing the dryer could be dangerous for both the operator and the unit.

The temperature and the amount of cooling water must comply with the limits indicated on the technical characteristics chart. The cross section of the connection pipes, preferably flexible, must be free from rust, chips and other impurities. We recommend to use connecting pipes able to insulate the dryer from possible vibrations originating from the line (flexible hoses, vibration damping fittings, etc.).



We recommend the installation of a 500 micron filter to prevent a clogging of the heat exchanger.

### Minimum cooling water requirements:

Temperature	59...86°F (15...30°C) (1)	HCO <sub>3</sub> / SO <sub>4</sub>	>1.0 mg/l or ppm
Pressure	44...145 psig (3...10 barg) (2)	NH <sub>3</sub>	<2 mg/l or ppm
Head pressure	> 44 psig (3 bar) (2) (3)	Cl <sup>-</sup>	50 mg/l or ppm
Total hardness	6.0...15 dH°	Cl <sub>2</sub>	0.5 mg/l or ppm
PH	7.5...9.0	H <sub>2</sub> S	<0.05 mg/l or ppm
Conductivity	10...500 µS/cm	CO <sub>2</sub>	<5 mg/l or ppm
Residual solid particles	<30 mg/l or ppm	NO <sub>3</sub>	<100 mg/l or ppm
Saturation Index SI	-0.2 < 0 < 0.2	Fe	<0.2 mg/l or ppm
HCO <sub>3</sub>	70...300 mg/l or ppm	Al	<0.2 mg/l or ppm
SO <sub>4</sub> <sup>2-</sup>	<70 mg/l or ppm	Mn	<0.1 mg/l or ppm

Note : (1) – Other temperature on request - Check the data shown on the identification plate.

(2) – Other pressure on request - Check the data shown on the identification plate.

(3) – Pressure difference at dryer water connection points at maximum water flow - Other head pressure on request



### CAUTION :

**PIPING THE DRYER, INLET/OUTLET CONNECTIONS MUST BE SUPPORTED AS SHOWN IN THE DIAGRAM.**

**FAILING WILL RESULT IN DAMAGE.**

## 4.8 Electrical connections



Qualified personnel should carry out connecting unit to the main power.  
Be sure to check the local codes in your area.

Before connecting the unit to the electrical supply, verify the data nameplate for the proper electrical information. Voltage tolerance is +/- 10%. The installer is responsible for supplying and installing the power cable. Be sure to provide the proper fuses or breakers based on the data information located on the nameplate.

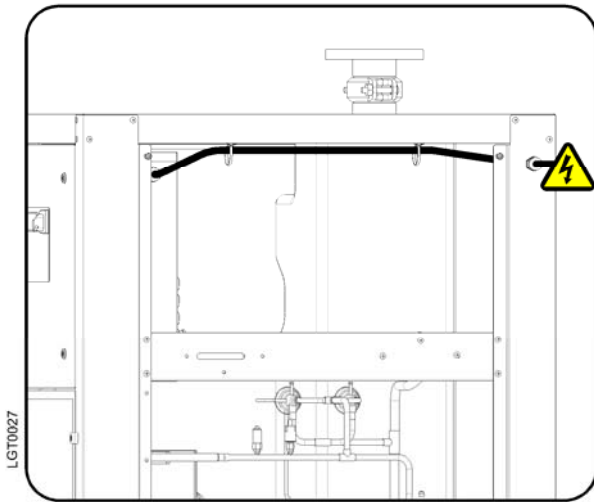

EGRD 600 – 1254

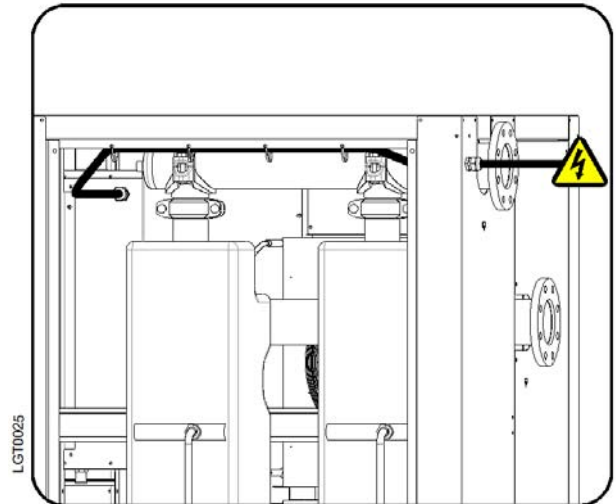

EGRD 1552 – 2900

A residual-current device (RCD) with  $I_{\Delta n} = 0.03A$  is suggested. The cross section of the power supply cables must comply with the consumption of the dryer, while keeping into account also the ambient temperature, the conditions of the mains installation, the length of the cables, and the requirements enforced by the local Power Provider.

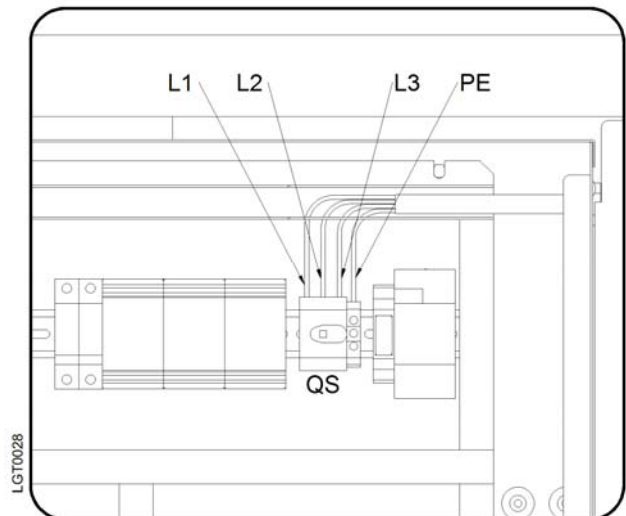

### CAUTION:

**ATTENTION SHOULD BE PAID ON THE ROTATING DIRECTION OF THE COMPRESSOR !**

The rotating direction of the compressor in this machine is checked out by a Reverse Phase Protector (RPP).

When this protection trips, the DMC24 is engaged (the alarm led flashes and the DMC24 display shows **OFF** and **Con**). If the compressor does not run, the rotating direction must be changed by swapping two phases. These changes have to be done only by a qualified electrician.

**DO NOT BY PASS RPP PROTECTION: BY OPERATING THE MACHINE IN WRONG ROTATING DIRECTION, THE COMPRESSOR WILL FAIL IMMEDIATELY AND THE WARRANTY WILL BE VOIDED.**



Important: ensure that the dryer is earthed.

Do not use any socket adapters at the mains plug.

If the mains plug needs to be replaced, this must only be done by a qualified electrician.

### 4.9 Condensate drain



The condensate is discharge at the system pressure.  
Drain line should be secured.



Never point the condensate drain line towards anybody.

The dryer comes already fitted with an electronic condensate drainer.  
Connect and properly fasten the condensate drain to a collecting plant or container.  
The drain cannot be connected to pressurized systems.



Don't dispose the condensate in the environment.  
The condensate collected in the dryer contains oil particles released in the air by the compressor.  
Dispose the condensate in compliance with the local rules.  
We recommend to install a water-oil separator where to convey all the condensate drain coming from compressors, dryers, tanks, filters, etc.

## 5 Start-up

### 5.1 Preliminary operation



Verify that the operating parameters match with the nominal values stated on the data nameplate of the dryer (voltage, frequency, air pressure, air temperature, ambient temperature, etc.).

This dryer has been thoroughly tested, packaged and inspected prior to shipment. Nevertheless, the unit could be damaged during transportation, check the integrity of the dryer during first start-up and monitor operation during the first hours of operation.



Qualified personnel must perform the first start-up.  
When installing and operating this equipment, comply with all National Electrical Code and any applicable federal, state and local codes.



Who is operating the unit is responsible for the proper and safe operation of the dryer.  
Never operate equipment with panels removed.



## 5.2 First start-up



This procedure should be followed on first start-up, after periods of extended shutdown or following maintenance procedures. Qualified personnel must perform the start-up.



### Sequence of operations (refer to paragraph 7.1 Control Panel).

- Ensure that all the steps of the “Installation” chapter have been observed.
- Ensure that the connection to the compressed air system is correct and that the piping is suitably fixed and supported.
- Ensure that the condensate drain pipe is properly fastened and connected to a collection system or container.
- Ensure that the by-pass system (if installed) is closed and the dryer is isolated.
- Ensure that the manual valve of the condensate drain circuit is open.
- Remove any packaging and other material which could obstruct the area around the dryer.
- Activate the mains switch.
- Turn on the main switch - pos. 1 on the control panel.
- The electronic instrument DMC24 shows **OFF**.
- **If the alarm led flashes  and display DMC24 shows **OFF** and **Err** the electrical power phases are not correctly connected. Change two of the three phases on the main power supply (see paragraph 4.8)**
- Wait at least two hours before starting the dryer (compressor crankcase heater must heat the oil of the compressor).
- Ensure the cooling water flow and temperature is adequate (Water-Cooled).
- Press key  for at least 2 seconds to start the dryer: if the compressor has been shut down for enough time, it will start up immediately; otherwise the display will show the countdown of the seconds before the compressor starts up again, and the led  flashes (max delay 5 minutes).
- Ensure the consumption matches with the values of the data plate.
- Check the rotation direction of the fan – wait for its first interventions (Air-Cooled).
- Allow the dryer temperature to stabilise at the pre-set value.
- Slowly open the air inlet valve.
- Slowly open the air outlet valve.
- Slowly close the central by-pass valve of the system (if installed).
- Check the piping for air leakage.
- Ensure the drain is regularly cycling - wait for its first interventions.



### CAUTION:

### ATTENTION SHOULD BE PAID ON THE ROTATING DIRECTION OF THE COMPRESSOR !

The rotating direction of the compressor in this machine is checked out by a Reverse Phase Protector (RPP).

When this protection trips, the DMC24 is engaged (the alarm led flashes  and the DMC24 display shows **OFF** and **Err**). If the compressor does not run, the rotating direction must be changed by swapping two phases. These changes have to be done only by a qualified electrician.

**DO NOT BY PASS RPP PROTECTION: BY OPERATING THE MACHINE IN WRONG ROTATING DIRECTION, THE COMPRESSOR WILL FAIL IMMEDIATELY AND THE WARRANTY WILL BE VOIDED.**



### 5.3 Start-up and shut down



For short periods of inactivity, (max 2-3 days) we recommend that power is maintained to the dryer and the control panel. Otherwise, before re-starting the dryer, it is necessary to wait at least 2 hours for the compressor crankcase heater to heat the oil of the compressor.



#### Start-up (refer to paragraph 7.1 Control Panel)

- Check the condenser for cleanliness (Air-Cooled).
- Ensure the cooling water flow and temperature is adequate (Water-Cooled).
- The electronic instrument DMC24 shows **oFF**.
- Press key  for at least 2 seconds to start the dryer: if the compressor has been shut down for enough time, it will start up immediately; otherwise the display will show the countdown of the seconds before the compressor starts up again, and the led  flashes (max delay 5 minutes).
- Wait few minutes; verify that the DewPoint temperature displayed on electronic instrument is correct and that the condensate is regularly drained.
- Switch on the air compressor.



#### Shut down (refer to paragraph 7.1 Control Panel)

- Check that the DewPoint temperature indicated on the electronic instrument is within range.
- Shut down the air compressor.
- After few minutes, shut down the dryer keeping the  button on DMC24 pressed for at least 2 seconds. The display shows **oFF**.



#### Dryer remote control ON-OFF

- See instructions on paragraph 7.15.7



**Use dry contacts only (potential free) suitable for low voltage. Assure an adequate isolation of potentially dangerous powered parts.**



**CAUTION :**

**AUTO-RESTART / REMOTE ON-OFF.**

**THE DRYER MAY POWER UP WITHOUT BEING ACTED UPON.**

**THE USER WILL BE RESPONSIBLE FOR THE INSTALLATION OF PROPER PROTECTIONS FOR POSSIBLE SUDDEN POWER RESTORATION TO THE DRYER.**

**NOTE :** A DewPoint within 32°F (0°C) and +50°F (+10°C) displayed on electronic instrument is correct according to the possible working conditions (flow-rate, temperature of the incoming air, ambient temperature, etc.).

During the operation, the refrigerant compressor will run continuously. The dryer must remain on during the full usage period of the compressed air, even if the air compressor works intermittently.



**The number of starts must be no more than 6 per hour.**

The dryer must stop running for at least 5 minutes before being started up again.

Frequent starts may cause irreparable damage.

The user is responsible for compliance with these rules.

The DMC24 is fitted with internal protections to prevent the dryer from starting up too frequently.

6 Technical data

6.1 Technical data EGRD 600 – 2900 3/460/60

MODEL	EGRD	600	750	1100	1254	1552	1750	2000	2900
Air flow rate at nominal condition (1)	[scfm] [m <sup>3</sup> /h] [l/min]	600 1019 16980	800 1358 22640	1000 1698 28300	1250 2123 35375	1500 2547 42450	1750 2972 49525	2000 3396 56600	2500 4245 70750
Pressure DewPoint at nominal condition (1)	[°F (°C)]	38 (3)							
Nominal ambient temperature	[°F (°C)]	100 (38)							
Min...Max ambient temperature	[°F (°C)]	34...122 (1...50)							
Nominal inlet air temperature	[°F (°C)]	100 (38) max.158 (70)							
Nominal inlet air pressure	[psig (barg)]	100 (7)							
Max. inlet air pressure	[psig (barg)]	203 (14)							
Air pressure drop - Δp	[psi (bar)]	2.2 (0.15)	2.9 (0.20)	2.8 (0.19)	3.6 (0.25)	2.8 (0.19)	1.9 (0.13)	2.6 (0.18)	3.6 (0.25)
Inlet - Outlet connections	[FL ANSII]	3" # 150			4" # 150				

Air-Cooled									
R407C									
Refrigerant type		R407C							
Refrigerant quantity (2)	[oz (kg)]	102 (2.90)	113 (3.20)	152 (4.30)	173 (4.90)	229 (6.50)	236 (6.70)	247 (7.00)	360 (10.20)
Cooling air fan flow	[cfm (m <sup>3</sup> /h)]	3500 (5900)	4700 (7900)	4800 (8200)	7100 (12000)	9400 (16000)	9400 (16000)	9700 (16500)	9700 (16500)
Heat Rejection	[btu/hr (kW)]	28100 (8.2)	35800 (10.5)	52200 (15.3)	66100 (19.4)	88000 (25.8)	90100 (26.4)	97100 (28.5)	131400 (38.5)
Standard Power Supply (2)	[Phr/V/Hz]	3/460/60							
Nominal electric consumption	[kW]	2.65	3.25	4.60	5.60	6.40	7.50	8.60	9.80
Full Load Amperage FLA	[A]	4.1	5.0	6.4	7.5	9.0	10.0	11.8	14.3
Max. noise level at 1 m	[dB(A)]	6.1	7.1	10.5	11.5	14.7	16.5	18.4	23.0
Weight	[lb (kg)]	529 (240)	534 (242)	608 (276)	686 (311)	1021 (463)	1186 (538)	1190 (540)	1349 (612)

Water-Cooled									
R407C									
Refrigerant type		R407C							
Refrigerant quantity (2)	[oz (kg)]	92 (2.60)	102 (2.90)	137 (3.90)	155 (4.40)	208 (5.90)	212 (6.00)	222 (6.30)	324 (9.20)
Max. cooling water inlet temp (3)	[°F (°C)]	86 (30)							
Min...Max. cooling water inlet pressure	[psig (barg)]	45...145 (3...10)							
Cooling water flow at 15°C	[US gpm (m <sup>3</sup> /h)]	1.01 (0.23)	1.10 (0.25)	1.72 (0.39)	1.94 (0.44)	2.51 (0.57)	2.55 (0.58)	2.99 (0.68)	3.70 (0.84)
Cooling water flow at 30°C	[US gpm (m <sup>3</sup> /h)]	3.57 (0.81)	3.70 (0.84)	6.43 (1.46)	6.47 (1.47)	8.01 (1.82)	8.41 (1.91)	9.82 (2.23)	12.77 (2.90)
Heat Rejection	[btu/hr (kW)]	28100 (8.2)	35800 (10.5)	52200 (15.3)	66100 (19.4)	88000 (25.8)	90100 (26.4)	97100 (28.5)	131400 (38.5)
Control of cooling water flow		Automatic by valve							
Cooling water connection	[NPT-F]	3/4"			1"				
Standard Power Supply (2)	[Phr/V/Hz]	3/460/60							
Nominal electric consumption	[kW]	2.27	2.92	3.75	4.90	5.00	5.90	7.20	8.40
Full Load Amperage FLA	[A]	3.4	4.3	5.1	6.4	7.5	7.6	9.2	11.7
Max. noise level at 1 m	[dB(A)]	5.7	6.0	8.5	9.5	12.5	12.5	12.9	19.0
Weight	[lb (kg)]	496 (225)	500 (227)	567 (257)	635 (288)	950 (431)	1098 (498)	1102 (500)	1239 (562)

(1) The nominal condition refers to an ambient temperature of 100°F (38°C) with inlet air at 100 psig (7 barg) and 100°F (38°C).  
 (2) Check the data shown on the identification plate.  
 (3) Other temperature on request.

## 7 Technical description

### 7.1 Control panel

The control panel illustrated below is the only dryer-operator interface.

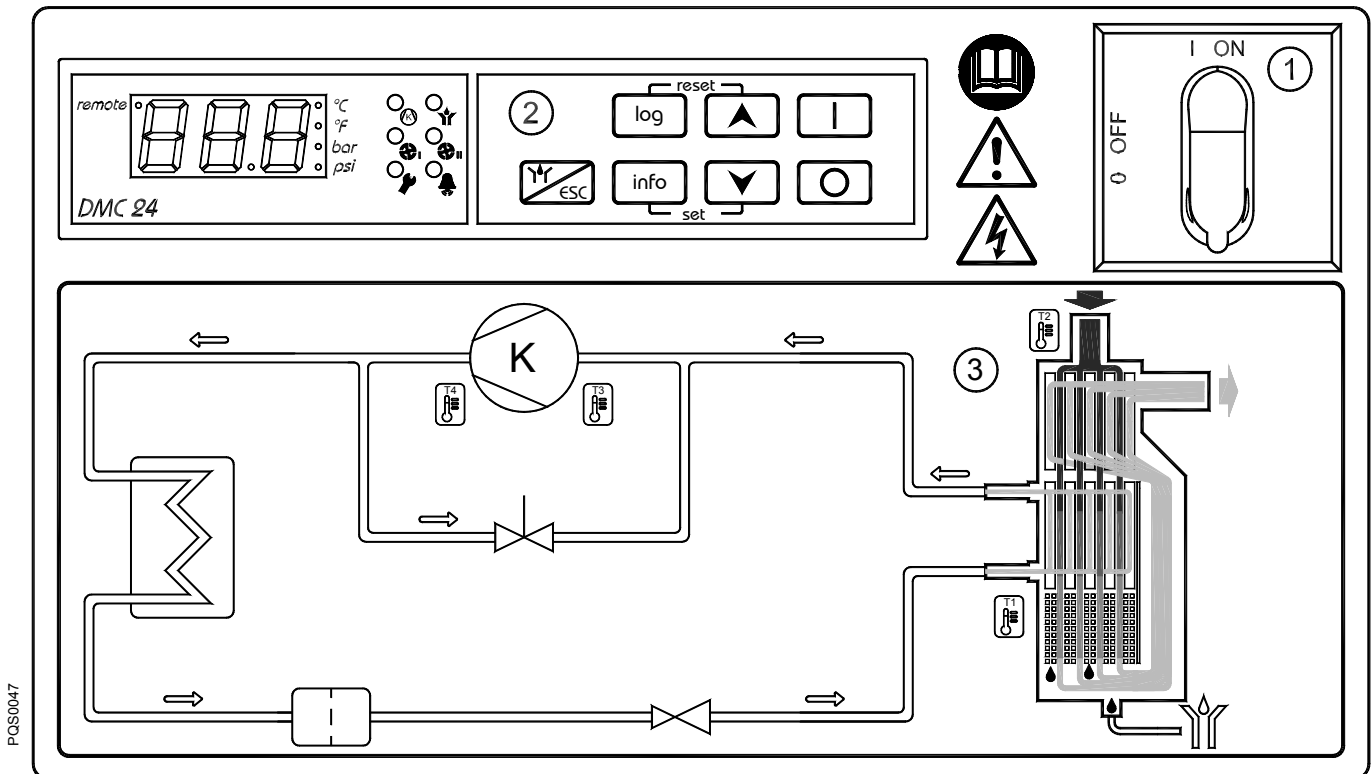

- 1 Main switch
- 2 Electronic instrument DMC24
- 3 Air and refrigerant flow diagram

### 7.2 Operation

**Operating principle** - The dryer models described in this manual operate all on the same principle. The hot moisture laden air enters an air to air heat exchanger. The air then goes through the evaporator, also known as the air to refrigerant heat exchanger. The temperature of the air is reduced to approximately 2°C, causing water vapor to condense to liquid. The liquid is continuously coalesced and collected in the separator for removal by the condensate drain. The cool moisture free air then passes back through the air to air heat exchanger to be reheated to within 8 degrees of the incoming air temperature as it exits the dryer.

**Refrigerant circuit** - Refrigerant gas is cycled through the compressor and exits at high pressure to a condenser where heat is removed causing the refrigerant to condense to a high-pressure liquid state. The liquid is forced through a capillary tube where the resulting pressure drop allows the refrigerant to boil off at a predetermined temperature. Low-pressure liquid refrigerant enters the heat exchanger where heat from the incoming air is transferred causing the refrigerant to boil; the resulting phase change produces a low pressure, low temperature gas. The low-pressure gas is returned to the compressor, where it is re-compressed and begins the cycle again. During those periods when the compressed air load is reduced the excess refrigerant is by-passed automatically back to the compressor via the hot gas by-pass valve circuit.

7.3 Flow diagram (Air-Cooled)

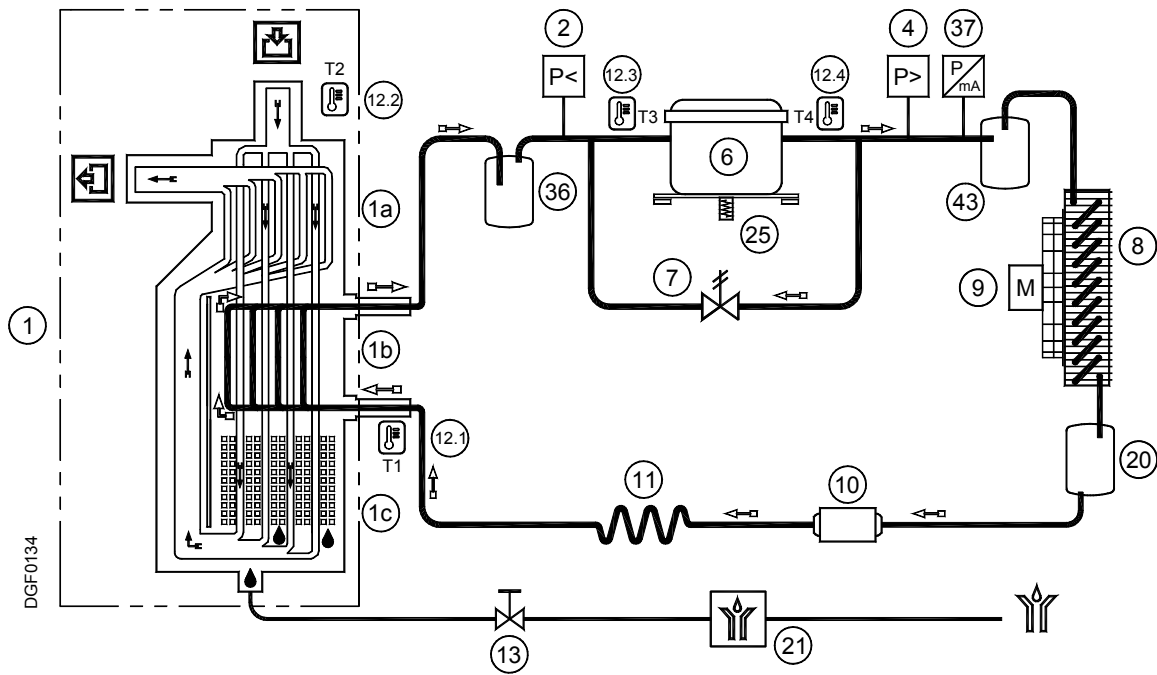

7.4 Flow diagram (Water-Cooled)

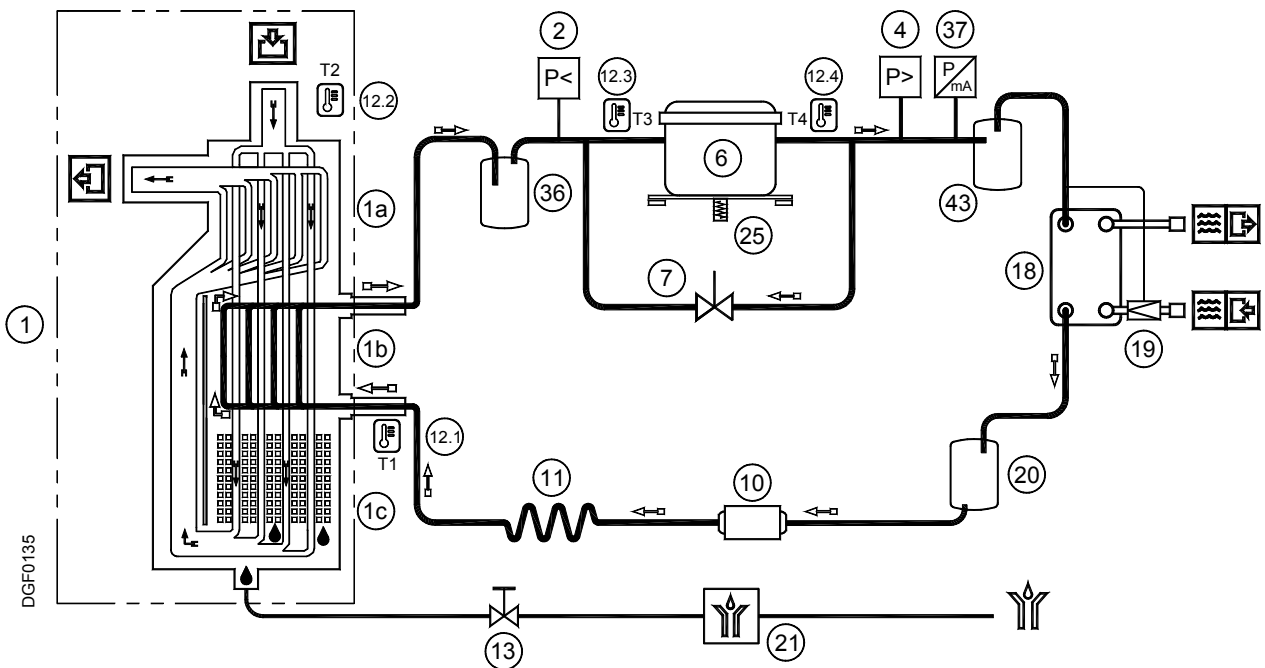

- |      |                                   |      |   |
|------|-----------------------------------|------|---|
| 1    | Alu-Dry module                    | 12.2 | T2 Temperature probe – Air IN                   |
| 1a   | Air-to-air heat exchanger         | 12.3 | T3 Temperature probe – Compressor suction       |
| 1b   | Air-to-refrigerant heat exchanger | 12.4 | T4 Temperature probe – Compressor discharge     |
| 1c   | Condensate separator              | 13   | Condensate drain service valve                  |
| 2    | Refrigerant pressure switch LPS   | 18   | Condenser (Water-Cooled)                        |
| 4    | Refrigerant pressure switch HPS   | 19   | Condenser water regulating valve (Water-Cooled) |
| 6    | Compressor                        | 20   | Refrigerant accumulator (Water Cooled)          |
| 7    | Hot gas by-pass valve             | 21   | Electronic drainer                              |
| 8    | Condenser (Air-Cooled)            | 25   | Compressor crankcase heater                     |
| 9    | Condenser fan (Air-Cooled)        | 36   | Liquid separator                                |
| 10   | Filter dryer                      | 37   | Refrigerant pressure transducer BHP             |
| 11   | Capillary tube                    | 43   | Oil separator (EGRD 1750-2900)                  |
| 12.1 | T1 Temperature probe – DewPoint   |      |   |
| ➔    | Compressed air flow direction     | ➔    | Refrigerant gas flow direction                  |

### 7.5 Refrigerating compressor

The refrigerating compressor is the pump in the system, gas coming from the evaporator (low pressure side) is compressed up to the condensation pressure (high pressure side). The compressors utilized are manufactured by leading manufacturers and are designed for applications where high compression ratios and wide temperature changes are present.

The hermetically sealed construction is perfectly gas tight, ensuring high-energy efficiency and long, useful life. Dumping springs support the pumping unit in order to reduce the acoustic emission and the vibration diffusion. The aspirated refrigerant gas, flowing through the coils before reaching the compression cylinders cools the electric motor. The thermal protection protects the compressor from over heating and over currents. The protection is automatically restored as soon as the nominal temperature conditions are reached.

### 7.6 Condenser (Air-Cooled)

The condenser is the component in which the gas coming from the compressor is cooled down and condensed becoming a liquid. Mechanically, a serpentine copper tubing circuit (with the gas flowing inside) is encapsulated in an aluminum fin package.

The cooling operation occurs via a high efficiency fan, creating airflow within the dryer, moving air through the fin package. It's mandatory that the ambient air temperature does not exceed the nominal values. It is also important to keep the condenser unit free from dust and other impurities.

### 7.7 Condenser (Water-Cooled)

The condenser is the component in which the gas coming from the compressor is cooled down and condensed becoming a liquid. Basically it is a water/refrigerating gas exchanger where the cooling water lowers the temperature of the refrigerating gas.

The temperature of the inlet water must not exceed the nominal values. It must also guarantee an adequate flow and that the water entering the exchanger is free from dust and other impurities.

### 7.8 Condenser water regulating valve (Water-Cooled)

The condenser water regulating valve is used to keep the condensing pressure/temperature constant when the Water-Cooled is being used. Thanks to the capillary tube, the valve detects the pressure in the condenser and consequently adjusts the water flow. When the dryer stops the valve automatically closes the cooling water flow.



The condenser water regulating valve is an operating control device.

The closure of the water circuit from the pressure condenser water regulating valve cannot be used as a safety closure during service operations on the system.



#### ADJUSTMENT

The condenser water regulating valve is adjusted during the testing phase to a pre-set value that covers 90% of the applications. However, sometimes the extreme operating conditions of the dryer may require a more accurate calibration.

During start-up, a qualified technician should check the condensing pressure/temperature and if necessary adjust the valve by using the screws on the valve itself.

To increase the condensing temperature, turn the adjusting screws counter-clockwise; to lower it turn the screws clock-wise.

Water valve setting : R407C pressure 232 psig ( $\pm 7.3$  psi) [16 barg ( $\pm 0.5$  bar)]

### 7.9 Filter dryer

Traces of humidity and slag can accumulate inside the refrigerant circuit. Long periods of use can also produce sludge. This can limit the lubrication efficiency of the compressor and clog the expansion valve or capillary tube. The function of the filter drier, located before the capillary tubing, is to eliminate any impurities from circulating through the system.

### 7.10 Capillary tube

It consists of a piece of reduced cross section copper tubing located between the condenser and the evaporator, acting as a metering device to reduce the pressure of the refrigerant. Reduction of pressure is a design function to achieve optimum temperature reached within the evaporator: the smaller the capillary tube outlet pressure, the lower the evaporation temperature.

The length and interior diameter of the capillary tubing is accurately sized to establish the performance of the dryer; no maintenance or adjustment is necessary.

### 7.11 Alu-Dry module

The heat exchanger module houses the air-to-air, the air-to-refrigerant heat exchangers and the demister type condensate separator. The counter flow of compressed air in the air-to-air heat exchanger ensures maximum heat transfer. The generous cross section of flow channel within the heat exchanger module leads to low velocities and reduced power requirements. The generous dimensions of the air-to-refrigerant heat exchanger plus the counter flow gas flow allows full and complete evaporation of the refrigerant (preventing liquid return to the compressor). The high efficiency condensate separator is located within the heat exchanger module. No maintenance is required and the coalescing effect results in a high degree of moisture separation.

### 7.12 Hot gas by-pass valve

This valve injects part of the hot gas (taken from the discharge side of the compressor) in the pipe between the evaporator and the suction side of the compressor, keeping the evaporation temperature/pressure constant at approx. +2 °C. This injection prevents the formation of ice inside the dryer evaporator at every load condition.



#### ADJUSTMENT

The hot gas by-pass valve is adjusted during the manufacturing testing phase. As a rule no adjustment is required; anyway if it is necessary the operation must be carried out by an experienced refrigerating engineer.

#### WARNING

the use of ¼" Schrader service valves must be justified by a real malfunction of the refrigerating system. Each time a pressure gauge is connected, a part of refrigerant is exhausted. Without compressed air flow through the dryer, rotate the adjusting screw (position A on the drawing) until the following value is reached:

Hot gas setting : R407C pressure 65.3 psig (+1.45 / -0 psi) [4.5 barg (+0.1 / -0 bar)]

**EGRD 600 – 1254**

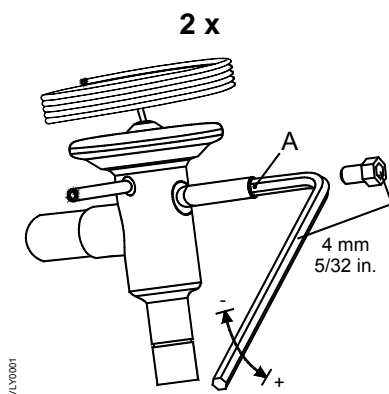

**EGRD 1552 – 2900**

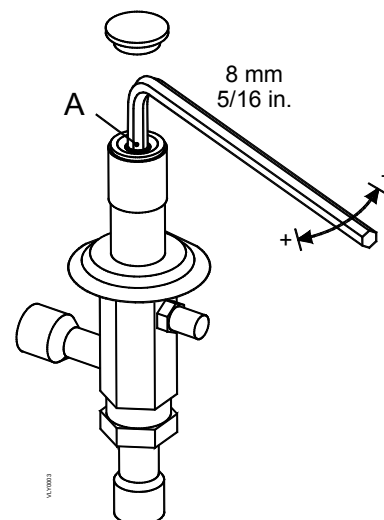

### 7.13 Refrigerant pressure switches LPS – HPS

As operation safety and protection of the dryer a series of pressure switches are installed in the gas circuit.

**LPS :** Low-pressure protection device on the suction side of the compressor, trips if the pressure drops below the pre-set value. The values are automatically reset when the nominal conditions are restored.

Calibrated pressure :        R 407 C   Stop 24.7 psig (1.7 barg) - Restart 39.2 psig (2.7 barg)

**HPS :** This high-pressure controller device, located on the discharge side on the compressor, is activated when the pressure exceeds the pre-set value. It features a manual-resetting button mounted on the controller itself.

Calibrated pressure :        R 407 C   Stop 435 psig (30 barg) - Manual reset P<334 psi (P<23 bar)

### 7.14 Compressor crankcase heater

At low temperatures oil can more easily be mixed with the refrigerant gas. So, when the compressor starts, oil can be drawn into the refrigeration circuit and liquid hammering could occur.

To prevent this, an electrical resistance heater is installed in the suction side of the compressor. When the system is powered and the compressor is not running, this heater keeps the oil at the correct temperature.

This heater is controlled by a thermo switch which prevents overheating the oil.

**NOTE :** The heater must be powered at least a couple of hours before the start up of the refrigeration compressor.

7.15 Electronic instrument DMC24

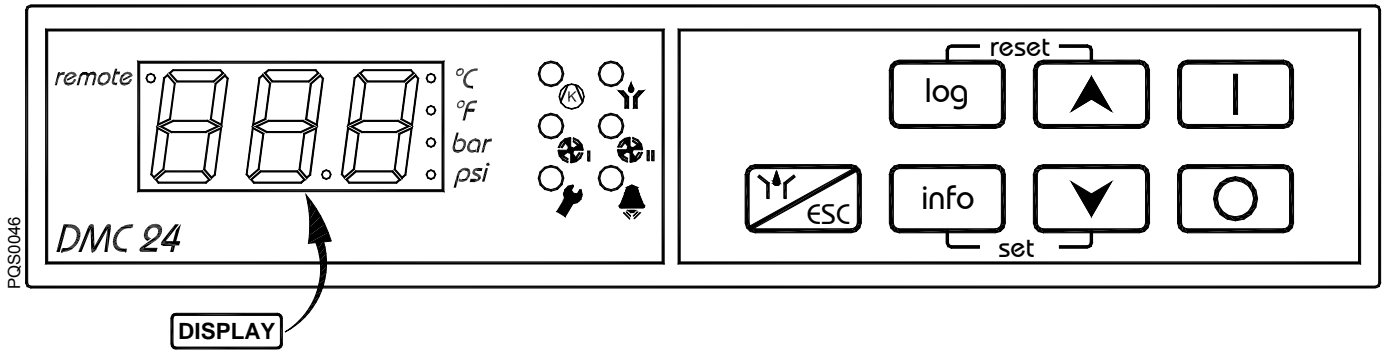

- LED**
- (K) Compressor ON – green
  - Y Drain ON – green
  - ⊕<sub>I</sub> Fan 1 ON – green
  - ⊕<sub>II</sub> Fan 2 ON – green
  - W Service warning – orange
  - A Alarm – red
  - remote ○ Remote control enabled
  - °C Temperature in °C
  - °F Temperature in °F
  - bar Pressure in barg
  - psi Pressure in psig

- BUTTON**
- I ON
  - O OFF
  - ↑ Increase
  - ↓ Decrease
  - log Log
  - info Info menu
  - Y ESC Drain test / ESC
  - info ↓ Set menu on
  - log ↑ Reset alarms and/or service

The DMC24 controls all the operations, alarms and dryer operation set-up. The display and the leds show all the operating conditions.

Led ○ (K) shows that the compressor is ON.



The operation of the fans is indicated by the leds ○ ⊕<sub>I</sub> and ○ ⊕<sub>II</sub>.

During normal operation the display shows the DewPoint temperature.

### 7.15.1 How to switch on the dryer

When the unit is powered the display shows **OFF**.

The condensate drain test is always active through button .

Press  for at least 2 seconds to start the dryer: if the compressor has been shut down for enough time, it will start up immediately; otherwise the display will show the countdown of the seconds before the compressor starts up again, and the led  flashes (max delay 5 minutes).





### 7.15.2 How to switch off the dryer

From any menu press  for at least 2 seconds. The display shows **OFF**.

### 7.15.3 How to display the operating parameters – INFO Menu

The info menu shows the dynamic operating parameters of the dryer.



With the dryer ON and not in other menus, press  for at least 1 second to enter the info menu.

Access to the info menu is confirmed by message **t 1** on the display (first parameter of the menu). Use the arrows  and  to move to the following/previous. Press  to show the value of the selected parameter. Press  again to return to the list of displayable parameters.

Press  to exit info menu (if no button is pressed after 2 minutes the menu is exited automatically).



Info	Description
<b>t 1</b>	T1 - Temperature probe T1 – DewPoint
<b>t 2</b>	T2 – Temperature probe T2 – Air IN
<b>t 3</b>	T3 – Temperature probe T3 – compressor suction
<b>t 4</b>	T4 – Temperature probe T4 – compressor discharge
<b>HP</b>	HP – condensing pressure HP
<b>HrS</b>	HrS – total hours of operation
<b>SrV</b>	SrV – hours until next service

**Note :** The temperatures are displayed in °C or °F (led  or  is lighted).

Pressure is displayed in barg or psig (led  or  is lighted).



The total hours of operation and the hours until the next service are shown in the field 0...999 hours and in thousands of hours from 01.0 hours on (example : if the display shows number 35 it means 35 hours; if the display shows number 3.5 it means 3500 hours).

**7.15.4 How a service warning is displayed**

A service warning is an unusual event that must recall the attention of operators/maintenance technicians. Generally it does not stop the dryer (except for a high DewPoint parameter that can be set to stop the dryer). When the service warning is active the led  flashes. If the service warning is memorized (it tripped but then it switched off by itself) led  is lighted.

In both cases the display shows the DewPoint temperature and the service warnings that are active or not active but that have not yet been reset.

Service warnings are not automatically reset (except for *drn* that can be set in auto-reset).

To **RESET** the service warning press the buttons   simultaneously for 3 seconds. Only the memorized service warning will be reset, whereas the service warning are still engaged will remain displayed and the led  flashes.



**NOTE: the operator/maintenance technician must inspect the dryer and verify/solve the problem that generated the service warning.**

Service Warning	Description
<i>PF 1</i>	PF1 - Probe 1 Failure : failure temperature probe 1
<i>PF 2</i>	PF2 - Probe 2 Failure : failure temperature probe 2
<i>PF 3</i>	PF3 - Probe 3 Failure : failure temperature probe 3
<i>HdP</i>	HdP - High DewPoint: DewPoint too high, higher than the HdA value set.
<i>LdP</i>	LdP - Low DewPoint : DewPoint too low Set T1< -1°C (30°F) delay 5 minutes / Reset T1> 0°C (32°F)
<i>drn</i>	drn - Drainer : condensate drainer failure (opening of contact DRN – if electronic level drainer is installed – see electric diagram)
<i>SrV</i>	SrV - Service : maintenance service time expired SrV
<i>dt</i>	dt - Discharge Temperature : compressor discharge temperature (probe T4) beyond normal values, but within safety limits Set T4> 90°C (194°F) delay 3 minutes / Reset T4< 85°C (185°F)
<i>HCP</i>	HCP - High Condensing Pressure : condensing pressure (transducer BHP) beyond normal values, but within safety limits Set HP> 28barg (406psig) delay 3 minutes / Reset HP< 25barg (363psig)

**NOTE: with dryer ON, but without compressed air pressure, the drainer failure notice *drn* may appear.**



### 7.15.5 How an alarm is displayed

The alarm is an unusual event that always causes the dryer to switch OFF for the safety of the machine and the operators.

When the alarm is active the led  flashes. If the alarm is memorized (it tripped but then it switched off by itself) led  is lighted (dryer stay OFF in any case).

When the led  flashes the message **OFF** and the active alarm/s appear in sequence on the display.

When the led  is lighted, the message **OFF** and the alarm/s that tripped and require to be reset appear in sequence on the display.

The alarms are not automatically reset. To **RESET** the alarm the led  must be lighted and the buttons   must be pressed simultaneously for at least 3 seconds.

The dryer does not start up automatically after the alarms have been reset.





**NOTE: the operator/maintenance technician must inspect the dryer and verify/solve the problem that generated the service warning.**

Alarm	Description
<b>HP</b>	HP - High Pressure : the refrigerant high pressure safety pressure switch HPS tripped (note : the pressure switch has a reset button)
<b>LP</b>	LP - Low Pressure : the refrigerant low pressure safety pressure switch LPS tripped
<b>CO<sub>n</sub></b>	CO <sub>n</sub> - Compressor : the compressor's protections and/or the reverse phase protector RPP tripped
<b>FA<sub>n</sub></b>	FA <sub>n</sub> - Fan : the fan protections tripped
<b>Hdt</b>	Hdt - High Discharge Temperature : compressor discharge temperature beyond the safety limit Set T4> 100°C (212°F) delay 1 minute / Reset T4< 90°C (194°F)
<b>ICE</b>	ICE - ICE / freezing : temperature inside the exchanger (probe T1) is too low and causes the condensate to freeze. Set T1< -3°C (27°F) delay 1 minute / Reset T1> 0°C (32°F)
<b>LCP</b>	LCP - Low Condensing Pressure : condensing pressure too low
<b>PF4</b>	PF4 - Probe 4 Failure : failure probe 4
<b>PFP</b>	PFP - Probe Pressure Failure : failure condensing pressure trasducer BHP

### 7.15.6 How to show the alarm memory – LOG Menu

The log menu is the list of the last 10 alarms (only alarms, not service warning). They appear in chronological order (LIFO logic).

With dryer ON or OFF and not in other menus, press  for at least 1 second to enter the log menu.

Access to the log menu is confirmed by message **L01** (L01) on the display (first parameter of menu). Use the arrows  and  to move to following/previous (L01 ... L10). Press  to show the selected log value. Alternatively the parameter that generated the alarm and the hours of operation of the machine when the alarm tripped are shown. Press  again to return to the log list.

Press  to exit log menu (if no button is pressed after 2 minutes the menu is exited automatically).

**NOTE:** an empty position in the log list is displayed by the message **no n**.

### 7.15.7 How to control dryer with remote control

The DMC24 can be easily controlled using 2 digital inputs connected to terminals 1, 2 and 3 (see electric diagram).

Close the contact between the terminals 2 and 3 to enable the remote control, the led *remote*  turns on and it is no longer possible to switch the dryer ON or OFF from local panel (the condensate drain test is possible and access to info and log menus).

Having contact between terminals 2 and 3 closed, close the second contact between the terminals 1 and 2 to switch ON the dryer. Open the contact between the terminals 1 and 2 to switch OFF the dryer.



**Use dry contacts only (potential free) suitable for low voltage. Assure an adequate isolation of potentially dangerous powered parts.**



**CAUTION:**

**AUTO-RESTART / REMOTE ON-OFF**

**THE DRYER MAY POWER UP WITHOUT BEING ACTED UPON.**

**THE USER WILL BE RESPONSIBLE FOR THE INSTALLATION OF PROPER PROTECTIONS FOR POSSIBLE SUDDEN POWER RESTORATION TO THE DRYER.**

### 7.15.8 Operation of the failure / alarm dry contact (potential free)

The DMC24 is equipped with a dry contact (potential free) to display failure and/or alarm conditions.

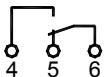

Dryer powered and no service warning or alarm (active and not yet reset) displayed.

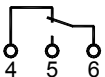

Dryer not powered or service warning or alarm (active and not yet reset) displayed.

### 7.15.9 Connection to serial line

The DMC24 can be connected to a supervision serial line, remote control or download of log file (memory) of alarms.



Contact your distributor or service centre for more information.



### 7.15.10 How to change operating parameters – SETUP Menu





The setup menu can be used to change the dryer's operating parameters.



Only qualified personnel must be allowed to access to the setup menu. The manufacturer is not responsible for malfunctioning or failure due to modification to the operating parameters.

With dryer ON or OFF and not in other menus, simultaneously press buttons   for at least 5 seconds to enter the setup menu.

Access to the info menu is confirmed by message **ton** on the display (first parameter of menu). Use arrows  and  to move to following/previous one.

Keep  pressed to display the value of the selected parameter and use arrows  and  to change the value. Release the button  to confirm the value and skip to following parameter.

Press  to exit setup menu (if no button is pressed after 2 minutes the menu is exited automatically).

ID	Description	Limits	Resolution	Standard setup
<b>ton</b>	Ton – drain time ON : time ON condensate drain valve <b>00 = Electronic drainer installed</b>	00 ... 20 sec	1 sec	00
<b>toF</b>	ToF - drain time OFF : pause time for condensate drain valve	1 ... 20 min	1 min	1
<b>HdA</b>	HdA - High DewPoint Alarm : Alarm threshold for a high DewPoint (the alarm disappears when the temperature drop 1°C / 2°F below alarm point)	0.0...25.0 °C or 32 ... 77 °F	0.5 °C or 1 °F	20 or 68
<b>Hdd</b>	Hdd - High DewPoint Delay : high DewPoint alarm enable delay	01 ... 20 minutes	1 min	15
<b>HdS</b>	HdS - High DewPoint alarm STOP : select if high DewPoint alarm stops dryer (YES) or does not stop dryer (nO)	YES ... nO	-	nO
<b>SrV</b>	SrV - Service Setting: setting of service warning timer. 00 = service warning timer disabled.	0.0 ... 9.0 (x 1000) hours	0.5 (x1000) hours	8.0
<b>SCL</b>	SCL - Scale: display scale of temperatures and pressure. (Note : setting °C = temperature in °C and pressure in bar; setting °F = temperature in °F and pressure in psi)	°C ... °F	-	°C
<b>AS</b>	AS - Auto Restart : automatic re-start at power supply. YES = at power supply dryer starts up again automatically (if it was ON) nO = at power supply dryer is always OFF	YES ... nO	-	nO
<b>Ard</b>	Ard - Auto Reset service drain : automatic reset of service drain YES = automatic reset at normal conditions nO = manual reset required	YES ... nO	-	YES
<b>IPA</b>	IPA - IP Address : selection of IP address to use in serial connection line	1 ... 255	1	1



**AS = YES - CAUTION -**

**THE DRYER MAY POWER UP WITHOUT BEING ACTED UPON.**

**THE USER WILL BE RESPONSIBLE FOR THE INSTALLATION OF PROPER PROTECTIONS FOR POSSIBLE SUDDEN POWER RESTORATION TO THE DRYER.**

### 7.16 Electronic drainer

This drain consists of a condensate accumulator where a capacitive sensor continuously checking liquid level is placed: as soon as the accumulator is filled, the sensor passes a signal to the electronic control and a diaphragm solenoid valve will open to discharge the condensate. For a complete condensate discharge the valve opening time will be adjusted exactly for each single drain operation. No condensate strainers are installed. No adjusting is required. A service valve is installed before the electronic drain in order to make check and maintenance easily. **At dryer start-up verify that this valve is open.**

#### Control panel

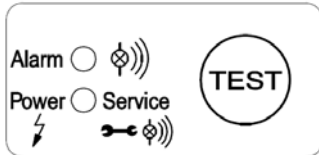

Power / Service Led (green)	ON - ready to work / supplied Blinking – maintenance required
Alarm Led (red)	Blinking – alarm condition
Power+Alarm Led	ON - circuit board defect
TEST Button	Discharge test (keep pushed for 2 seconds)

#### Troubleshooting



**Only qualified personnel should perform troubleshooting and or maintenance operations.**

**Prior to performing any maintenance or service, be sure that :**

- no part of the machine is powered and that it cannot be connected to the mains supply.
- no part of the machine is under pressure and that it cannot be connected to the compressed air system.
- maintenance personnel have read and understand the safety and operation instructions in this manual.

**PLEASE REFER TO INSTRUCTION MANUAL OF ELECTRONIC DRAINER**

## 8 Maintenance, troubleshooting, spare parts and dismantling

### 8.1 Checks and maintenance



Only qualified personnel should perform troubleshooting and or maintenance operations.

Prior to performing any maintenance or service, be sure that :



- no part of the machine is powered and that it cannot be connected to the mains supply.
- no part of the machine is under pressure and that it cannot be connected to the compressed air system.
- maintenance personnel have read and understand the safety and operation instructions in this manual.



Before attempting any maintenance operation on the dryer, shut it down and wait at least 30 minutes. components can reach high temperature during operation. Avoid contact until system or component has dissipated heat.

#### Daily



- Verify that the DewPoint displayed on the electronic instrument is correct.
- Check the proper operation of the condensate drain systems.
- Verify the condenser for cleanliness (Air-Cooled).

#### Every 200 hours or monthly



- With an air jet (max. 2 bar / 30 psig) blowing from inside towards outside clean the condenser; repeat this operation blowing in the opposite way; be careful not to damage the aluminum fins of the cooling package (Air-Cooled)



- Close the manual condensate drain valve, unscrew the strainer (if installed) and clean it with compressed air and brush. Reinstall the strainer properly tight, and then open the manual valve.
- At the end, check the operation of the machine

#### Every 1000 hours or yearly



- Verify for tightness all the screws of the electric system and that all the “Disconnects-Tabs” type connections are in their proper position inspect unit for broken, cracked or bare wires.
- Inspect refrigerating circuit for signs of oil and refrigerant leakage.
- Measure and record amperage. Verify that readings are within acceptable parameters as listed in specification table.
- Inspect flexible hoses, and replace if necessary.
- At the end, check the operation of the machine.

#### Every 8000 hours



- Replace Electronic drainer service unit

8.2 Troubleshooting



Only qualified personnel should perform troubleshooting and or maintenance operations.



Prior to performing any maintenance or service, be sure that :



- no part of the machine is powered and that it cannot be connected to the mains supply.
- no part of the machine is under pressure and that it cannot be connected to the compressed air system.
- maintenance personnel have read and understand the safety and operation instructions in this manual.













Before attempting any maintenance operation on the dryer, shut it down and wait at least 30 minutes. Some components can reach high temperature during operation. Avoid contact until system or component has dissipated heat.

SYMPTOM	POSSIBLE CAUSE - SUGGESTED ACTION
◆ The dryer doesn't start.	<ul style="list-style-type: none"> <li>⇒ Verify that the system is powered.</li> <li>⇒ Verify the electric wiring.</li> <li>⇒ Blow of fuse (see FU1/FU2/FU4 on the electric diagram) of the auxiliary circuit - replace it and check the proper operation of the dryer.</li> <li>⇒ DMC24 - The led  is lighted - see specific point.</li> </ul>
◆ The compressor doesn't work.	<ul style="list-style-type: none"> <li>⇒ Activation of the compressor internal thermal protection - wait for 30 minutes, then retry.</li> <li>⇒ Verify the electric wiring.</li> <li>⇒ DMC24 - Internal delay device – the display shows the seconds before start-up.</li> <li>⇒ DMC24 - The led  is lighted - see specific point.</li> <li>⇒ If the compressor still doesn't work, replace it.</li> </ul>
◆ Condenser's fan doesn't work (Air-Cooled).	<ul style="list-style-type: none"> <li>⇒ Verify the electric wiring.</li> <li>⇒ Fan power contactor (see KV1/KV2 on the electric diagram) is faulty - replace it.</li> <li>⇒ DMC24 - The led  is lighted - see specific point.</li> <li>⇒ There is a leak in the refrigerant circuit - contact a refrigeration engineer.</li> <li>⇒ If the fan still doesn't work, replace it.</li> </ul>
◆ DewPoint too high.	<ul style="list-style-type: none"> <li>⇒ The dryer doesn't start - see specific point.</li> <li>⇒ The DewPoint probe doesn't correctly detect the temperature - ensure the sensor is pushed into the bottom of probe well.</li> <li>⇒ The Compressor doesn't work - see specific point.</li> <li>⇒ The ambient temperature is too high or the room aeration is insufficient - provide proper ventilation (Air-Cooled).</li> <li>⇒ The inlet air is too hot - restore nominal conditions.</li> <li>⇒ The inlet air pressure is too low - restore nominal conditions.</li> <li>⇒ The inlet air flow rate is higher than the rate of the dryer - reduce the flow rate - restore nominal conditions.</li> <li>⇒ The condenser is dirty - clean it (Air-Cooled)</li> <li>⇒ The condenser fan doesn't work - see specific point (Air-Cooled).</li> <li>⇒ The cooling water is too hot - restore nominal conditions (Water-Cooled).</li> <li>⇒ The cooling water flow is insufficient - restore nominal conditions (Water-Cooled).</li> <li>⇒ The dryer doesn't drain the condensate - see specific point.</li> <li>⇒ The hot gas by-pass valve is out of setting - contact a refrigeration engineer to restore nominal setting.</li> <li>⇒ There is a leak in the refrigerant circuit - contact a refrigeration engineer.</li> </ul>

SYMPTOM	POSSIBLE CAUSE - SUGGESTED ACTION
◆ Dew Point too low	<ul style="list-style-type: none"> <li>⇒ The fan is always on – verify the correct operation of the fan power contactor (see KV1/KV2 on the electric diagram) and/or of pressure transducer (see BHP on the electric diagram) – (Air-Cooled).</li> <li>⇒ Ambient temperature is too low - restore nominal conditions (Air-Cooled).</li> <li>⇒ The hot gas by-pass valve is out of setting - contact a refrigeration engineer to restore nominal setting.</li> </ul>
◆ Excessive pressure drop within the dryer.	<ul style="list-style-type: none"> <li>⇒ The dryer doesn't drain the condensate - see specific point.</li> <li>⇒ The DewPoint is too low - the condensate is frost and blocks the air - see specific point.</li> <li>⇒ Check for throttling the flexible connection hoses.</li> </ul>
◆ The dryer doesn't drain the condensate	<ul style="list-style-type: none"> <li>⇒ The condensate drain service valve is closed - open it.</li> <li>⇒ Verify the electric wiring.</li> <li>⇒ The DewPoint is too low - the condensate is frost and blocks the air - see specific point.</li> <li>⇒ Inlet compressed air pressure is too low and condensate is not drained – restore nominal conditions.</li> <li>⇒ Electronic drainer is not operating correctly (see paragraph 7.16).</li> </ul>
◆ The dryer continuously drains condensate.	<ul style="list-style-type: none"> <li>⇒ Electronic drainer is dirty (see paragraph 7.16).</li> </ul>
◆ Water within the line.	<ul style="list-style-type: none"> <li>⇒ The dryer doesn't start - see specific point.</li> <li>⇒ <b>If installed</b> - Untreated air flows through the by-pass unit - close the by-pass.</li> <li>⇒ The dryer doesn't drain the condensate - see specific point.</li> <li>⇒ DewPoint too high - see specific point.</li> </ul>
◆ HPS high pressure switch has been activated.	<ul style="list-style-type: none"> <li>⇒ Check which of the following has caused the activation :               <ol style="list-style-type: none"> <li>1. The ambient temperature is too high or the room aeration is insufficient - provide proper ventilation (Air-Cooled).</li> <li>2. The condenser is dirty - clean it (Air-Cooled).</li> <li>3. The condenser fan doesn't work - see specific point (Air-Cooled).</li> <li>4. The cooling water is too hot - restore nominal conditions (Water-Cooled).</li> <li>5. The cooling water flow is insufficient - restore nominal conditions (Water-Cooled).</li> </ol> </li> <li>⇒ Reset the pressure switch pressing the button on the controller itself - verify the dryer for correct operation.</li> <li>⇒ HPS pressure switch is faulty - contact a refrigeration engineer to replace it.</li> </ul>
◆ LPS low pressure switch has been activated.	<ul style="list-style-type: none"> <li>⇒ There is a leak in the refrigerating fluid circuit - contact a refrigeration engineer.</li> <li>⇒ The pressure switch reset automatically when normal conditions are restored - check the proper operation of the dryer.</li> </ul>

<b>SYMPTOM</b>	<b>POSSIBLE CAUSE - SUGGESTED ACTION</b>
◆ Compressor discharge temperature too high.	⇒ Check which of the following has caused the failure : <ol style="list-style-type: none"> <li>1. Excessive thermal load – restore nominal conditions.</li> <li>2. The inlet air is too hot - restore nominal conditions.</li> <li>3. The ambient temperature is too high or the room aeration is insufficient - provide proper ventilation (Air-Cooled).</li> <li>4. The condenser unit is dirty - clean it (Air-Cooled).</li> <li>5. The fan doesn't work - see specific point (Air-Cooled).</li> <li>6. The fan is always on – verify proper operation of fan power contactor (see KV1/KV2 on electric diagram) and/or of pressure transducer (see BHP on electric diagram) – (Air-Cooled).</li> <li>7. The hot gas by-pass valve requires re-adjusting – contact a specialized technician to restore nominal setting.</li> <li>8. The temperature of the cooling water is too low – restore nominal conditions (Water-Cooled).</li> <li>9. The cooling water flow adjusting valve requires re-adjusting - contact a specialized technician to restore nominal setting (Water-Cooled).</li> <li>10. Refrigerant gas leak - contact a refrigeration engineer.</li> </ol>
◆ Condensing pressure too high	⇒ Check which of the following has caused the failure : <ol style="list-style-type: none"> <li>1. The ambient temperature is too high or the room aeration is insufficient - provide proper ventilation (Air-Cooled).</li> <li>2. The condenser unit is dirty - clean it (Air-Cooled).</li> <li>3. The fan doesn't work - see specific point (Air-Cooled).</li> <li>4. The temperature of the cooling water is too hot – restore nominal conditions (Water-Cooled).</li> <li>5. Cooling water flow is not sufficient – restore nominal conditions (Water-Cooled).</li> </ol>
◆ Condensing pressure too low	⇒ Check which of the following has caused the failure : <ol style="list-style-type: none"> <li>1. The fan is always on – verify proper operation of fan power contactor (see KV1/KV2 on electric diagram) and/or of pressure transducer (see BHP on electric diagram) – (Air-Cooled).</li> <li>2. Ambient temperature is too low - restore nominal conditions (Air-Cooled).</li> <li>3. Air flows through the condenser even with fan off – protect dryer against wind or external air flows (not caused by dryer's fan) (Air-Cooled).</li> <li>4. The temperature of the cooling water is too low – restore nominal conditions (Water-Cooled).</li> <li>5. The cooling water flow adjusting valve requires re-adjusting - contact a specialized technician to restore nominal setting (Water-Cooled).</li> <li>6. Refrigerant gas leak - contact a refrigeration engineer.</li> <li>7. Compressor does not work – see specific point.</li> </ol>

SYMPTOM	POSSIBLE CAUSE - SUGGESTED ACTION
<p>◆ Electronic instrument DMC24</p> <p>The led  is on or flashes.</p>	<p>⇒ With  led flashing : one or more alarms are active and the display shows <b>OFF</b> and the active alarms.</p> <p>⇒ With  led lighted : one or more alarms are waiting to be reset and the display shows <b>OFF</b> and the alarms that are no longer active but not yet reset.</p> <p>⇒ The alarms are displayed with the following messages :</p> <ol style="list-style-type: none"> <li>1. <b>HP</b> : HP - HPS pressure switch tripped (refrigerant high pressure) for condensing pressure too high - see specific paragraph (NOTE : when problem is solved press reset key on HPS pressure switch).</li> <li>2. <b>LP</b> : LP - LPS pressure switch tripped (low pressure) due to refrigerant pressure too low - see specific paragraph.</li> <li>3. <b>Con</b> : Con – <b>during first startup</b> – power phases of compressor are not connected properly (see RPP on the electric diagram) – Change rotating direction swapping two phases of the power supply of dryer. These changes have to be done only by a qualified electrician. <b>DO NOT BY PASS RPP PROTECTION: BY OPERATING THE MACHINE IN WRONG ROTATING DIRECTION, THE COMPRESSOR WILL FAIL IMMEDIATELY AND THE WARRANTY WILL BE VOIDED.</b></li> <li>4. <b>Con</b> : Con – one phase of power supply of dryer is missing (see RPP on the electric diagram) – restore the missing phase.</li> <li>5. <b>Con</b> : Con – Reverse Phase Protector (RPP) is faulty – replace it.</li> <li>6. <b>Con</b> : Con – electric protection of compressor tripped (see Q1/QC1 on the electric diagram)– reset and verify the dryer’s proper operation.</li> <li>7. <b>Con</b> : Con - <b>if installed</b> - thermal protection inside the compressor tripped (see MC1 on wiring diagram – wait 30 minutes and try again.</li> <li>8. <b>FAn</b> : FAn - electric protection of fan tripped (see QV1 on the electric diagram) - reset and verify the dryer’s proper operation (Air-Cooled).</li> <li>9. <b>FAn</b> : FAn – thermal protection inside the fan/s tripped (see MF on wiring diagram – wait 30 minutes and try again (Air-Cooled).</li> <li>10. <b>Hdt</b> : Hdt – compressor discharge temperature protection tripped due to very high temperature (probe T4) – see specific paragraph.</li> <li>11. <b>ICE</b> : ICE – temperature inside exchanger (probe T1) too low – DewPoint is too low - see specific paragraph.</li> <li>12. <b>LCP</b> : LCP - condensing pressure too low – see specific paragraph.</li> <li>13. <b>PF4</b> : PF4 – failure temperature probe T4 (compressor discharge) – verify electric wiring and/or replace probe.</li> <li>14. <b>PPF</b> : PFP – failure pressure transducer BHP (condensing pressure) – verify electric wiring and/or replace transducer.</li> </ol> <p><b>NOTE:</b> after solving the problem, the alarms must be reset (press the keys    simultaneously for 3 seconds).</p>

SYMPTOM	POSSIBLE CAUSE - SUGGESTED ACTION
<p>◆ Electronic instrument DMC24</p> <p>The led  is on or flashes.</p>	<p>⇒ With  led flashing: one or more service warnings are active.</p> <p>⇒ With  led lighted: one or more service warnings are waiting to be reset. The display shows the DewPoint temperature and the active or not reset service warning.</p> <p>⇒ The service warnings are displayed with the following messages :</p> <ol style="list-style-type: none"> <li>1. <b>PF1</b> : PF1 – temperature probe failure T1 (DewPoint) – verify electric wiring and/or replace probe.</li> <li>2. <b>PF2</b> : PF2 - temperature probe failure T2 (air IN) – verify electric wiring and/or replace probe.</li> <li>3. <b>PF3</b> : PF3 - temperature probe failure T3 (compressor suction) – verify electric wiring and/or replace probe.</li> <li>4. <b>HdP</b> : Hdp – DewPoint too high (higher than set HdA value) – see specific paragraph.</li> <li>5. <b>LdP</b> : Ldp - DewPoint too low - see specific paragraph.</li> <li>6. <b>drn</b> : drn – the condensate drainer does not work properly (DRN contact open- if electronic drainer is installed) - see specific paragraph.</li> <li>7. <b>SrV</b> : SrV - Service – maintenance notice time expired (parameter SrV) – carry out planned maintenance and reset hour counter.</li> <li>8. <b>dt</b> : dt – compressor supply temperature too high (probe T4) – see specific paragraph.</li> <li>9. <b>HCP</b> : HCP – condensing pressure too high – see specific paragraph.</li> </ol> <p><b>NOTE:</b> after solving the problem, the services must be reset (press the keys   simultaneously for at least 3 seconds).</p>

### 8.3 Maintenance operation on the refrigeration circuit



Maintenance and service on refrigerating systems must be carried out only by certified refrigerating engineers only, according to local rules.

All the refrigerant of the system must be recovered for its recycling, reclamation or destruction.

**Do not dispose the refrigerant fluid in the environment.**

This dryer comes ready to operate and filled with R407C type refrigerant fluid.



In case of refrigerant leak contact a certified refrigerating engineer. Room is to be aired before any intervention.

If is required to re-fill the refrigerating circuit, contact a certified refrigerating engineers.

Refer to the dryer nameplate for refrigerant type and quantity.

Characteristics of refrigerants used:

Refrigerant	Chemical formula	TLV	GWP
R407C - HFC	R32/125/134a (23/25/52) CHF2CF3/CH2F2/CH2FCF3	1000 ppm	1653

### 8.4 Dismantling of the dryer

If the dryer is to be dismantled, it has to be split into homogeneous groups of materials.



Part	Material
Refrigerant fluid	R407C, Oil
Canopy and Supports	Carbon steel, Epoxy paint
Refrigerating compressor	Steel, Copper, Aluminium, Oil
Alu-Dry Module	Aluminium
Condenser Unit	Aluminium, Copper, Carbon steel
Pipe	Copper
Fan	Aluminium, Copper, Steel
Valve	Brass, Steel
Electronic Level Drain	PVC, Aluminium, Steel
Insulation Material	Synthetic rubber without CFC, Polystyrene, Polyurethane
Electric cable	Copper, PVC
Electric Parts	PVC, Copper, Brass



We recommend to comply with the safety rules in force for the disposal of each type of material.

Refrigerant contains droplets of lubrication oil released by the refrigerating compressor.

Do not dispose this fluid in the environment. It has to be discharged from the dryer with a suitable device and then delivered to a collection centre where it will be processed to make it reusable.

**9 Attachments**

**Exploded views – List of components**

- |  |   |
|--|---|
| <p><b>1</b> Alu-Dry module</p> <p><b>1.1</b> Insulation material</p> <p><b>2</b> Refrigerant pressure switch LPS</p> <p><b>4</b> Refrigerant pressure switch HPS</p> <p><b>6</b> Compressor</p> <p><b>7</b> Hot-gas bypass valve</p> <p><b>8</b> Condenser (Air-Cooled)</p> <p><b>9</b> Condenser fan (Air-Cooled)</p> <p><b>10</b> Filter dryer</p> <p><b>11</b> Capillary tube</p> <p><b>13</b> Condensate drain service valve</p> <p><b>17</b> Electronic instrument</p> <p><b>18</b> Condenser (Water-Cooled)</p> <p><b>19</b> Condenser water-regulating valve (Water-Cooled)</p> <p><b>20</b> Refrigerant accumulator</p> <p><b>21</b> Electronic drainer</p> <p><b>22</b> Main switch</p> | <p><b>36</b> Liquid separator</p> <p><b>37</b> Refrigerant pressure transducer</p> <p><b>43</b> Oil separator</p> <p><b>51</b> Front panel</p> <p><b>52</b> Back panel</p> <p><b>53</b> Right lateral panel</p> <p><b>54</b> Left lateral panel</p> <p><b>55</b> Cover</p> <p><b>56</b> Base plate</p> <p><b>58</b> Support beam</p> <p><b>59</b> Support bracket</p> <p><b>60</b> Control panel</p> <p><b>65</b> Condenser filter</p> <p><b>66</b> QE door</p> <p><b>81</b> Flow diagram sticker</p> <p><b>83</b> Refrigerant service valve – H.P. side</p> <p><b>84</b> Refrigerant service valve – L.P. side</p> |
|--|---|

**Electric diagrams – List of components**

- |   |   |
|---|---|
| <p><b>MC1</b> Compressor</p> <p><b>MV1 - 4</b> Condensers fans</p> <p><b>DMC24</b> Electronic instr. DMC24 – Display module</p> <p><b>DMC24MA</b> Electronic instr. DMC24 – Main module</p> <p><b>BT1 - 4</b> Temperature probes</p> <p><b>BHP</b> Refrigerant pressure transducer</p><br><br><p><b>NT1</b> Air-Cooled only</p> <p><b>NT2</b> Verify transformer connection according to power supply voltage</p> <p><b>NT3</b> Jump if not installed</p> <p><b>NT4</b> Provided and wired by customer</p><br><br><p><b>BN</b> Brown</p> <p><b>BU</b> Blue</p> <p><b>BK</b> Black</p> <p><b>YG</b> Yellow / Green</p> | <p><b>LPS</b> Low pressure switch</p> <p><b>HPS</b> High pressure switch</p> <p><b>ELD</b> Electronic drainer</p> <p><b>QS</b> Main switch with door block</p> <p><b>RC</b> Compressor crankcase heater</p> <p><b>RPP</b> Reverse phase protector</p><br><br><p><b>NT5</b> Limit of equipment</p> <p><b>NT6</b> Timed drain output</p> <p><b>NT7</b> Water Cooled only</p><br><br><p><b>OR</b> Orange</p> <p><b>RD</b> Red</p> <p><b>WH</b> White</p> <p><b>WH / BK</b> White / Black</p> |
|---|---|

9.1 Dryers dimensions

9.1.1 EGRD 600 – 1254

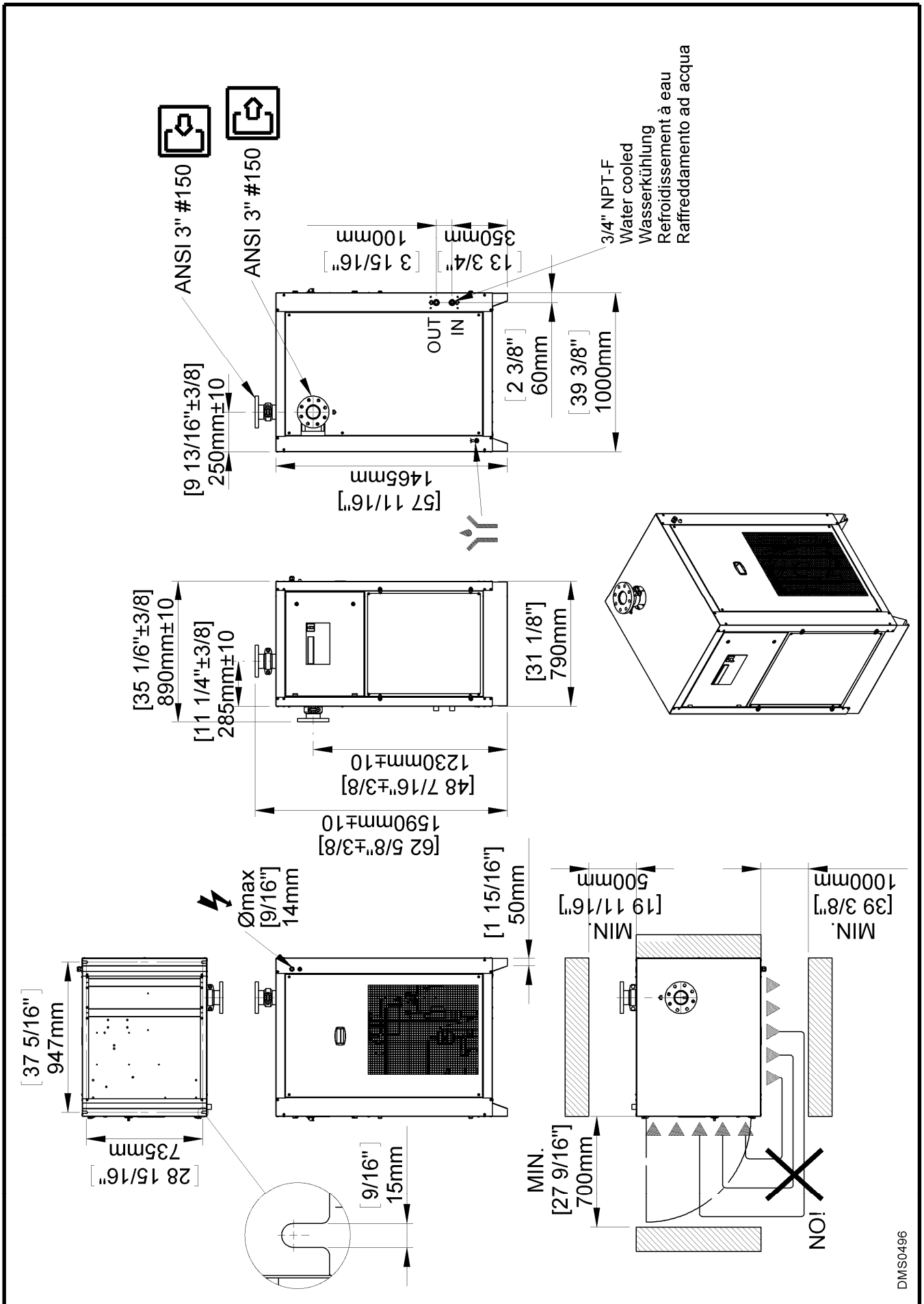

9.1.2 EGRD 1552 – 2900

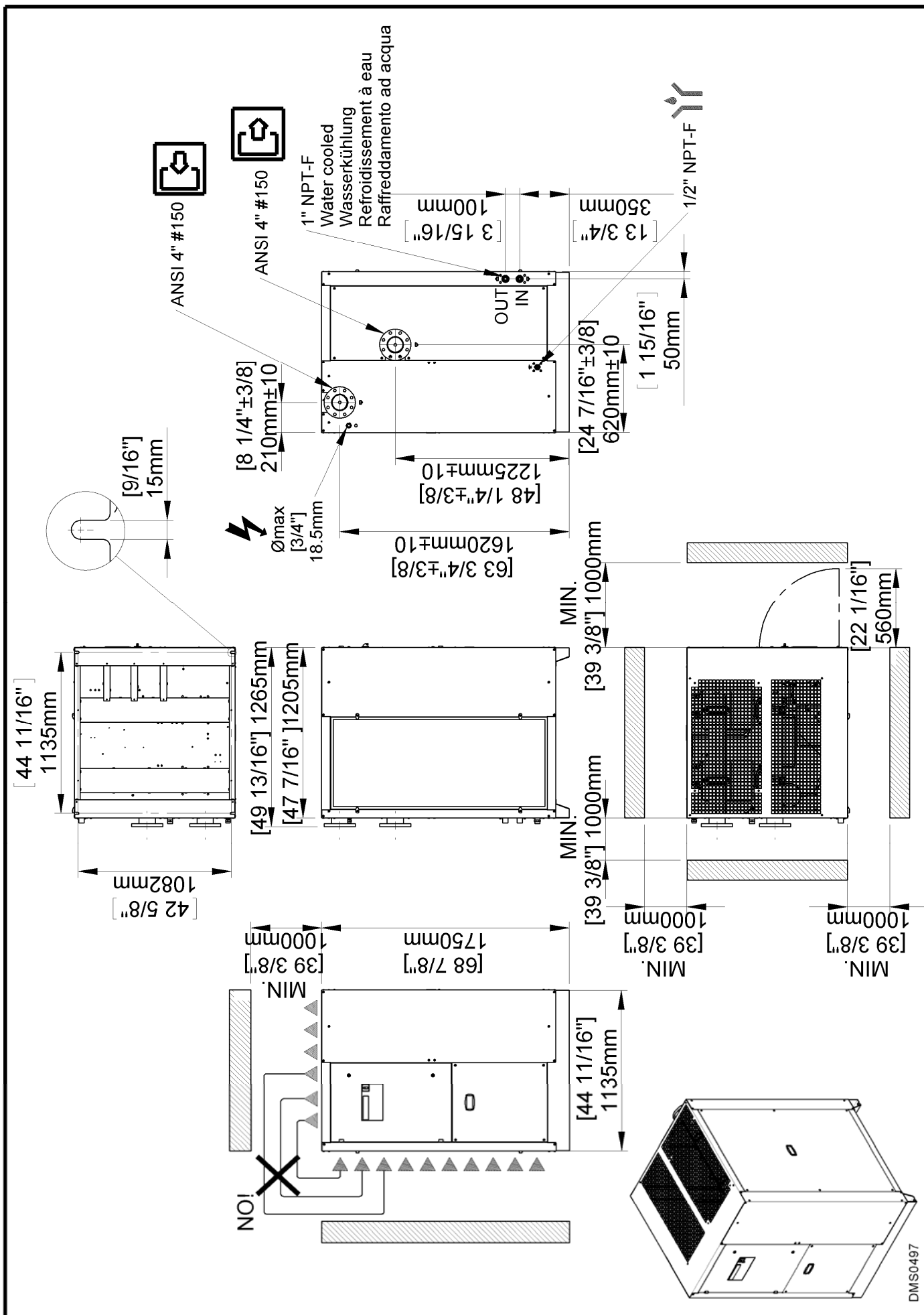

9.2 Exploded views

9.2.1 EGRD 600 – 1254 Air Cooled

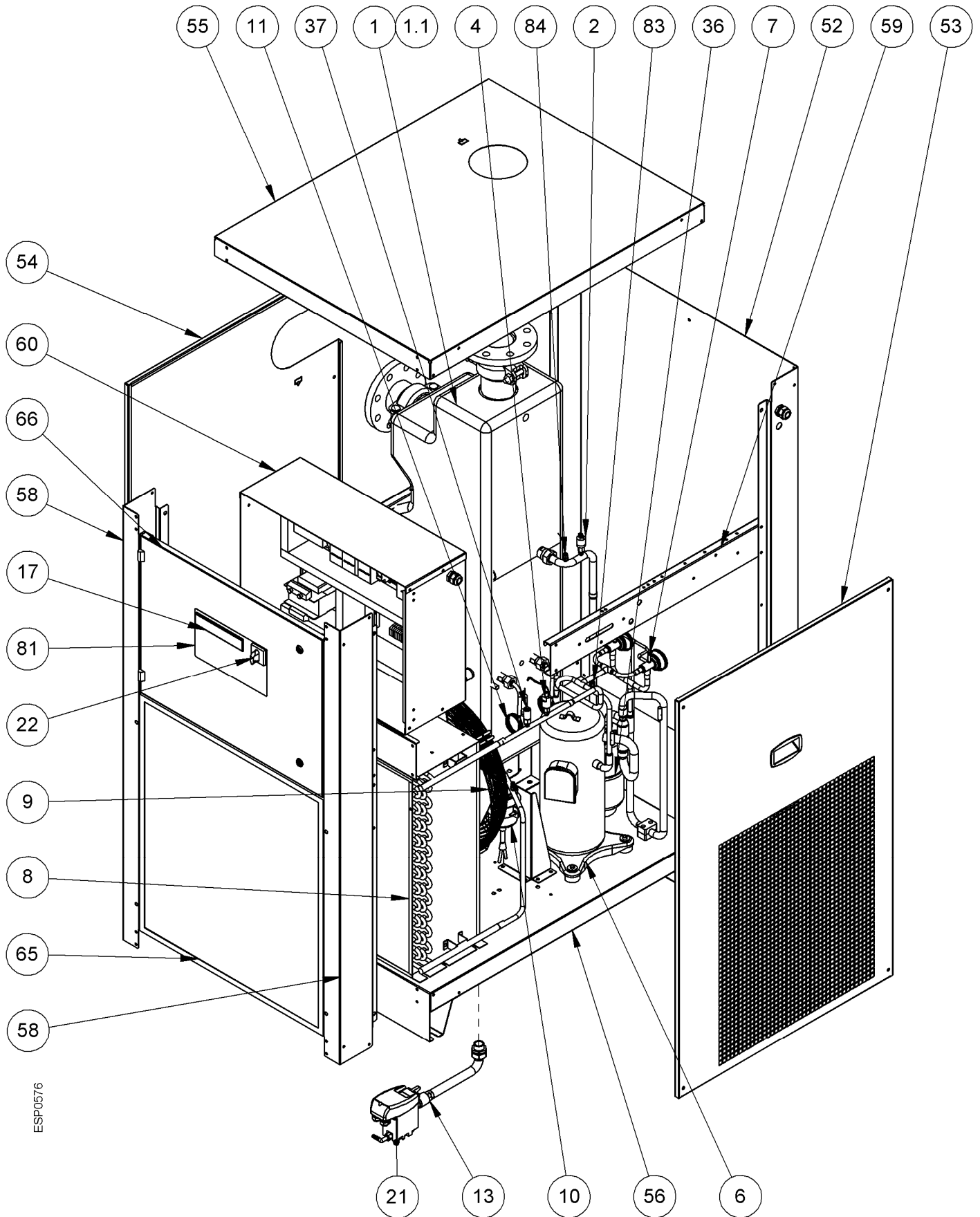

ESP0576

9.2.2 EGRD 600 – 1254 Water Cooled

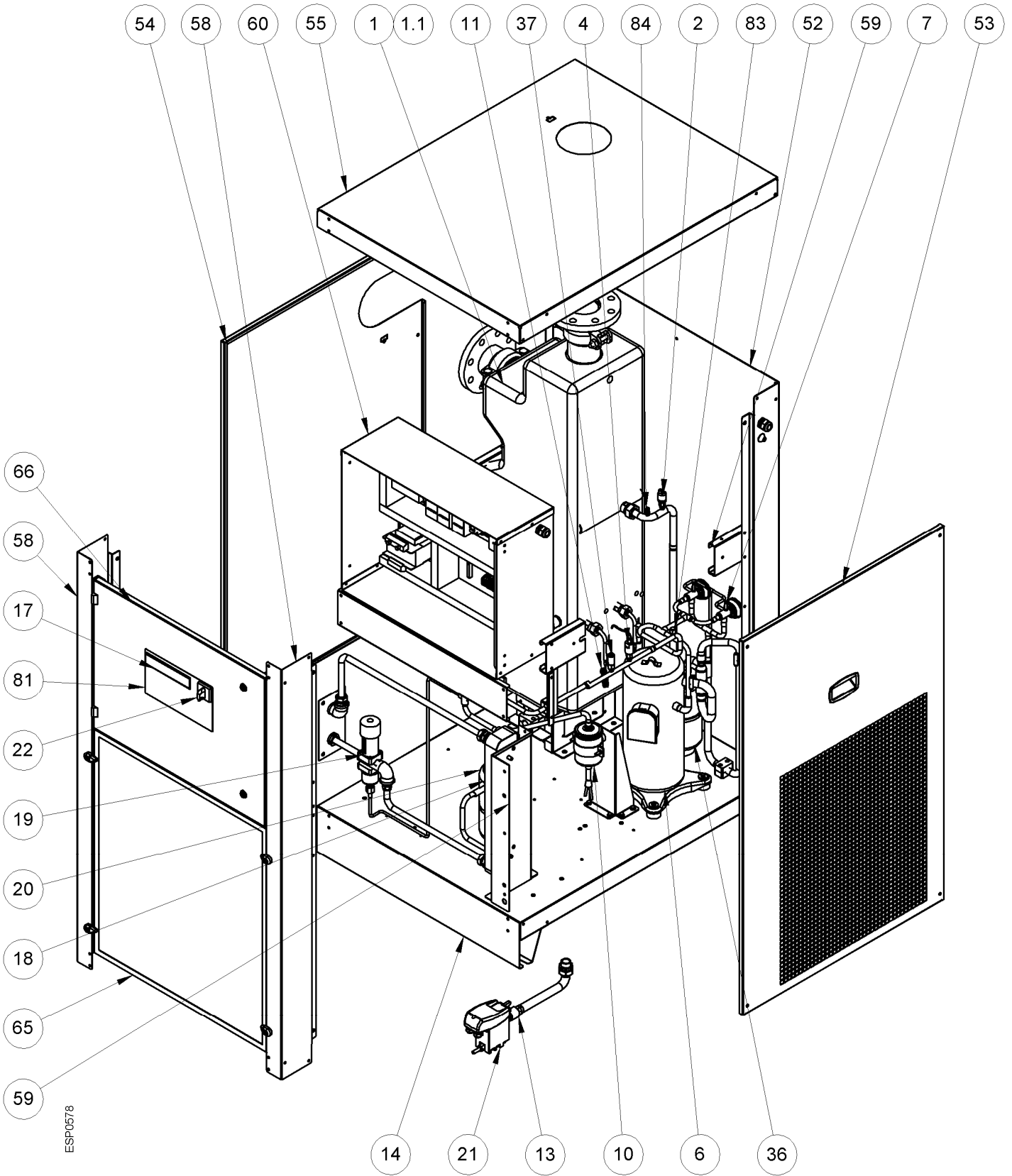

9.2.3 EGRD 1552 – 2900 Air Cooled

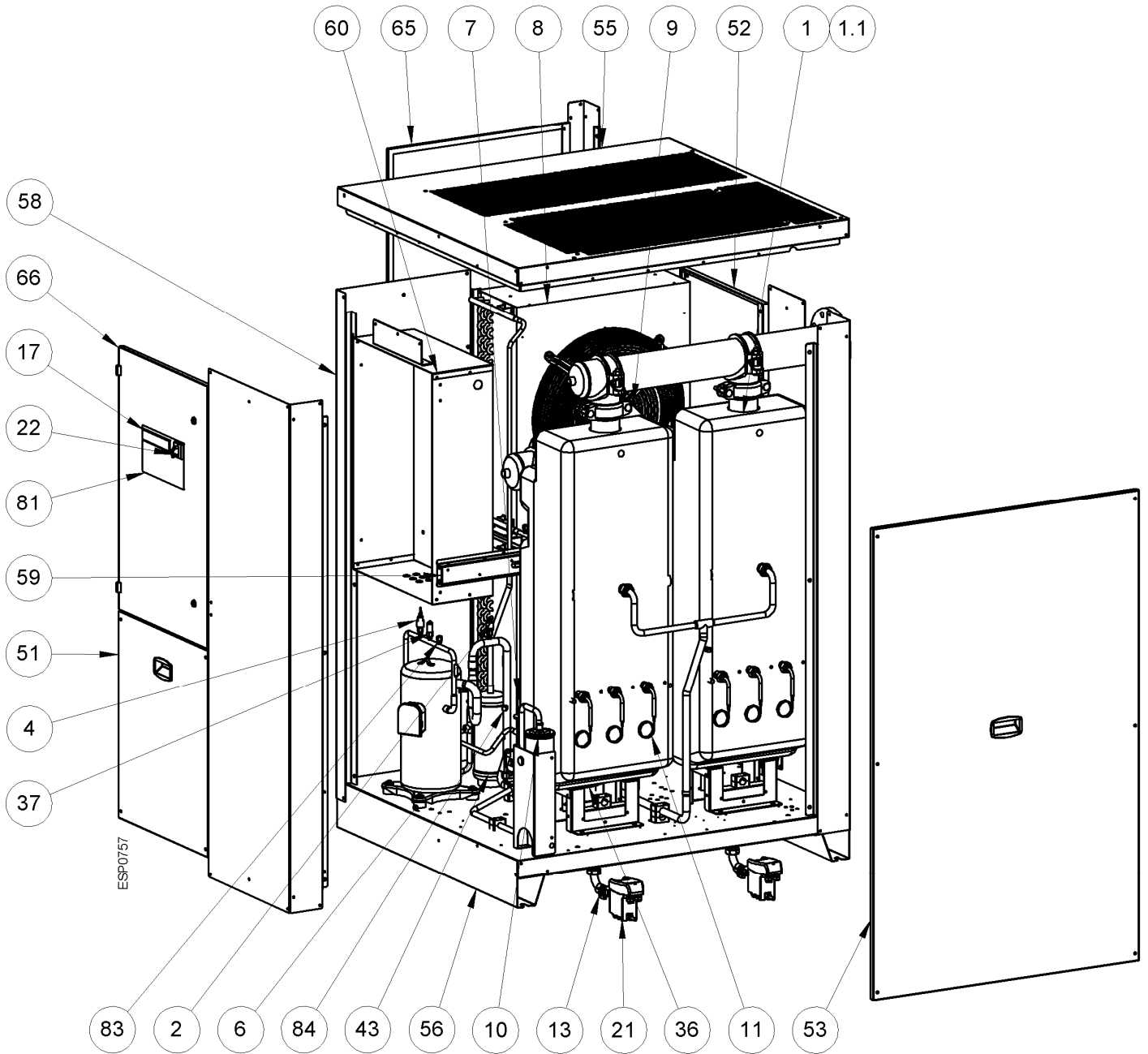

9.2.4 EGRD 1552 – 2900 Water Cooled

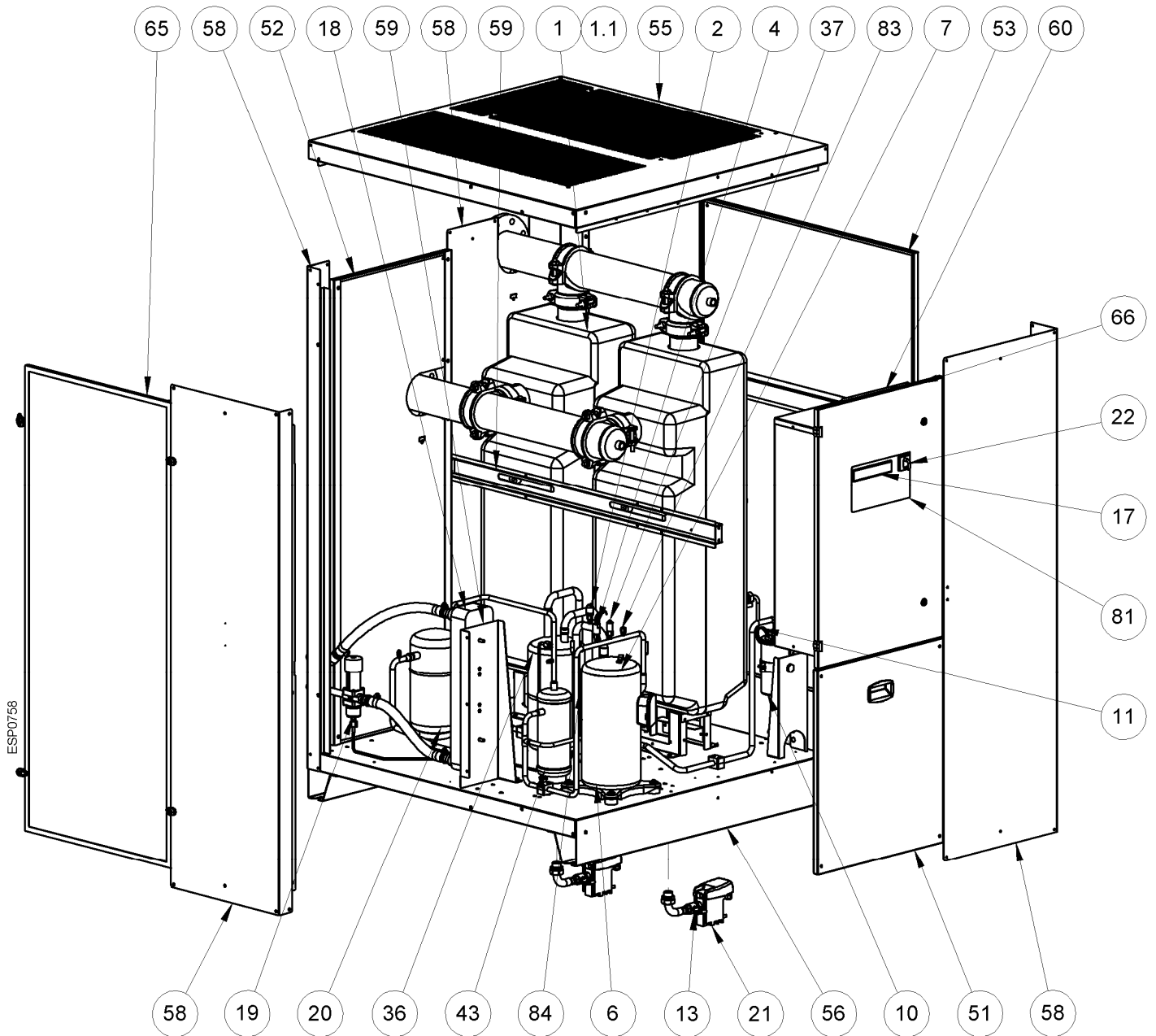





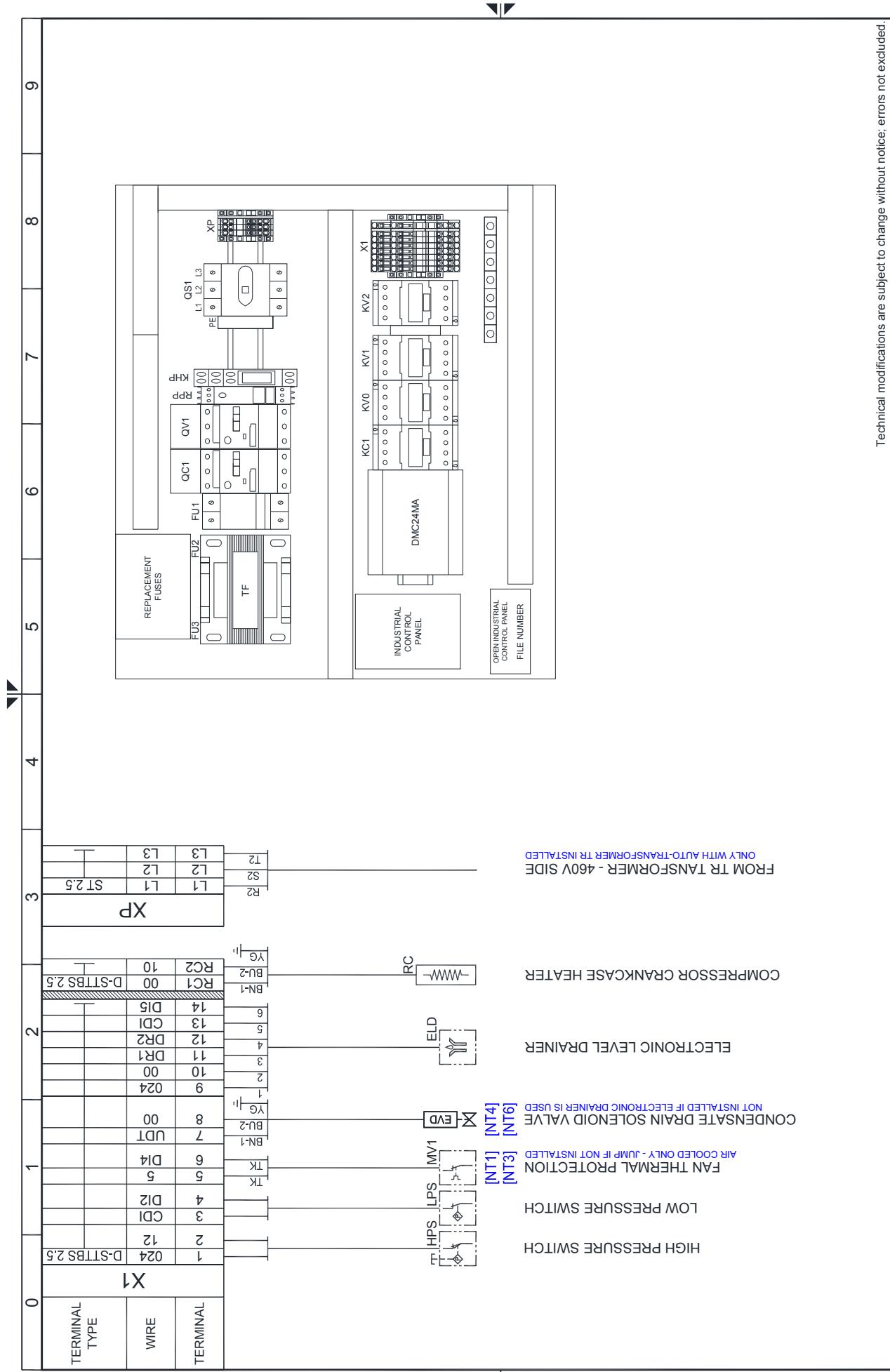

Technical modifications are subject to change without notice; errors not excluded.

Rev.

FRUCT5478QCD110 00

Note :

Sheet 03 of 03

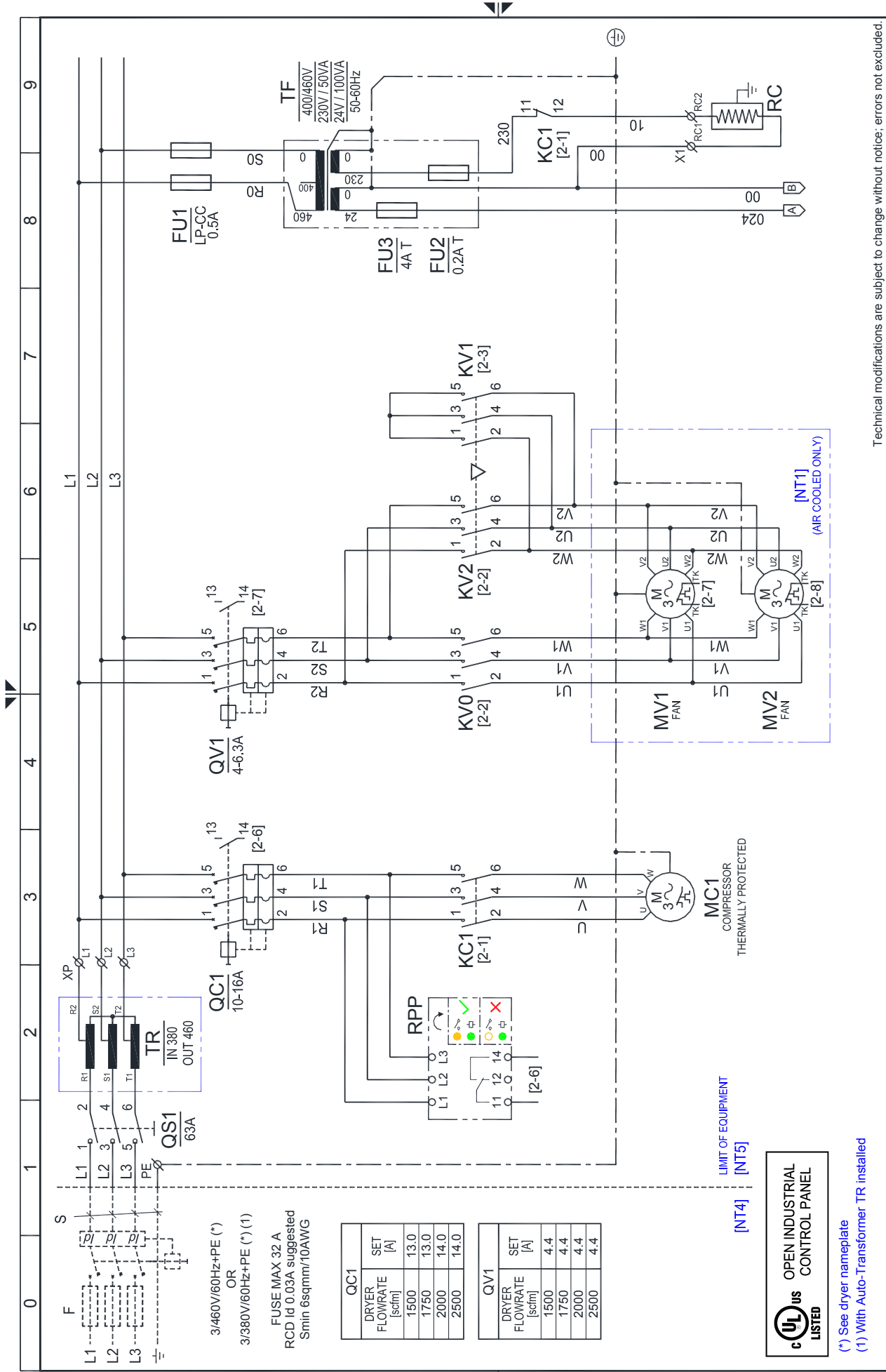

Drawing no. : **FRUCT5478QCD120**  
Rev. **00**  
Note : -  
Sheet **01** of **04**

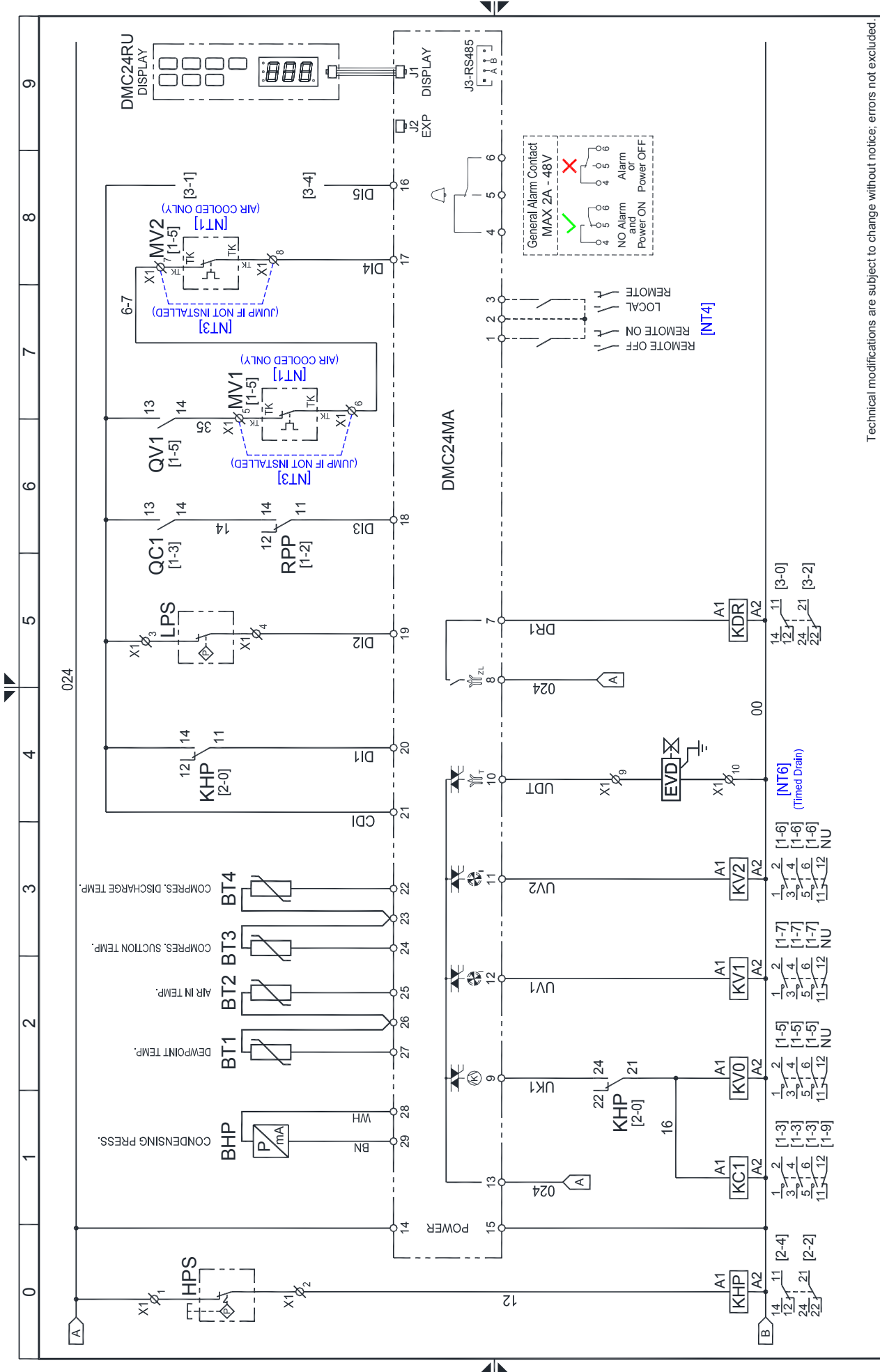

Technical modifications are subject to change without notice; errors not excluded.

Rev.

FRUCT5478QCD120

00

Note :

Sheet 02 of 04

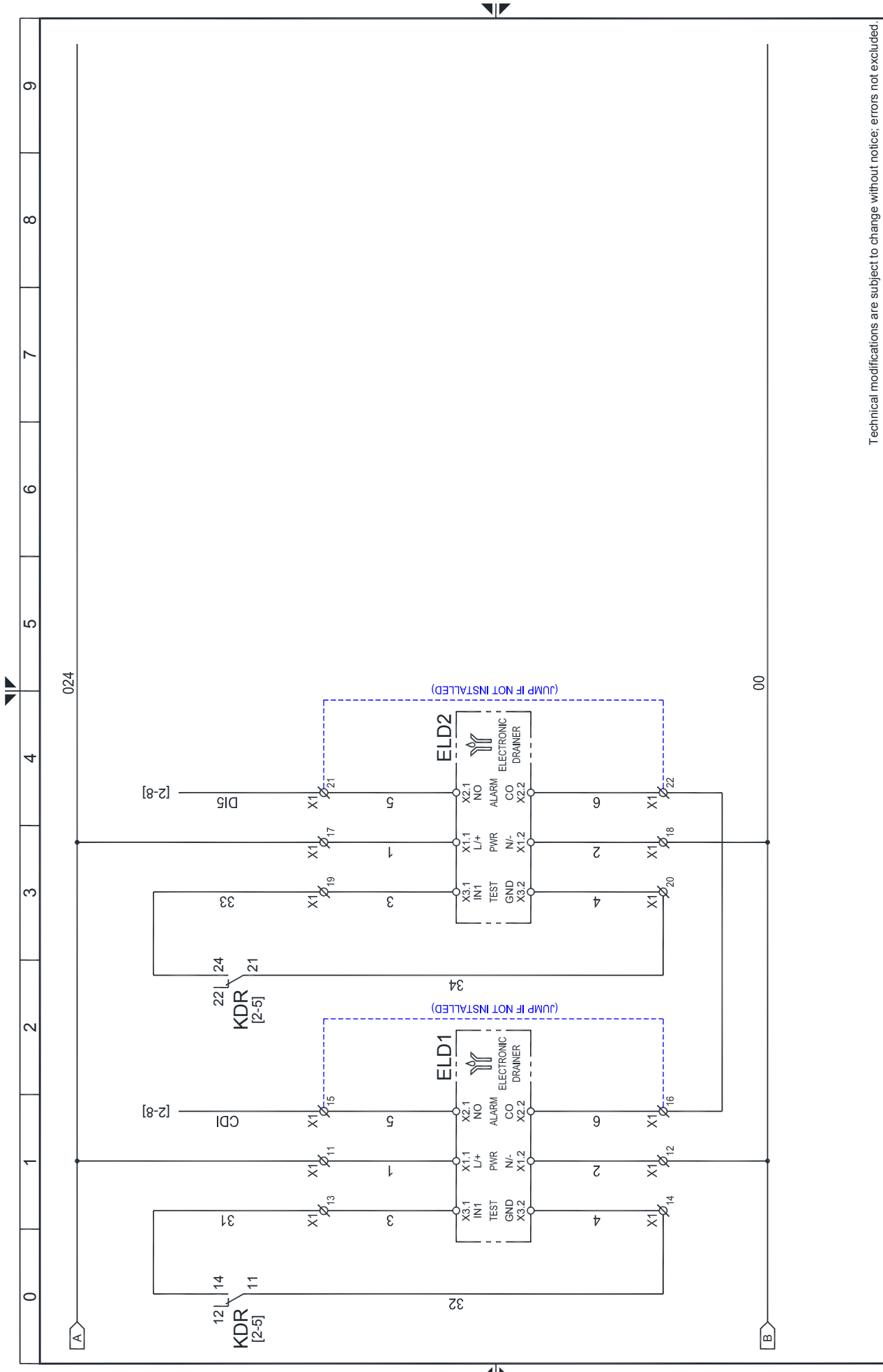

Technical modifications are subject to change without notice; errors not excluded.

Drawing no. : FRUCT5478QCD120

Rev. 00

Note : .

Sheet 03 of 04

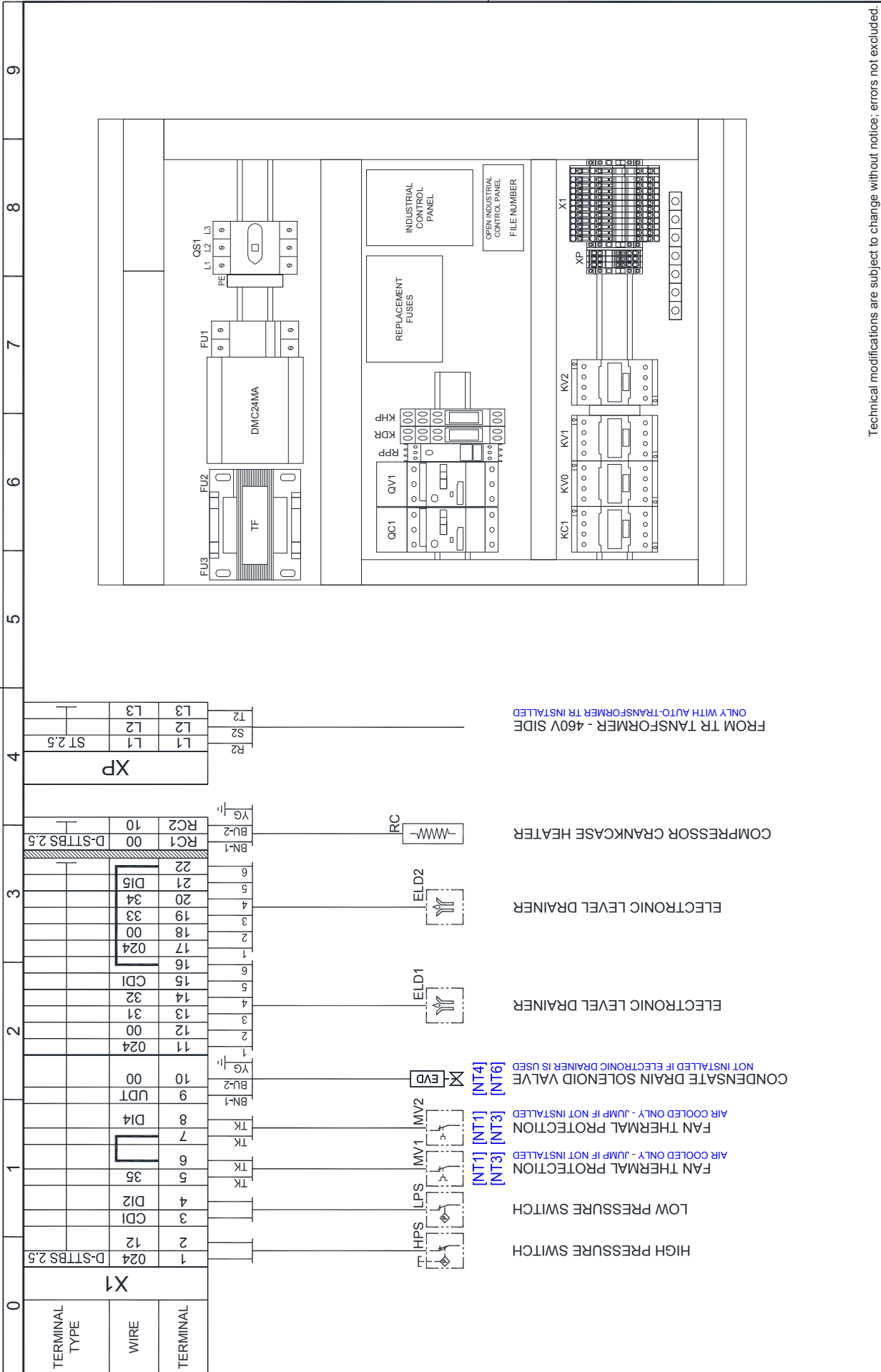

Technical modifications are subject to change without notice; errors not excluded.

Rev.

00

FRUCT5478QCD120

Note :

Sheet 04 of 04

**10 Blank pages**







## ELGi™ Brand Support

Our Uptime brand is supported, and held up, by three strong pillars:



### UPTIME Design

This speaks to the engineering and design of our products. Our R&D is dedicated to designing machines that run cooler, cleaner and longer... that are easy to service... with longer service intervals. Our commitment to an UPTIME DESIGN.



### UPTIME Components

For so many of our customers, seeing is believing. They know a quality-built machine when they see it. That's why every part on a ELGi™ compressor is a quality part. From our proprietary air ends, to our use of leak-free hoses and piping.



### UPTIME Assurance

Here is where we back our pledge, with industry-leading warranties, parts availability, loaner machines and call centers staffed by experts. All with the peace-of-mind customers have knowing their compressor is assembled locally.

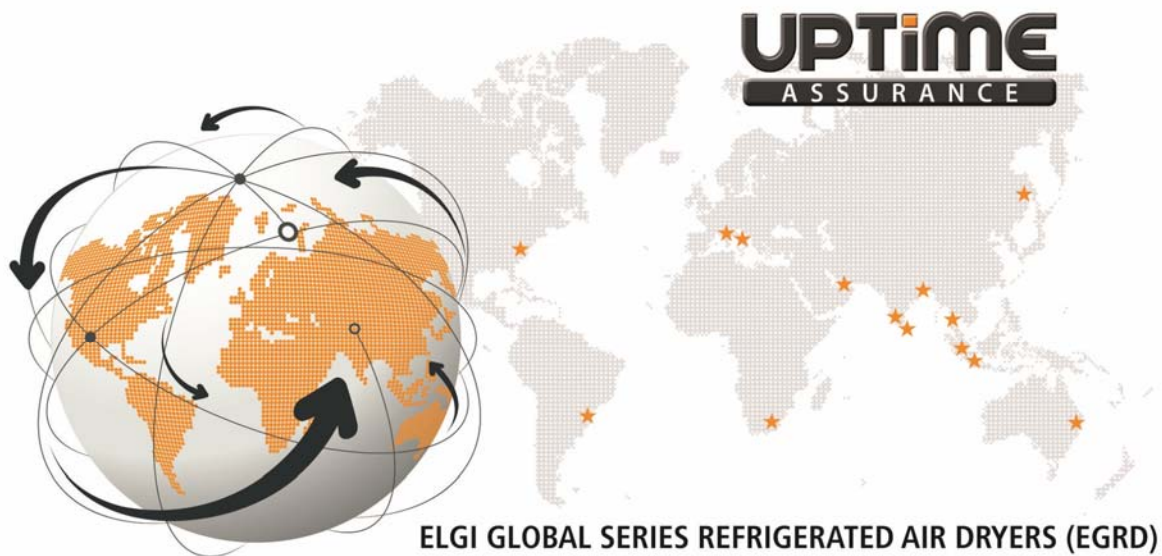

ELGI GLOBAL SERIES REFRIGERATED AIR DRYERS (EGRD)

## World-Class Products. Global Reach. Local Service.

Founded in 1960, ELGi™ Compressors has risen to become one of the world's largest manufacturers of air compressors. Our rapidly expanding global footprint now spans 63 countries, 20 offices and more than 280 distributors.



## Elgi Equipments Ltd.

Singanallur, Coimbatore-641005, India, Tel: +91-422-2589555 Fax: +91-422-2573697  
International Division: Fax: +91-422-2589401  
Email: enquiry@elgi.com Visit us at www.elgi.com

**Manufacturing locations:** China, France, India, Italy

**Subsidiaries and offices :** Australia, Bangladesh, Brazil, China, France, Indonesia, Italy, Srilanka, Thailand, UAE, USA

™ ELGi and AIRMATE are registered trade marks of Elgi Equipments Limited.

