

OPERATION AND MAINTENANCE INSTRUCTIONS
FOR

BLAST PAK

PACKAGED COMPRESSED AIR TREATMENT SYSTEM

MODELS: **FD-400** through **FD-1600**

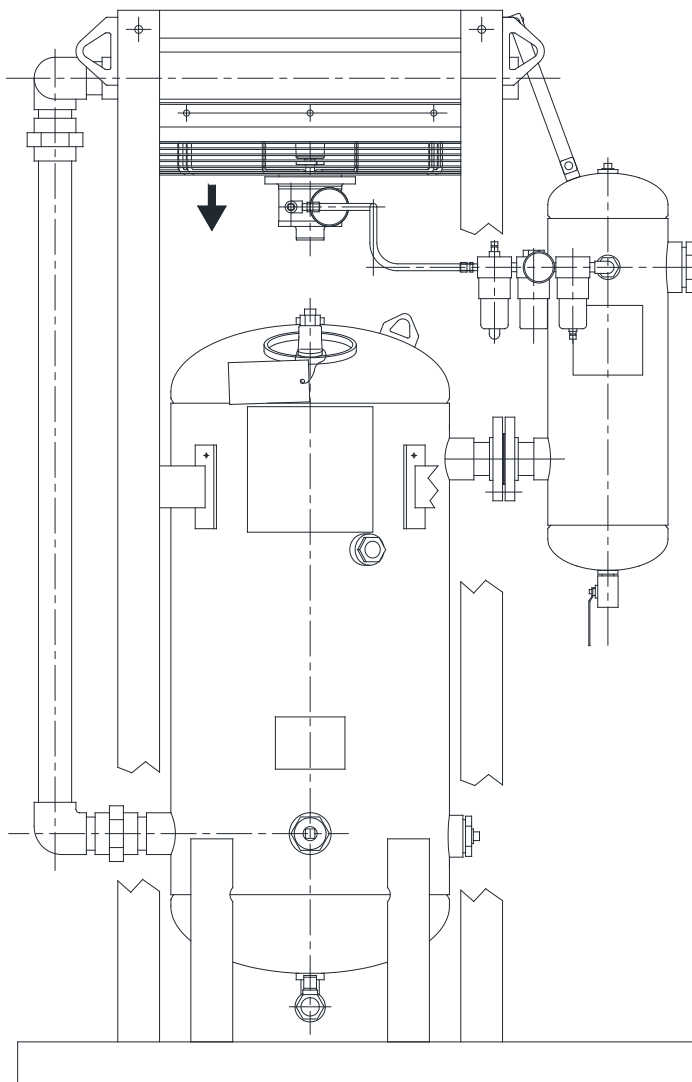

WARNING

DO NOT OPERATE THIS SYSTEM ABOVE MAXIMUM WORKING PRESSURE (MWP) AND/OR MAXIMUM OPERATING TEMPERATURE (°F) SHOWN ON THE VESSEL ASME DATA PLATE.

THIS ASME CODE VESSEL MUST BE PROTECTED BY A PRESSURE RELIEF VALVE. Refer to OSHA 1910.169 Par. b, Sub. Par (3) and ASME Boiler and Pressure Vessel Code, Section VIII, Division 1, UG-125 through UG-136. Also comply with all applicable state and local codes.

DO NOT ATTEMPT TO REMOVE OR REPAIR ANY PART OF THE SYSTEM UNTIL IT IS COMPLETELY DEPRESSURIZED. SERIOUS PERSONAL INJURY MAY RESULT IF THIS SAFETY RULE IS NOT FOLLOWED.

DO NOT WELD, GRIND, OR SAND VESSEL, THIS WILL MAKE IT UNSAFE TO OPERATE. (Note: Any alteration to the vessel will void the ASME Code Certification and the warranty.)

INSPECT VESSEL, INSIDE AND OUT, REGULARLY FOR BULGES, CORROSION, DENTS, GOUGES, LEAKS OR SIGNS OF FIRE. IF DAMAGED, REMOVE FROM SERVICE IMMEDIATELY AND NOTIFY YOUR CERTIFYING AUTHORITY.

DO NOT TRY TO TIGHTEN A LEAKING HATCH COVER. IMMEDIATELY SHUT OFF THE AIR SUPPLY AND DEPRESSURIZE THE SYSTEM.

DO NOT ATTEMPT TO REMOVE THE HATCH COVER UNTIL THE SYSTEM IS COMPLETELY DEPRESSURIZED. WHEN THE VESSEL PRESSURE IS REDUCED TO ZERO, THE HATCH COVER CAN BE REMOVED BY HAND.

INSTALL A NEW GASKET EVERY TIME THE HATCH COVER IS REMOVED, OR AT LEAST ONCE PER YEAR. INSPECT THE COVER AND SEALING SURFACE FOR DAMAGE SUCH AS CORROSION, CRACKS, OR DISTORTION. IF THERE IS ANY DAMAGE, REPLACE COVER. REPLACE THE HATCH COVER EVERY FIVE YEARS REGARDLESS OF CONDITION. USE VAN AIR AUTHORIZED PARTS ONLY.

DO NOT USE POWER TOOLS OR CHEATER BARS TO TIGHTEN THE NUT ON THE HATCH COVER. TOO MUCH FORCE CAN DISTORT THE COVER AND/OR THE GASKET. IF DAMAGED BY OVERTIGHTENING, THE COVER CAN BLOW OUT AND CAUSE SERIOUS INJURY. (Note: Tighten the nut until it is snug. When the vessel is pressurized, the pressure on the cover will complete the seal.)

THE USE OF CHEMICALS OTHER THAN VAN AIR DESICCANT WILL VOID THE WARRANTY ON THE BLAST PAK.

SECTION 1

DESCRIPTION OF OPERATION

A Blast Pak is a skid mounted system consisting of an air-cooled trim cooler, a single tower dryer with a bed of desiccant tablets and a coarse afterfilter. Wet warm air enters the trim cooler where it is cooled to a temperature approaching ambient. Water is condensed out during this cooling process. The saturated air and the liquid water proceed to the inlet of the single tower dryer. The liquid water and any solid particles present are separated by gravity and fall to the dryer sump area. The process air moves upward through the bed of desiccant tablets which attract and absorb moisture from the air before it flows through the dryer outlet. The tablets dissolve gradually as they absorb the moisture. The solution, which consists of dissolved desiccant and water, falls into the sump area at the bottom of the vessel. The dryer must be drained periodically to remove the accumulated solution. A manual ball valve is supplied for this purpose. A pneumatic drain valve is available as optional equipment for automatic draining. Likewise, the desiccant in the dryer must be periodically replenished to maintain performance. The coarse afterfilter is supplied to catch any residuals that may work their way downstream.

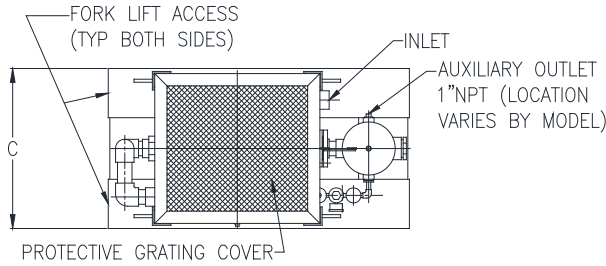

MODEL	A	B	C	D	E
FD-400	77"	49"	26"	58-9/16"	72-1/8"
FD-800	83-3/4"	54"	32-7/8"	59-1/2"	78-3/8"
FD-1200	88"	60"	32-7/8"	60"	82-5/8"
FD-1600	94-1/2"	71-1/2"	43"	59-1/8"	89-3/8"

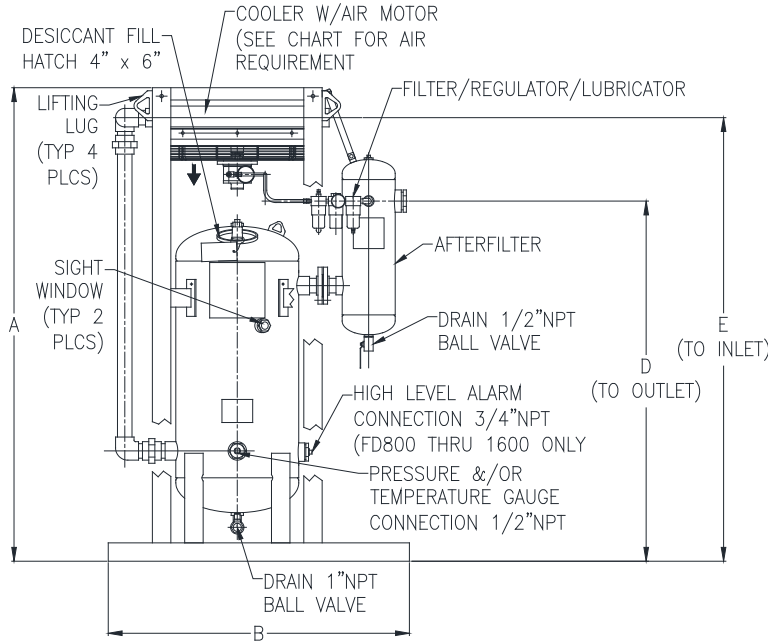

MODEL	INLET	OUTLET	WEIGHT	DRY-O-LITE DESICCANT *
FD-400	2" NPT	2" NPT	760 lbs	400 lbs
FD-800	2-1/2"NPT	2-1/2"NPT	1155 lbs	500lbs
FD-1200	2-1/2"NPT	3" NPT	1525 lbs	750 lbs
FD-1600	3" NPT	3" NPT	1875 lbs	1000 lbs

MODEL	REGULATOR SETTING FOR AIR MOTOR
FD-400	20 PSIG FOR 1725 RPM (14 SCFM)
FD-800	22 PSIG FOR 1725 RPM (21 SCFM)
FD-1200	30 PSIG FOR 1725 RPM (25 SCFM)
FD-1600	20 PSIG FOR 1725 RPM (70 SCFM)

* - ORIGINAL FILL OF DESICCANT SUPPLIED
 - CUSTOMER TO INSTALL

SECTION 3

PERFORMANCE

3.1 INLET CONDITIONS

The Blast Paks are rated as follows: 400 SCFM (FD400), 800 SCFM (FD800), 1200 SCFM (FD1200) and 1600 SCFM (FD1600) respectively at 100 PSIG, 180° F into the trim cooler (sized for 90° F ambient and 10° approach). Approach temperatures will vary with changes to the inlet conditions (flow, pressure, temperature) and the ambient temperature. The dew point out of the dryer tower is directly related to the inlet temperature entering the dryer vessel. The lower the inlet temperature, the lower the dew point of the outlet air.

The aftercooler maximum inlet temperature is 250° F. When using DRY-O-LITE desiccant, the inlet temperature to the dryer tower should not exceed 100° F.

3.2 MAXIMUM CAPACITIES FOR DRYER - SCFM (Nm³/hr)

MODEL	MAXIMUM WORKING PRESSURE	60 PSIG 4.1 Bar	80 PSIG 5.5 Bar	100 PSIG 6.9 Bar	125 PSIG 8.6 Bar	150 PSIG 10.3 Bar	175 PSIG 12.1 Bar	200 PSIG 13.8 Bar
FD-400	200 PSIG 13.8 Bar	261 419	330 531	400 643	487 783	574 923	662 1064	749 1204
FD-800	200 PSIG 13.8 Bar	521 838	661 1062	800 1286	974 1567	1149 1847	1323 2127	1497 2408
FD-1200	200 PSIG 13.8 Bar	782 1256	991 1593	1200 1929	1462 2350	1723 2770	1985 3191	2246 3611
FD-1600	175 PSIG 12.1 Bar	1042 1675	1321 2124	1600 2572	1949 3133	2297 3694	2646 4254	- -

4.1 PRESSURE RELIEF VALVE

A 2" NPT coupling is provided on the back of the dryer vessel for installing the relief valve. A pressure relief valve should be installed to conform to OSHA safety standards. Refer to OSHA Standard Section 1910.169, paragraph "b", subparagraph "3" and any other federal, state or local codes concerning pressure vessels.

See section 6 for recommended relief valves (available from your Van Air rep.)

4.2 PNEUMATIC DRAIN VALVE (P/N 39-0284)

The 1"NPT drain connection can be fitted with a PDV-500T pneumatic drain valve for automatic draining of the vessel. Ask your local Van Air representative for details.

4.3 GAUGE KITS

A 1/2" NPT coupling is provided on the lower front of the dryer for installing gauges.

See Section 6 for optional gauge kits (available from your VanAir rep.)

4.4 HIGH LEVEL ALARM (P/N 26-3667)

A 3/4"NPT connection is provided, on the FD800 through FD-1600, for installing a **HLA-120 High Level Alarm** to alert personnel that the drain solution in the dryer has reached an unacceptable level. Ask your local Van Air representative for details.

5.1 DESICCANT INSTALLATION**IMPORTANT**

The Blast Pak is shipped WITHOUT the desiccant installed. The desiccant MUST BE INSTALLED before using the system.

THE USE OF CHEMICALS OTHER THAN VAN AIR DESICCANT WILL VOID THE WARRANTY ON THE DRYER.

The procedure for filling the dryer with desiccant is outlined in Section 5.6 of this manual.

5.2 LUBRICATOR OIL

Check oil level in lubricator regularly and add oil as required. Verify that the lubricator is set as indicated in the chart below.

MODEL	LUBRICATOR SETTING
FD-400	1 DROP / MIN
FD-800	1 DROP / MIN
FD-1200	1 DROP / MIN
FD-1600	2-3 DROPS / MIN

5.3 START UP PROCEDURES

SLOWLY pressurize the air system. Allow some air to bleed through the manual drain valve. Once the system starts to pressurize, the manual drain valve can be closed. The Blast Pak is now in operation.

CAUTION

Make sure that the Blast Pak is not subjected to sudden flow surges. Always open the valves slowly to permit gradual equalization of pressure between the Blast Pak and the air supply lines.

Verify that regulator pressure is set as shown on page 1 of this manual to maintain 1725 rpm fan speed to ensure proper aftercooler performance.

5.4 OPERATION

The simple design of the single tower dryer allows for easy operation. The dryer requires two procedures to ensure peak performance.

5.4-A DAILY DRAINING

The accumulated desiccant and water solution in the bottom of the dryer should be drained frequently. If a manual drain valve is installed on the dryer, it must be opened at least once every 4 to 8 hours to drain the dryer.

The dryer may require draining on a more frequent basis on humid days. If a pneumatic drain valve is installed on the dryer, it will drain automatically as needed.

CAUTION

If the dryer is not drained regularly, it may become flooded and the accumulated liquid may enter the air system and cause damage to downstream equipment.

5.4-B REFILLING THE DRYER WITH DESICCANT

During the drying process, the desiccant tablets dissolve slowly. The desiccant consumption rate is dependent on several factors, such as inlet temperature, flow and pressure. To check the level of the desiccant bed, look into one of the sight windows. If light can be seen through the opposite sight window, the desiccant supply must be replenished to ensure dryer performance.

Reference Section 5 for refilling instructions and estimated consumption rates.

IMPORTANT

The use of other than Van Air desiccant will void the warranty on the Blast Pak.

6.1 DRAIN VESSEL DAILY

Drain the vessel by opening the drain valve and allowing the solution to discharge; then close the drain valve completely. The accumulated solution must be drained after every 4 to 8 hours of operation. An optional pneumatic drain valve can be installed to drain the vessel automatically as needed.

IMPORTANT

The drain solution may contain lubricants. Comply with all applicable regulations concerning the disposal of these chemicals.

6.2 CHECK DESICCANT LEVEL BEFORE OPERATION

Look into one of the sight windows. If light can be seen through the opposite sight window, the desiccant supply must be replenished to ensure dryer performance.

WARNING

IF THE SIGHT WINDOWS ARE DAMAGED IN ANY WAY, THEY MUST BE REPLACED IMMEDIATELY WITH VAN AIR PART NO. 26-0104 only.

Check the operation of all equipment installed before and after the Blast Pak.

Inspect the hatch cover for signs of corrosion and/or leaks. Replace the cover and/or gasket as necessary.

6.3 CHECK OIL LEVEL IN LUBRICATOR

Verify that there is sufficient amount of oil in the lubricator and add oil as needed. See section 8 for oil part number.

6.4 CHECK FILTER IN FRL

Replace filter as needed. See section 8 for filter part number.

6.5 CLEAN AFTERCOOLER CORE

The core should be cleaned regularly. Accumulation of dirt or other contaminants such as oils will greatly reduce the efficiency of the aftercooler.

Normal accumulation of dirt can be removed by blowing the core off with compressed air. If the core becomes contaminated with oil-laden particles, it can be steam cleaned. **Clean with extreme care as the aluminum fins can be easily damaged.**

6.6 ADDING DESICCANT

Shut down the air system and open the drain valve to allow the dryer to depressurize completely.

Loosen the nut on the hatch cover.

Push on the hatch cover. If the vessel is depressurized, the cover will unseal. Once the seal is broken, tilt the hatch cover and remove it from the dryer.

Add the amount of desiccant tablets required to raise the supply to the maximum operating level; then level off the tablet bed.

Amount of desiccant required to fill from sight window to maximum fill level:

MODEL	DRY-O-LITE
FD-400	150lb.
FD-800	250 lb.
FD-1200	250 lb.
FD-1600	400 lb.

CAUTION

Make sure the desiccant level is below the screen on the outlet pipe.

Do NOT overfill the vessel. Adequate space must be left to allow the hatch cover to be installed.

Inspect the hatch cover and sealing surface. If there is any damage, replace the cover. Replace the cover every 5 years regardless of condition. The gasket should be replaced every time the hatch cover is removed or at least once a year.

Check the sealing surface of the opening. If it is contaminated with dirt or rust, it must be cleaned before installing the hatch cover. A contaminated surface may prevent the gasket from properly sealing.

Install the filler hatch cover and a new gasket. Tighten the nut on the hatch cover until it is snug. Overtightening will cause damage to the nut. The cover will seal when the vessel is pressurized.

Start up the dryer following the procedures in Section 4.3.

6.7 ESTIMATING DESICCANT USAGE

The ANNUAL DESICCANT CONSUMPTION RATE table is a guide to estimate the desiccant usage for your installation.

The consumption rate is an approximation of how much desiccant will be added over a period of one year.

The figure is an average and may vary depending upon your actual conditions (i.e. 24 hour operation, higher inlet temperature, excessive liquid water content, contaminants etc.)

The desiccant bed level should be maintained to at least the sight window level at all times to ensure optimum drying capabilities.

To use the chart, first determine the SCFM that is being processed through the Blast Pak. Then locate the nearest flow rate listed on the chart and interpolate as needed.

(This chart is based on 1 shift for a one year period (2,000 hours)@ 100 psig inlet pressure and 75°F inlet temperature into dryer vessel, 100% RH.)

The consumption rate is proportional to the moisture loading. Each 20°F increase in inlet temperature changes the moisture loading by a factor of nearly 2:1.

For special applications requiring desiccants other than DRY-O-LITE, consult factory.

FLOW SCFM	DRY-O-LITE LBS/YEAR
200	264
400	528
600	792
800	1056
1000	1320
1200	1584
1400	1848
1600	2112

7.1 SHUTDOWN

Turn off air supply to Blast Pak.

Open afterfilter drain valve and depressurize the system completely.

7.2 PREPARATION FOR STORAGE

The air motor needs to be flushed to remove excessive dirt, foreign particles, moisture and/or oil that accumulates in the air motor during normal operation. Flushing helps to maintain proper motor performance and extends service life.

Perform flushing procedure when Blast Pak is to be idle for more than 5 days, or if it is to be placed in storage.

Use only Van Air Flushing Solvent (p/n 26-7157). **DO NOT use kerosene or ANY other combustible solvents to flush the air motor.**

FLUSHING PROCEDURE

1. Remove pipe plug from tee in air motor air supply piping.
2. Remove exhaust muffler from air motor.
3. Spray flushing solvent (Van Air p/n 26-7157) through tee into air motor intake port for 5 to 10 seconds.

4. Rotate motor shaft/fan, by hand, for one minute in each direction.
5. Re-install the plug in the tee and cover the exhaust port with a cloth.
6. **You must wear eye protection for this step.** Restart the motor at a low pressure (approximately 10 PSIG) and run it until there is no trace of solvent in the exhaust air.
7. Listen for changes in the sound of the motor. If the motor sounds smooth, the Blast Pak is ready for storage. If the motor does not sound like it is running smooth it will need to be serviced.
8. Disassemble the exhaust muffler that was removed in step 2. Clean the felt and reassemble the exhaust muffler.
9. Install the exhaust muffler on the air motor.
10. Set the regulator for the air motor, per the chart on page 2.

7.3 STORAGE

Store the Blast Pak in location that is free from extreme humidity and corrosive gasses, which can damage the unit.

DESCRIPTION	PART NO.	FD-400 QTY	FD-800 QTY	FD-1200 QTY	FD-1600 QTY
Gasket for 4"x6" hatch cover	18-0394	1	1	1	1
Hatch Cover, 4" x 6"	46-3003	1	1	1	1
Sight Window	26-0104	2	2	2	2
Manual Drain Valve 1" NPT	14-0451	1	1	1	1
Manual Drain Valve 1/2" NPT	14-0450	1	1	1	1
Air Motor for Aftercooler	26-6277	1	-	-	-
Air Motor for Aftercooler	34-0926	-	1	1	-
Air Motor for Aftercooler	34-0925	-	-	-	1
Filter-Regulator-Lubricator	26-7039	1	-	-	-
Filter-Regulator-Lubricator	26-7009	-	1	1	-
Filter-Regulator-Lubricator	26-7040	-	-	-	1
Element for FRL	26-7056	1	-	-	-
Element for FRL	26-7027	-	1	1	-
Element for FRL	26-7041	-	-	-	1
Oil for Lubricator (Quart)	26-7032	1	1	1	1
Flushing Solvent	26-7157	1	1	1	1
FD-400 Muffler	26-7130	1	-	-	-
FD-800 & 1200 Muffler	26-7131	-	1	1	-
FD-1600 Muffler	26-7132	-	-	-	1
DESICCANT					
DRY-O-LITE Desiccant, 50 LB BAG	33-0311	8	10	15	20
DRY-O-LITE Desiccant, 506 LB DRUM	33-0203	-	1	2	2
OPTIONAL EQUIPMENT					
Relief Valve 3/4" NPT 200# set pressure	14-1800	1	-	-	-
Relief Valve 1-1/2" NPT 200# set pressure	14-2307	-	1	1	-
Relief Valve 1-1/2" NPT 175# set pressure	14-2308	-	-	-	1
Pressure gauge kit	29-0252	1	1	1	1
Pressure gauge only	29-0151	1	1	1	1
Temperature gauge kit	29-0326	1	1	1	1
Temperature gauge only	29-0108	1	1	1	1
Thermowell only	29-0107	1	1	1	1
Combination pressure/temperature gauge	29-0200	1	1	1	1
HLA-120 High level alarm kit	26-3667	-	1	1	1
Automatic drain valve PDV-500T	39-0284	1	1	1	1
White touch up paint (9 oz. spray can)	45-0152	1	1	1	1

SAFETY PRECAUTIONS

Safety is everybody's business and is based on your use of good common sense. All situations or circumstances cannot always be predicted and covered by established rules. Therefore, use your past experience, watch out for safety hazards and be cautious.

<p>⚠ DANGER</p>	<p>⚠ DANGER</p>	<p>⚠ WARNING</p>	<p>⚠ WARNING</p>
			
<p>DISCHARGE AIR USED FOR BREATHING WILL CAUSE SEVERE INJURY OR DEATH. CONSULT FILTRATION SPECIALIST FOR ADDITIONAL FILTRATION AND TREATMENT EQUIPMENT TO MEET HEALTH AND SAFETY REGULATIONS.</p>	<p>AIR AND OIL UNDER PRESSURE WILL CAUSE SEVERE PERSONAL INJURY OR DEATH. SHUT DOWN COMPRESSOR AND RELIEVE SYSTEM OF ALL PRESSURE BEFORE REMOVING VALVES, CAPS, PLUGS, FITTINGS, BOLTS AND FILTERS.</p>	<p>ELECTRICAL SHOCK FROM IMPROPER GROUNDING CAN CAUSE INJURY OR DEATH.</p> <p>GROUND UNIT AND RELATED EQUIPMENT ACCORDING TO NATIONAL ELECTRICAL CODE AND LOCAL REGULATIONS.</p>	<p>READ THE OPERATOR'S MANUAL BEFORE STARTING OR SERVICING THIS UNIT. FAILURE TO ADHERE TO INSTRUCTIONS CAN RESULT IN SEVERE PERSONAL INJURY OR DEATH. REPLACEMENT MANUALS CAN BE PURCHASED BY CONTACTING THE MANUFACTURER.</p>