

INSTRUCTION MANUAL



Contents

1.0 INSTALLATION2
 2.0 OPERATION3
 3.0 MAINTENANCE.....4
 TROUBLESHOOTING GUIDE.....6
 SPECIFICATIONS 7-8
 ELECTRICAL SCHEMATICS9
 DIMENSIONS AND WEIGHTS 10-12
 PARTS LIST..... 13-14
 WARRANTY 16

GENERAL SAFETY INFORMATION

⚠ CAUTION

1. Pressurized devices

This equipment is a pressure containing device.

- Do not exceed maximum operating pressure as shown on equipment serial number tag.
- Make certain equipment is depressurized before servicing.

2. Electrical

This equipment requires electricity to operate.

- Install equipment in compliance with national and local electrical codes.
- Standard equipment is supplied with NEMA 1 electrical enclosures and is not intended for installation in hazardous environments.
- Disconnect power supply to equipment when performing any electrical service work.

3. Breathing air

- Air treated by this equipment may not be suitable for breathing without further purification. Refer to OSHA standard 1910.134 for the requirements for breathing quality air.

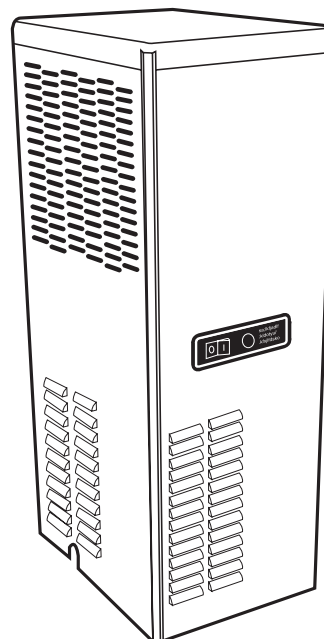

HTD SERIES

HIGH INLET

TEMPERATURE

REFRIGERATED

COMPRESSED

AIR DRYERS

1.0 INSTALLATION

1.1 Location

- A. Air compressor intake - Locate air compressor so that contaminants potentially harmful to the dryer are not drawn into the air system.
- B. Free air flow - Do not block either side of the cabinet. Observe minimum installation clearances as shown.

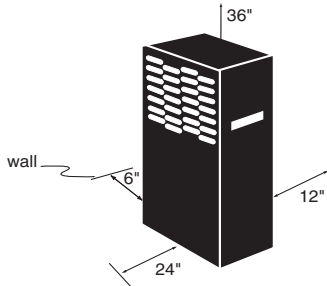

1.2 Mounting

Dryer is suitable for floor or shelf mounting.

1.3 Piping connections



- A. Air Inlet - Connect compressed air line from air compressor to air inlet using strainer supplied.

1. Install strainer (included in shipping carton) prior to dryer inlet using pipe nipple supplied or other piping as required.

NOTE: Observe flow direction arrows on strainer.

NOTE: Install strainer where it is easily accessible for cleaning.

NOTE: Use vibration dampener, if vibration exists in air line at inlet to dryer.

2. Location in the compressed air system

- A. **WARNING** Maximum working pressure - 250 psig, 17.6 kgf/cm². Do not exceed unit's Maximum Working Pressure.

- 1) For maximum capacity, install unit in air system at highest pressure possible (e.g. before pressure reducing valves)
- 2) For maximum capacity, install unit at coolest compressed air temperature possible. Maximum inlet compressed air temperature: 180°F, 82°C. If inlet air exceeds this temperature, precool the air by extending the piping between the compressor and the dryer.

- B. Air Outlet - Connect air outlet to downstream air lines.

- C. By-pass piping - If servicing the unit without interrupting the air supply is desired, piping should include inlet and outlet isolation valves and an air by-pass valve.

- D. Condensate drain - It is advisable to connect drain outlet to the condensate drainage system.

NOTE: Drain discharge is at system pressure. Drain line should be anchored to prevent whipping.

1.4 Electrical connections

- A. Dryer is designed to operate on power supply (voltage) listed on serial number tag located on the back of the dryer.

- B. Dryer is supplied with an electrical cord. Install in receptacle of proper voltage.

NOTE: Models 50 and 75 (115v only) - Install plug in receptacle rated for 20 amps. Units are supplied with 20 amp plug.



Plug

NOTE: Refrigeration system is designed to run continuously and should NOT be wired to cycle on/off with the air compressor.

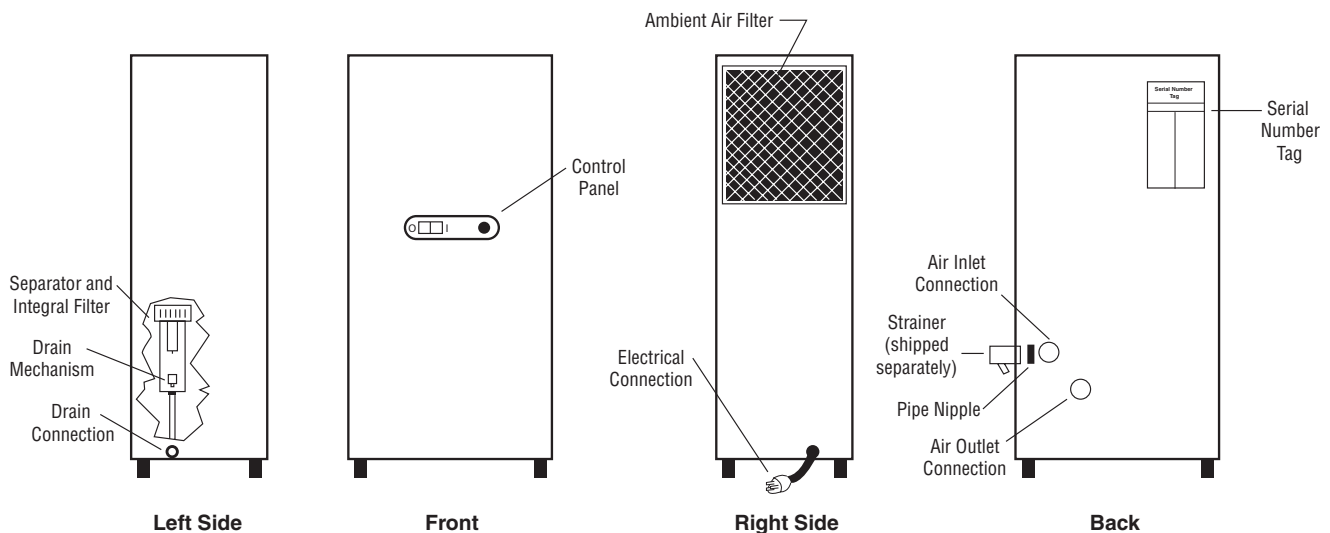

2.0 OPERATION

NOTE: Installations above 6000 feet, 1825 meters
Unit is adjusted to operate in altitudes up to 6000 feet, 1825 meters. If unit is installed in an altitude above this, and has not been preset at the factory for this altitude, contact Manufacturer's Service Department.

2.1 Start-up

Start refrigeration system by pushing the on/off switch to the ON position (depress rocker switch on side marked "I").

NOTE: The fault light may illuminate when unit is energized. Light should go out approximately 5 minutes after start-up. If light remains lit after 30 minutes or illuminates after going out, refer to Troubleshooting Guide.

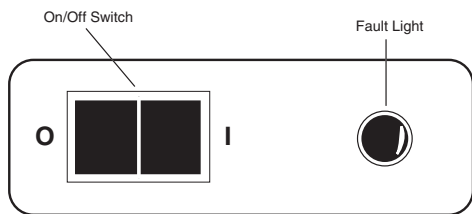

Control Panel

2.2 Operating check points

Check the following on a periodic basis:

- Rocker switch is in the ON position.
- Amber fault light is out.
- Condensate is being regularly discharged.

2.3 Minimum/maximum operating conditions

- Minimum/Maximum air pressure: 20/250 psig, 1.4/17.6 kgf/cm²
- Maximum inlet air temperature: 180°F, 82°C
- Minimum/Maximum ambient temperature: 35/110°F, 2/43°C

D. Maximum flow capacity

- For dryers without an aftercooler installed upstream
Flow capacity in scfm (m³/min) @ 180°F, 82°C inlet temperature, 160°F, 71°C inlet pressure dew point, 95°F, 35°C ambient temperature, 50°F, 10°C outlet pressure dew point, and less than 5 psi, 0.35 kgf/cm² pressure drop.

60 HZ

Inlet Pressure psig (kgf/cm ²)	175 (12.3)	150 (10.6)	125 (8.8)	100 (7.0)	
Model	20	23 (0.65)	22 (0.62)	20 (0.57)	18 (0.51)
	25	29 (0.82)	27 (0.76)	25 (0.71)	23 (0.65)
	35	41 (1.16)	38 (1.08)	35 (0.99)	32 (0.91)
	50	58 (1.64)	54 (1.53)	50 (1.42)	45 (1.27)
	75	87 (2.46)	81 (2.29)	75 (2.12)	68 (1.93)
	100	116 (3.29)	108 (3.06)	100 (2.83)	91 (2.58)
	125	145 (4.12)	135 (3.82)	125 (3.54)	114 (3.23)

50 HZ

Inlet Pressure psig (kgf/cm ²)	175 (12.3)	150 (10.6)	125 (8.8)	100 (7.0)	
Model	20	20 (0.57)	18 (0.51)	17 (0.48)	15 (0.42)
	25	24 (0.68)	23 (0.65)	21 (0.59)	19 (0.54)
	35	31 (0.88)	29 (0.82)	27 (0.76)	24 (0.68)
	50	58 (1.64)	54 (1.53)	50 (1.42)	45 (1.27)
	75	71 (2.01)	66 (1.87)	61 (1.73)	55 (1.56)
	100	97 (2.75)	90 (2.55)	83 (2.35)	76 (2.15)
	125	121 (3.43)	112 (3.17)	104 (2.95)	95 (2.69)

- For dryers with an aftercooler installed upstream
Flow capacity in scfm (m³/min) @ 100°F, 38°C inlet temperature, 100°F, 38°C inlet pressure dew point, 100°F, 38°C ambient temperature, 50°F, 10°C outlet pressure dew point, and less than 10 psi, 0.7 kgf/cm² pressure drop.

60 HZ

Inlet Pressure psig (kgf/cm ²)	175 (12.3)	150 (10.6)	125 (8.8)	100 (7.0)	
Model	20	32 (0.91)	30 (0.85)	28 (0.79)	25 (0.71)
	25	40 (1.13)	37 (1.05)	34 (0.96)	31 (0.88)
	35	55 (1.56)	51 (1.44)	47 (1.33)	43 (1.22)
	50	78 (2.21)	73 (2.07)	67 (1.90)	61 (1.73)
	75	118 (3.34)	110 (3.12)	102 (2.89)	68 (1.93)
	100	157 (4.45)	146 (4.14)	136 (3.85)	123 (3.48)
	125	197 (5.58)	183 (5.18)	170 (4.82)	155 (4.39)

50 HZ

Inlet Pressure psig (kgf/cm ²)	175 (12.3)	150 (10.6)	125 (8.8)	100 (7.0)	
Model	20	27 (0.76)	25 (0.71)	23 (0.65)	21 (0.59)
	25	33 (0.93)	31 (0.88)	29 (0.82)	26 (0.74)
	35	43 (1.22)	40 (1.13)	37 (1.05)	33 (0.93)
	50	78 (2.21)	73 (2.07)	67 (1.90)	61 (1.73)
	75	96 (2.72)	90 (2.55)	83 (2.35)	75 (2.12)
	100	131 (3.71)	122 (3.46)	113 (3.20)	102 (2.89)
	125	164 (4.65)	152 (4.31)	142 (4.02)	129 (3.65)

3.0 MAINTENANCE

CAUTION DRYER IS A PRESSURE CONTAINING DEVICE. DEPRESSURIZE BEFORE SERVICING.

3.1 Ambient air filter - Clean accumulated dust and dirt from ambient air filter monthly or more often if air flow across the condenser is impeded.

- A. Remove top panel.
- B. Remove ambient air filter by sliding upwards.

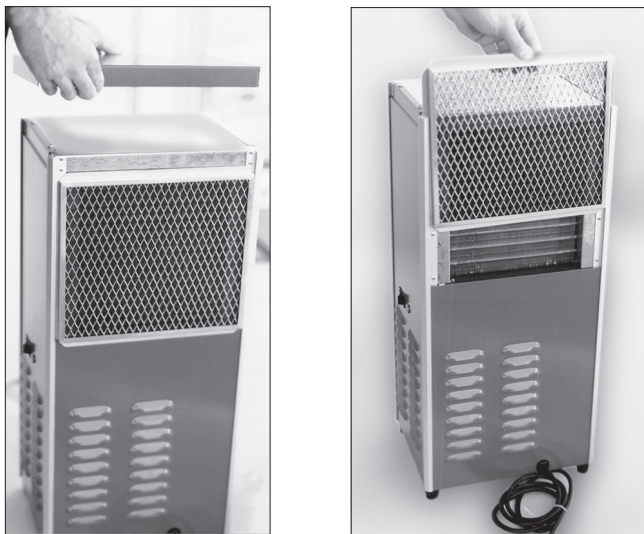

C. Wash with soap and water and allow to dry before re-installing.

NOTE: Do not use solvents to clean ambient air filter.

D. Reinstall filter and top panel.

3.2 Inlet strainer - clean inlet strainer monthly or more often if rapid clogging occurs.

- A. Shut-off compressed air supply to the strainer and depressurize.
- B. Remove screen and clean or replace.
- C. Reinstall.

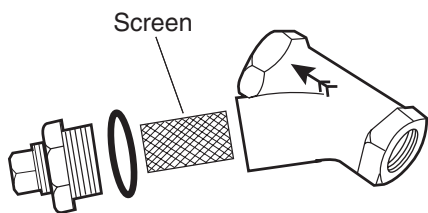

3.3 Replace separator/filter element yearly or more often if pressure drop across the dryer is excessive.

- A. Shut-off compressed air supply to the dryer and depressurize.
- B. Remove top panel.
- C. Remove two screws holding side panel and remove side panel by sliding upwards.
- D. Disconnect drain tube from bulkhead fitting in cabinet base. To remove, press the plastic collar in, toward the fitting, while pulling the tube out of the fitting.
- E. Remove bowl - push bowl up, turn bowl 1/8th turn to your left, and pull straight down.
- F. Clean filter bowl.
- G. Replace element.

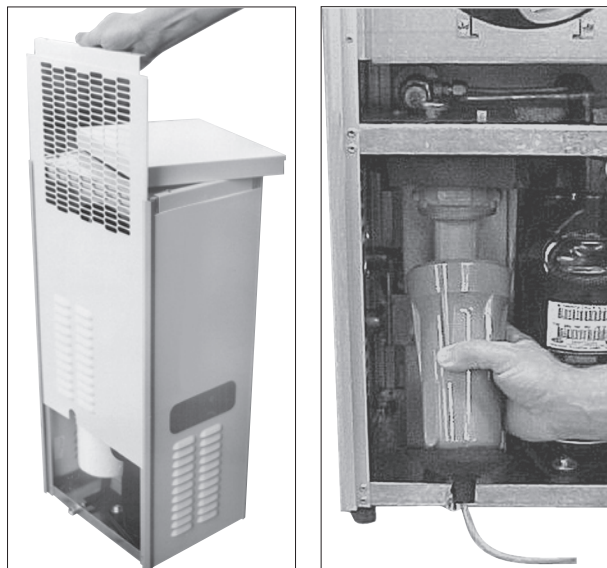

- 1. Replacing complete element
 - a) Pull off old element and discard.
 - b) Make certain O-ring inside top of replacement element is in place and push element onto filter head.
- 2. Replacing sleeve only
 - a) Pull element straight down to remove.
 - b) Remove bolt and bottom cap and remove disposable filter sleeve.
 - c) Clean separator core with soap and water if necessary
 - d) Slide new filter sleeve over separator core and replace bottom cap and hand tighten bolt.
 - e) Make certain O-ring inside top of element is in place and push element onto filter head.

- H. After making sure that O-ring and wave spring inside top of bowl are in place, reassemble bowl to head.

NOTE: Make certain O-ring is generously lubricated

NOTE: Wave spring ends should be pointed down to prevent the wave spring from interfering with reassembly.

- I. Reconnect drain tube to bulkhead fitting by pushing tube into fitting until it locks in position.
- J. Reinstall side and top panels.
- K. Repressurize dryer and resume operation.

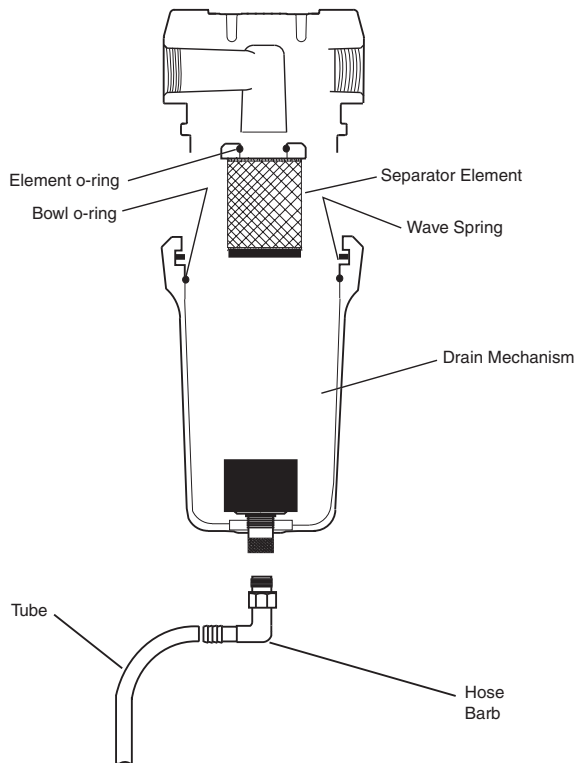

3.4 Automatic condensate drain

- Check daily to be sure automatic drain is discharging.
 - Replace drain mechanism yearly.
- A. Shut-off compressed air supply to the dryer and depressurize.
- B. Remove top panel.
- C. Remove two screws holding side panel then remove side panel by sliding upwards.
- D. Disconnect drain tube from bulkhead fitting in cabinet base. To remove, press the plastic collar in, toward the fitting, while pulling the tube out of the fitting.
- E. Remove bowl - push bowl up, turn 1/8th turn to your left, and pull bowl straight down.
- F. Remove drain tube fitting from bottom of bowl.
- G. Remove old drain mechanism by turning knurled fitting to the right (clockwise) and remove.
- H. Install new drain mechanism. If necessary, use a wire or pencil to guide the new mechanism into place.
- I. Reassemble drain tube fitting to bowl.
- J. After making sure that large O-ring in filter head is in place, reassemble bowl to head.
- K. Reconnect drain tube to bulkhead fitting by pushing tube into fitting until it locks in position.
- L. Reinstall top and side panels.
- M. Repressurize dryer and resume operation.

TROUBLESHOOTING GUIDE

SYMPTOM	POSSIBLE CAUSE(S)	CORRECTIVE ACTION
A) Water downstream of dryer	<ol style="list-style-type: none"> 1. Residual free moisture remaining in downstream pipelines 2. Air by-pass system is open 3. Inlet and Outlet connections are reversed 4. Temperatures surrounding air lines downstream of dryer have dropped below dryers dew point rating. 5. Excessive free moisture (bulk liquid) at dryer inlet 6. Condensate not being automatically drained Drain mechanism is clogged or inoperative. Drain line is restricted or frozen. 7. Dryer overloaded resulting in elevated dew point. 8. Refrigeration system not functioning properly resulting in elevated dew point. 	<p>Blow out system with dry air</p> <p>Check valve positions Check for correct connection</p> <p>Insulate or heat trace air lines exposed to low ambients or dry air to lower dew point</p> <p>Install separator ahead of dryer</p> <p>Replace drain mechanism if inoperative Open drain line Check inlet air temperature and pressure, flow rate (compressor capacity) and ambient air temperature See D below</p>
B) High pressure drop across dryer	<ol style="list-style-type: none"> 1. Inlet air strainer clogged 2. Excessive air flow 3. Separator filter clogged. 4. Freezing of moisture in evaporator because of refrigeration system improperly functioning. 	<p>Clean inlet air strainer Check flow rate Replace filter sleeve See D below</p>
C) Fault Alarm	<ol style="list-style-type: none"> 1. Dryer overloaded resulting in high air outlet temperature. 2. Refrigeration system not functioning properly resulting in high air outlet temperature. 3. Unit functioning normally but thermostatic switch is malfunctioning or not securely mounted. 	<p>See A 7</p> <p>See D below</p> <p>Contact qualified refrigeration repairman or manufacturer's service department</p>
D) Refrigeration system not functioning properly <ol style="list-style-type: none"> 1. When dryer on/off switch in on or "I" position 2. Refrigerant compressor cycles on and off 	<ol style="list-style-type: none"> a. Power failure b. Line disconnect switch open c. Blown fuses, open breaker d. Faulty wiring, loose terminals <ol style="list-style-type: none"> a. High or low ambient conditions b. Ambient air filter clogged c. Condenser fins clogged d. Fan motor or fan control switch malfunction e. Refrigerant leak <ol style="list-style-type: none"> f. Low voltage 	<p>Check power to unit Close disconnect switch Check for continuity Have electrician check electrical connections</p> <p>Check minimum/maximum temperature ranges Clean ambient air filter Clean condenser Replace fan motor or fan control switch Contact qualified refrigeration repairman or manufacturer's service department Check wiring</p>

SPECIFICATIONS - Models 20 thru 75

Description	Model						
	20	25	35	50	75		
Operating Conditions							
Rated Capacity	scfm	60 / 50 Hz	20 / 17	25 / 21	35 / 27	50 / 50	75 / 61
@125 psig, 8.8 kgf/cm ² *	m ³ /min	60 / 50 Hz	0.57 / 0.48	0.71 / 0.59	0.99 / 0.76	1.42 / 1.42	2.12 / 1.7
Maximum Working Pressure	250 psig (17.6 kgf/cm ²)						
Maximum Inlet Temperature	180°F (82°C)						
Min/Max. Ambient Temperature	35-110°F (2-43°C)						
Pressure Drop @	psi	60 / 50 Hz	4.5 / 2.9	3.3 / 2.4	4.7 / 2.9	4.5 / 4.5	3.8 / 2.2
rated capacity	(kgf/cm ²)	60 / 50 Hz	(0.32 / 0.20)	(0.23 / 0.17)	(0.33 / 0.20)	(0.32 / 0.32)	(0.27 / 0.15)
Refrigeration System Data							
Compressor Type	Hermetic, Rotary, Permanent Split Capacitor						
BTU/HR - Refrigeration Only							
@ ASRE-T Conditions	60 / 50 Hz	8720 / 7043			12500 / 9970		
Outlet Air Temperature (nominal @ rated conditions)	155°F (68°C)						
Refrigerant Type	R-407C						
Refrigerant Charge	oz (grams)	60 / 50 Hz	See Dryer Serial Tag				
Suction Pressure Setting	67 psig (4.7 kgf/cm ²)						
Factory Test (design) Pressure high side/low side	330/178 psig (23.2/12.5 kgf/cm ²)						
Condenser Fan Switch Setting (in-out)	240-180 psig (16.9-12.7 kgf/cm ²)						
Air Flow Across Condenser	cfm	60 / 50 Hz	280 / 235			620 / 515	
	m ³ /min	60 / 50 Hz	(7.9 / 6.7)			(17.6 / 14.6)	
Electrical Data							
Unit	115/1/60						
VAC/phase/Hz			115/1/60				
Minimum/maximum volts	98-127						
Full Load Amps (FLA)			8.7			12.6	
Branch Circuit Fuse Size (amps)			15			20	
Compressor							
Volts/phase/Hz	115/1/60						
Rated Load amps (RLA)			7.5			11.0	
Locked Rotor amps (LRA)			44.0			67.0	
Watts (input)			853			1220	
Overload	Thermal and Current (Auto Reset)						
Condenser fan motor							
Volts/phase/Watts (output)			115/1/25			115/1/35	
Full Load Amps (FLA)			1.2			1.6	
Other Loads							
Volts/amps/Watts	115/0.002/0.2						
Unit	220-240/1/50						
VAC/phase/Hz			220-240/1/50				
Minimum/maximum volts	198-264						
Full Load Amps (FLA)			3.4			6.0	
Branch Circuit Fuse Size (amps)			15				
Compressor							
Volts/phase/Hz	220-240/1/50						
Rated Load amps (RLA)			2.8			5.1	
Locked Rotor amps (LRA)			18.6			28.0	
Watts (input)			690			990	
Overload	Thermal and Current (Auto Reset)						
Condenser fan motor							
Volts/phase/Watts (output)			220-240/1/18.3			220-240/1/25.6	
Full Load Amps (FLA)			0.6			0.8	
Other Loads							
Volts/amps/Watts	220-240/0.002/0.4						

* Capacity @ 180°F, 82°C inlet temperature, 160°F, 71°C inlet pressure dew point, 95°F, 35°C ambient temperature, 50°F, 10°C outlet pressure dew point, and less than 5 psi, 0.35 kgf/cm² pressure drop.

SPECIFICATIONS - Models 100 and 125

Description			Model	
			100	125
Operating Conditions				
Rated Capacity	scfm	60 / 50 Hz	100 / 83	125 / 104
@125 psig, 8.8 kgf/cm ² *	m ³ /min	60 / 50 Hz	2.83 / 2.35	3.54 / 2.95
Maximum Working Pressure			250 psig (17.6 kgf/cm ²)	
Maximum Inlet Temperature			180°F (82°C)	
Min/Max. Ambient Temperature			35-110°F (2-43°C)	
Pressure Drop @	psi	60 / 50 Hz	3.5 / 2.6	4.6 / 3.1
rated capacity	(kgf/cm ²)	60 / 50 Hz	(0.25 / 0.18)	(0.32 / 0.22)
Refrigeration System Data				
Compressor Type			Hermetic, Rotary, Permanent Split Capacitor	
BTU/HR - Refrigeration Only @ ASRE-T Conditions			24880 / 19543	
Outlet Air Temperature (nominal @ rated conditions)			155°F (68°C)	
Refrigerant Type			R-22	
Refrigerant Charge	oz (grams)	60 / 50 Hz	See Dryer Serial Tag	
Suction Pressure Setting			67 psig (4.7 kgf/cm ²)	
Factory Test (design) Pressure high side/low side			278/144 psig (19.6/10.1 kgf/cm ²)	
Condenser Fan Switch Setting (in-out)			240-180 psig (16.9-12.7 kgf/cm ²)	
Air Flow Across Condenser	cfm	60 / 50 Hz	830 / 690	
	m ³ /min	60 / 50 Hz	(23.5 / 19.5)	
Electrical Data				
Unit			208-230/1/60	
VAC/phase/Hz			230/1/60	
Minimum/maximum volts			187-253	
Full Load Amps (FLA)			11.7	
Branch Circuit Fuse Size (amps)			20	
Compressor			208-230/1/60	
Volts/phase/Hz			208-230/1/60	
Rated Load amps (RLA)			10.6	
Locked Rotor amps (LRA)			58.0	
Watts (input)			2415	
Overload			Thermal and Current (Auto Reset)	
Condenser fan motor			230/1/60	
Volts/phase/Watts (output)			230/1/60	
Full Load Amps (FLA)			1.1	
Other Loads			230/0.002/0.4	
Volts/amps/Watts			230/0.002/0.4	
Unit			220-240/1/50	
VAC/phase/Hz			220-240/1/50	
Minimum/maximum volts			198-264	
Full Load Amps (FLA)			10.5	
Branch Circuit Fuse Size (amps)			15	
Compressor			220-240/1/50	
Volts/phase/Hz			220-240/1/50	
Rated Load amps (RLA)			9.4	
Locked Rotor amps (LRA)			38.7	
Watts (input)			2050	
Overload			Thermal and Current (Auto Reset)	
Condenser fan motor			230/1/50	
Volts/phase/Watts (output)			230/1/50	
Full Load Amps (FLA)			1.1	
Other Loads			220-240/0.002/0.4	
Volts/amps/Watts			220-240/0.002/0.4	

* Capacity @ 180°F, 82°C inlet temperature, 160°F, 71°C inlet pressure dew point, 95°F, 35°C ambient temperature, 50°F, 10°C outlet pressure dew point, and less than 5 psi, 0.35 kgf/cm² pressure drop.

ELECTRICAL SCHEMATICS

Models 20 thru 75 - All Voltages
Only Models 50 and 75 - 230-1-50/60

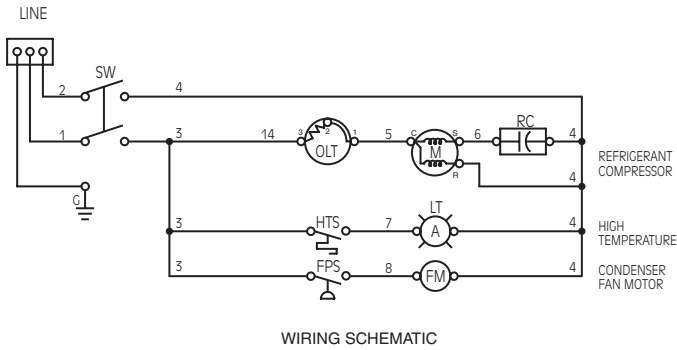

Only Models 50 and 75 - 115-1-50/60

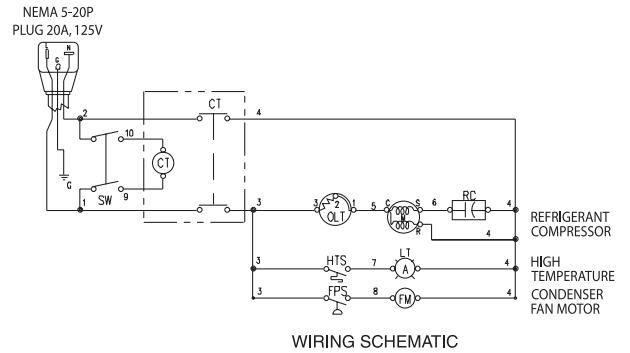

Models 100 and 125 - All Voltages

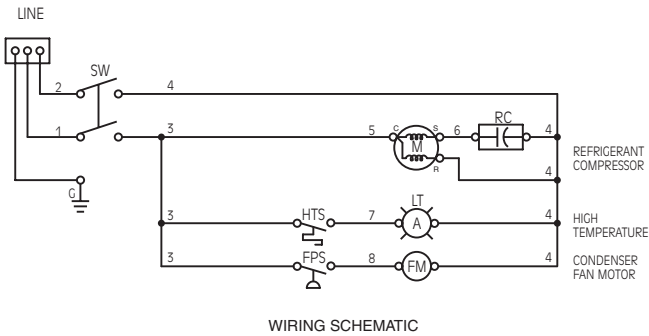

LEGEND

- SW - On/Off Switch
- OLT - Thermal Overload
- M - Compressor Motor
- RC - Run Capacitor
- HTS - High Temperature Switch
- LT - Fault Light
- FPS - Fan Pressure Switch
- FM - Fan Motor
- TB - Terminal Block
- CT - Contactor w/115V Coil

Models 20 thru 125 - All Voltages

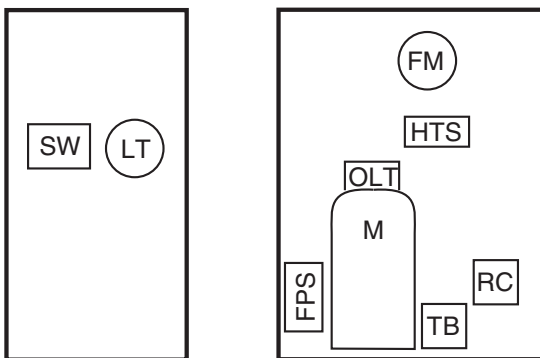

Front of Dryer
(Outside)

Right Side of Dryer
(Inside)

COMPONENT LOCATIONS

Only Models 50 and 75 - 115-1-50/60

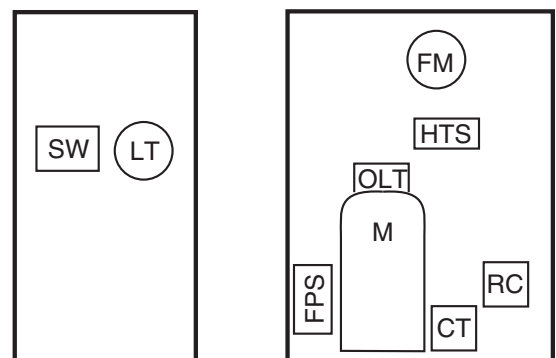

Front of Dryer
(Outside)

Right Side of Dryer
(Inside)

COMPONENT LOCATIONS

DIMENSIONS AND WEIGHTS

Models 20, 25, 35

Model	Weight
20	79 lbs (36 kg)
25	80 lbs (36 kg)
35	81 lbs (37 kg)

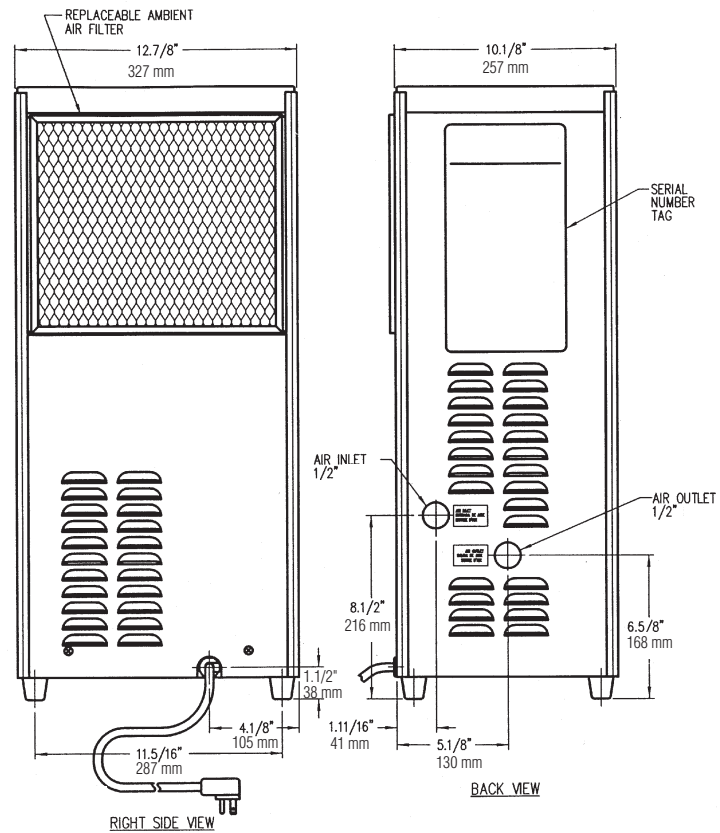
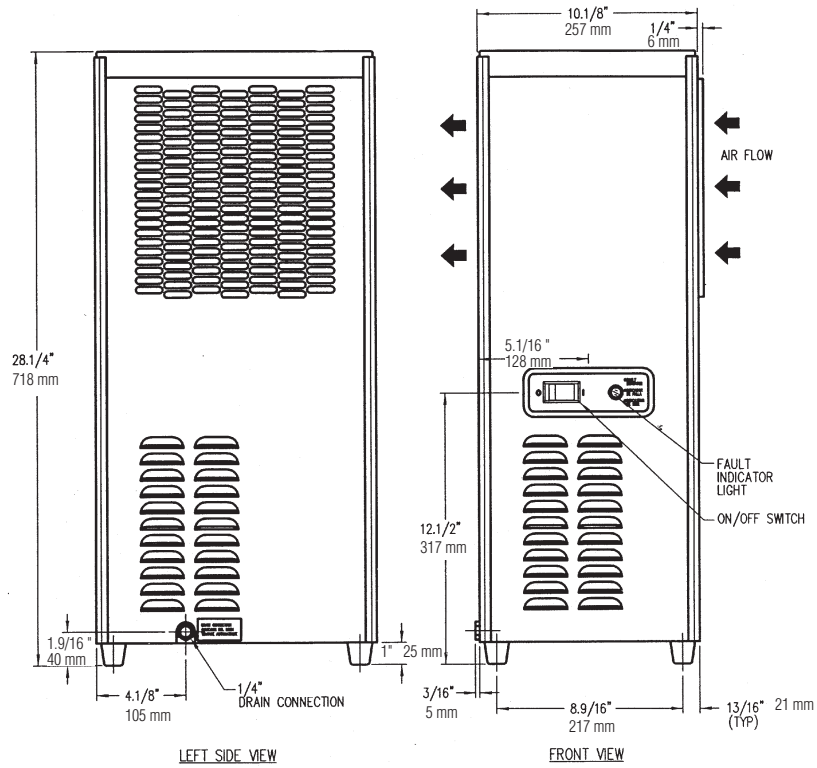

DIMENSIONS AND WEIGHTS

Models 50 and 75

Model	Weight
50	150 lbs (68 kg)
75	155 lbs (70 kg)

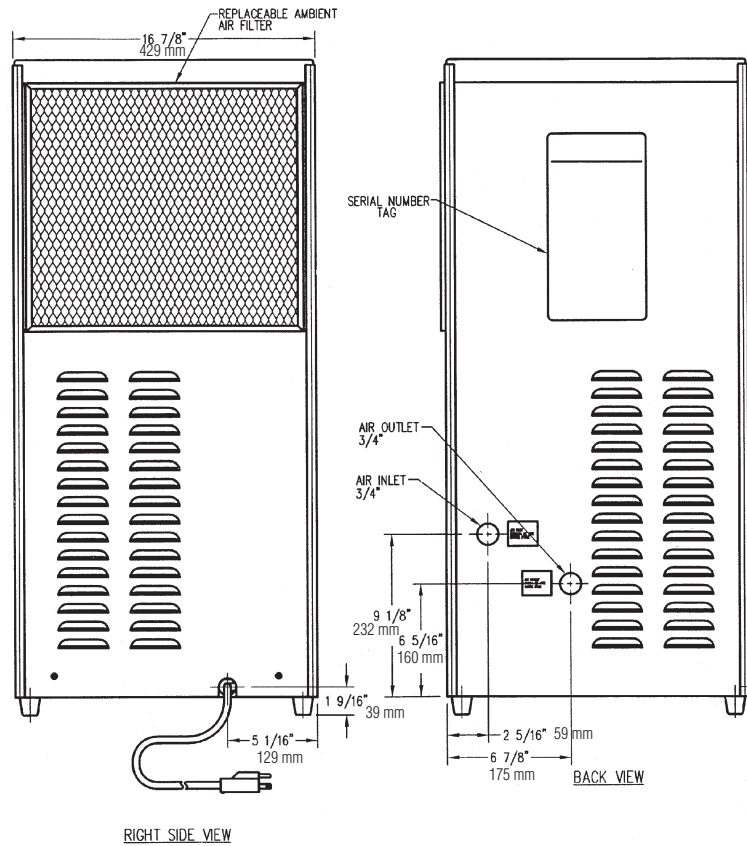
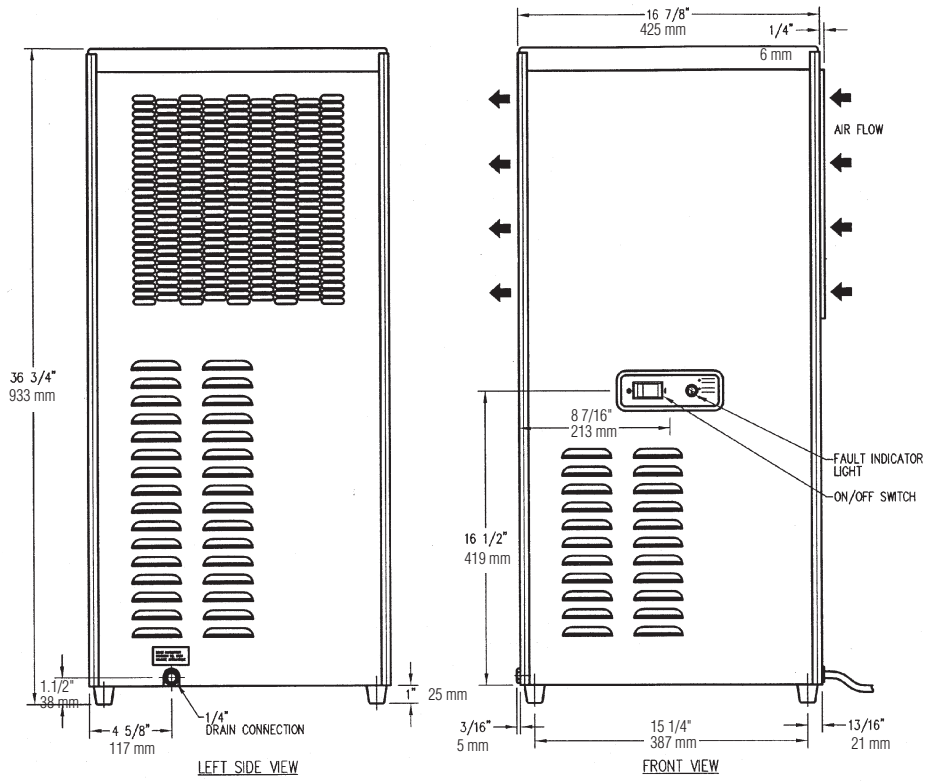

DIMENSIONS AND WEIGHTS

Models 100 and 125

Model	Weight
100	187 lbs (85 kg)
125	189 lbs (86 kg)

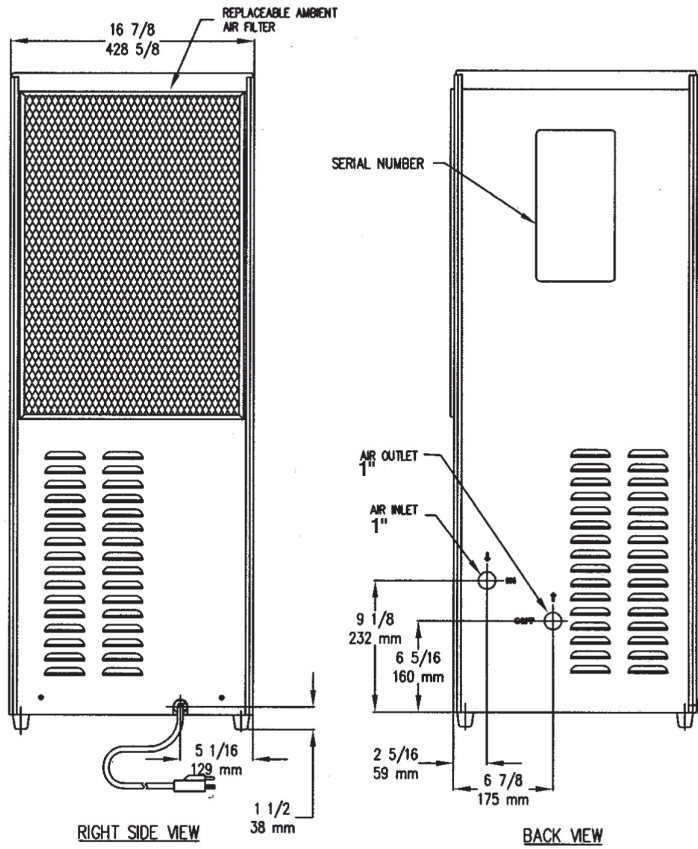
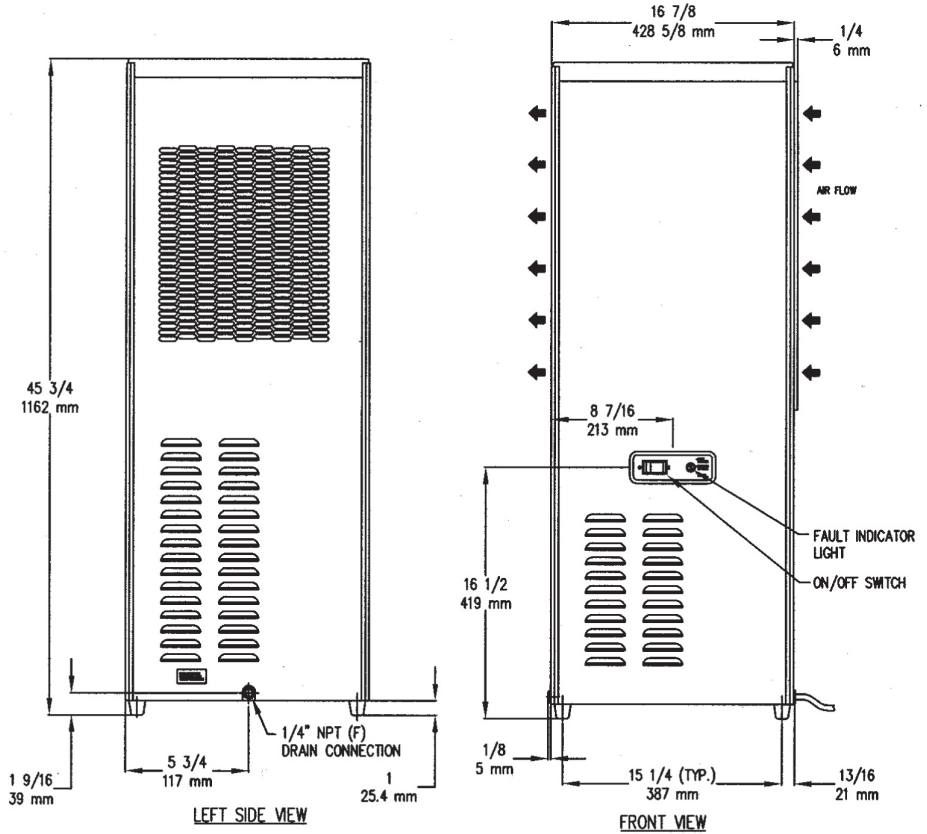

PARTS LIST

PARTS DESCRIPTION	20	25	35	50	75
Separator					
*Separator/Filter Cartridge	E9-16	E9-16	E9-16	E9-20	E9-24
Filter Sleeve	S9-16	S9-16	S9-16	S9-20	S9-24
*Drain Mechanism	05.4170-08	05.4170-08	05.4170-08	05.4170-08	05.4170-08
Bowl	03.0810-04	03.0810-04	03.0810-04	03.0810-05	03.0810-06
*O-ring Bowl	9320.552.14	9320.552.14	9320.552.14	9320.552.16	9320.552.16
Inlet (Compressed Air) Strainer					
Strainer, inlet	4731.735.1	4731.735.1	4731.735.1	4731.735.2	4731.735.2
*Screen, strainer	4731.735.5	4731.735.5	4731.735.5	4731.735.7	4731.735.7
Electrical					
Switch on/off	6110.706.7	6110.706.7	6110.706.7	6110.706.7	6110.706.7
Light, Fault (amber) 115/1/60	6350.451.10	6350.451.10	6350.451.10	6350.451.10	6350.451.10
Light, Fault (amber) 220-240/1/50	6350.451.11	6350.451.11	6350.451.11	6350.451.11	6350.451.11
Cord Set 115/1/60	03.7133-10	03.7133-10	03.7133-10	03.7133-11	03.7133-11
Cord Set 230/1/60	03.7133-24	03.7133-24	03.7133-24	03.7133-25	03.7133-25
Cord Set 220-240/1/50	03.7133-12	03.7133-12	03.7133-12	03.7133-12	03.7133-12
Capacitor, run 115/1/60	5910.103.17	5910.103.17	5910.103.17	5910.103.49	5910.103.49
Capacitor, run 220-240/1/50	5910.103.18	5910.103.18	5910.103.18	5910.103.49	5910.103.50
Capacitor, run 208-230/1/60	5910.103.18	5910.103.18	5910.103.18	5910.103.49	5910.103.49
Overload, Compressor 115/1/60	5925.571.12	5925.571.12	5925.571.12	5925.571.15	5925.571.15
Overload, Compressor 208-230/1/60	5925.571.13	5925.571.13	5925.571.13	5925.571.16	5925.571.16
Overload, Compressor 220-240/1/50	5925.571.14	5925.571.14	5925.571.14	5925.571.14	5925.571.14
Switch, fault light w/conn.	03.7419-02	03.7419-02	03.7419-02	03.7419-03	03.7419-03
Condenser Fan					
Fan Motor 115/1/60	6105.226.2	6105.226.2	6105.226.2	6105.226.7	6105.226.7
Fan Motor 220-240/1/50	6105.226.4	6105.226.4	6105.226.4	6105.226.9	6105.226.9
Fan Motor 208-230/1/60	6105.226.4	6105.226.4	6105.226.4	6105.226.9	6105.226.9
Fan Blade 115/1/60	6105.378.2	6105.378.2	6105.378.2	6105.378.4	6105.378.4
Fan Blade 208-240-1-50/60	---	---	---	6105.378.6	6105.378.6
Refrigeration System					
Compressor 115/1/60	4130.106.100	4130.106.100	4130.106.100	4130.106.102	4130.106.102
Compressor 208-230/1/60	4130.106.68	4130.106.68	4130.106.68	4130.106.71	4130.106.71
Compressor 220-240/1/50	4130.106.101	4130.106.101	4130.106.101	4130.106.72	4130.106.72
Condenser	4130.112.13	4130.112.13	4130.112.13	4130.112.15	4130.112.15
Hot gas by-pass valve	4130.690.21	4130.690.21	4130.690.21	4130.690.22	4130.690.22
Filter/Dryer	4130.165.12	4130.165.12	4130.165.12	4130.165.12	4130.165.12
Fan Pressure Switch	03.7483-04	03.7483-04	03.7483-04	03.7483-05	03.7483-05
Cabinet					
*Filter, Ambient Air	4460.233.3	4460.233.3	4460.233.3	4460.233.4	4460.233.4
Grommet (light & switch, front panel)	9320.302.11	9320.302.11	9320.302.11	9320.302.11	9320.302.11
Foot, mounting	9330.230.2	9330.230.2	9330.230.2	9330.230.2	9330.230.2

* Maintenance kits for the above models are available "*" indicates items included in the kits.

Maintenance Kits

For Dryer Models	Kit Number
20, 25, 35	RDMK4B
50	RDMK6B
75	RDMK5B

PARTS LIST

PARTS DESCRIPTION	100	125
Separator		
*Separator/Filter Cartridge	E9-24	E9-24
Filter Sleeve	S9-24	S9-24
*Drain Mechanism	05.4170-08	05.4170-08
Bowl	03.0810-06	03.0810-06
*O-ring Bowl	9320.552.16	9320.552.16
Strainer, inlet	4731.735.3	4731.735.3
*Screen, strainer	4731.735.8	4731.735.8
Electrical		
Switch on/off	6110.706.7	6110.706.7
Light, Fault 230v	6350.451.11	6350.451.11
Cord Set	03.7133-25	03.7133-25
Capacitor, run 230/1/60	3065778	3065778
Capacitor, run 220-240/1/50		
Switch, fault light w/conn.	03.7419-03	03.7419-03
Condenser Fan		
Fan Motor	6105.226.9	6105.226.9
Fan Blade	6105.378.5	6105.378.5
Refrigeration System		
Compressor 230/1/60	4130.106.104	4130.106.104
Compressor 220-240/1/50	4130.106.105	4130.106.105
Condenser	4130.112.19	4130.112.19
Hot gas by-pass valve	4130.690.22	4130.690.22
Filter/Dryer	4130.165.12	4130.165.12
Fan Pressure Switch	03.7483-05	03.7483-05
Cabinet		
*Filter, Ambient Air	4460.233.6	4460.233.6
Grommet (light & switch, front panel)	9320.302.11	9320.302.11
Foot, mounting	9330.230.2	9330.230.2

* Maintenance kits for the above models are available "*" indicates items included in the kits.

Maintenance Kits

For Dryer Models	Kit Number
100	RDMK3B
125	RDMK3B

NOTES

WARRANTY

The manufacturer warrants the product manufactured by it, when properly installed, operated, applied, and maintained in accordance with procedures and recommendations outlined in manufacturer's instruction manuals, to be free from defects in material or workmanship for a period as specified below, provided such defect is discovered and brought to the manufacturer's attention within the aforesaid warranty period.

The manufacturer will repair or replace any product or part determined to be defective by the manufacturer within the warranty period, provided such defect occurred in normal service and not as a result of misuse, abuse, neglect or accident. Normal maintenance items requiring routine replacement are not warranted. The warranty covers parts and labor for the warranty period unless otherwise specified. Repair or replacement shall be made at the factory or the installation site, at the sole option of the manufacturer. Any service performed on the product by anyone other than the manufacturer must first be authorized by the manufacturer.

Unauthorized service voids the warranty and any resulting charge or subsequent claim will not be paid. Products repaired or replaced under warranty shall be warranted for the unexpired portion of the warranty applying to the original product.

The foregoing is the exclusive remedy of any buyer of the manufacturer's product. The maximum damages liability of the manufacturer is the original purchase price of the product or part.

THE FOREGOING WARRANTY IS EXCLUSIVE AND IN LIEU OF ALL OTHER WARRANTIES, WHETHER WRITTEN, ORAL, OR STATUTORY, AND IS EXPRESSLY IN LIEU OF THE IMPLIED WARRANTY OF MERCHANTABILITY AND THE IMPLIED WARRANTY OF FITNESS FOR A PARTICULAR PURPOSE. THE MANUFACTURER SHALL NOT BE LIABLE FOR LOSS OR DAMAGE BY REASON OF STRICT LIABILITY IN TORT OR ITS NEGLIGENCE IN WHATEVER MANNER INCLUDING DESIGN, MANUFACTURE OR INSPECTION OF THE EQUIPMENT OR ITS FAILURE TO DISCOVER, REPORT, REPAIR, OR MODIFY LATENT DEFECTS INHERENT THEREIN.

THE MANUFACTURER, HIS REPRESENTATIVE OR DISTRIBUTOR SHALL NOT BE LIABLE FOR LOSS OF USE OF THE PRODUCT OR OTHER INCIDENTAL OR CONSEQUENTIAL COSTS, EXPENSES, OR DAMAGES INCURRED BY THE BUYER, WHETHER ARISING FROM BREACH OF WARRANTY, NEGLIGENCE OR STRICT LIABILITY IN TORT.

The manufacturer does not warrant any product, part, material, component, or accessory manufactured by others and sold or supplied in connection with the sale of manufacturer's products.

Warranty Period

Parts and labor for two (2) years from the date of shipment from the factory; heat exchangers are covered (parts only) for an additional three (3) years (total of five (5)). On units that manufacturer requests be returned to the factory, a one time removal/reinstallation labor allowance as noted in the Service Warranty Policies and Procedures Handbook will apply. Freight to the factory from the installation site and to the installation site from the factory will be paid by the manufacturer; means of transportation to be specified by manufacturer.

AUTHORIZATION FROM THE SERVICE DEPARTMENT IS NECESSARY BEFORE MATERIAL IS RETURNED TO THE FACTORY OR IN-WARRANTY REPAIRS ARE MADE.

SERVICE DEPARTMENT: (724) 746-1100

SPX DELTECH

SPX Dehydration & Process Filtration
1000 Philadelphia Street
Canonsburg, PA 15317-1700 U.S.A.
Phone: 724-745-8647 • Fax: 724-745-4967
Email: deltech.inquiry@dehydration.spx.com
www.deltech-spx.com

SPX Dehydration & Process Filtration Canada
1415 California Avenue
Brockville, ON, Canada, K6V 7H7
Phone: 613-345-2280 • Fax: 613-345-7240
Email: salescanada@dehydration.spx.com
www.deltech-spx.com