

POWEREX[®]

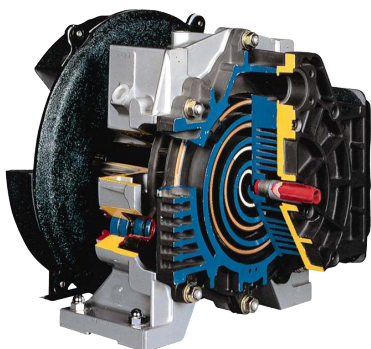

Enclosed Tankmount Systems

OIL-LESS SCROLL TECHNOLOGY



As the scroll orbits, a crescent-shaped cavity is gradually reduced, compressing the air and exhausting it through the final discharge point at the center. During operation, all the gas passages are in various stages of compression at all times, resulting in nearly continuous compression and discharge.

Our innovative scroll technology is completely oil-less, extremely quiet, energy efficient and easy to maintain. Sound enclosures decrease noise levels even further, allowing the compressor system to be installed right at the point of use, while the small footprint also helps maximize available floor space.

The scroll pump has few moving parts making it reliable and easier to maintain. The self lubricating tip seals and absence of a gearbox means the pump is truly 100% oil free.

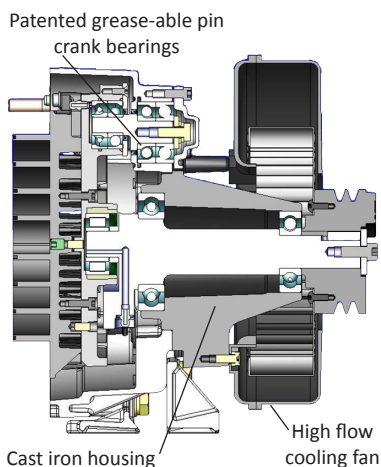

- Main bearings are housed in durable cast iron instead of aluminum which prevents fretting and premature failure of the bearing race. This pump can be operated at 100% duty with confidence.
- The patented bearing re-grease feature has been improved to allow maintenance from the front side of the pump, cutting service time in half.
- The patented tip seal design yields the highest flow rates and longevity of any other dry scroll compressor.
- The improved efficiency and cooling results in lower operating temperatures.
- Extremely low vibration.
- Industry first 10hp scroll pump improves system efficiency by producing more output using fewer pumps.

WhisperAIR™ SOUND ENCLOSURE CABINET

Powerex's trademarked oil-free enclosure systems offer the lowest noise levels in the industry. Each system is packaged in a rigid steel frame with powder coated panels and lined with sound-deadening insulation. The low noise levels are unmatched in the industry and allow installation at the point of use, while the small footprint simultaneously maximizes floor space.

WhisperAIR™
PATENT PENDING
**OIL-LESS
SCROLL**



SYSTEMS SPECIFICATIONS

Model	SCFM @ 100 PSIG	System HP	Pump HP	Phase	dB(A)	Tank (gal.)
SIMPLEX						
STES0754	23.1	7.5	7.5	3	60	120
STES10B4	31.2	10	10	3	61	120
DUPLEX						
STED0755	46.2	15	7.5 (2)	3	62	200
STED10B5	62.4	20	10 (2)	3	63	200

APPLICATIONS

- Laboratory
- Food/Beverage Processing & Packaging
- Sterilizers
- Gas Generation
- Environmental
- Pharmaceutical & Nutraceutical
- Textile
- Semiconductor
- Medical Device

STANDARD FEATURES

- UL508A Control Panel
- User-friendly touchscreen HMI controls with integrated PLC
- Adjustable set points
- Remote inlet standard
- Patent-pending cooling system within WhisperAIR™ Sound Enclosure Cabinet
- Maintenance-friendly
 - Easy to remove latched panels
 - Standard service slide to easily access pump
- Minimal footprint – Simplex system can fit through a 36" door
- 16°F approach temperature
- Electric automatic tank drain

OPTIONS

- BACnet Gateway
- Simplex – installed refrigerated or desiccant dryer
- Simplex – installed dewpoint monitor and/or CO monitor
- Duplex – separate power feed with pump isolation
 - Built in redundancy
 - Electrical and mechanically isolate one pump while other pump is running
 - Perform OSHA-approved maintenance on isolated pump
- Corrosion resistant, FDA-approved phenolic lining
- 50 Hz motor



Simplex configuration with installed desiccant dryer

For more information contact your local Powerex distributor or Powerex sales representative today



The leader in oil-free air technology



150 Production Drive • Harrison, OH 45030 • USA
T 1.888.769.7979 • F 513-367-3125 • www.powerexinc.com



Powerex is a proud manufacturer of ISO8573-1 "Class Zero" Oil-free compressed air systems using oil-less scroll and oil-free rotary tooth technology. Powerex is located just outside of Cincinnati, OH, and is a leading manufacturer of oil-less compressed air and vacuum systems for medical gas, laboratory, and critical-process industrial applications. We are an ISO 9001 manufacturing facility that is able to provide complete air systems including tanks, UL508A control panels, and dryers. Contact Powerex today to match you with the right compressor for your application.