

REVISION HISTORY		DATE	DWN	CHK
ZONE	REV	DESCRIPTION		
	A	RELEASED PER ECN 1089696	2/12/2015	MRF KWT

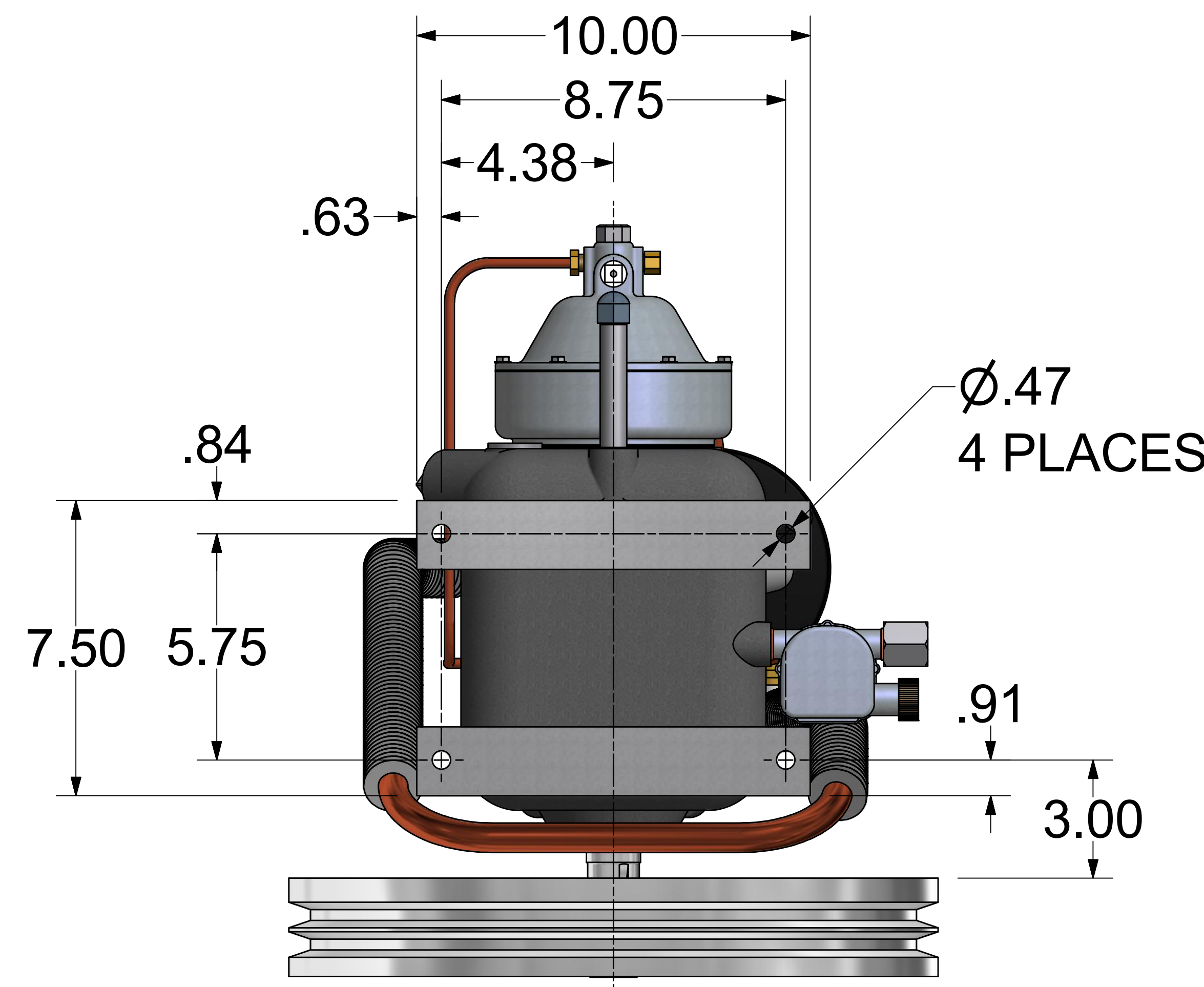
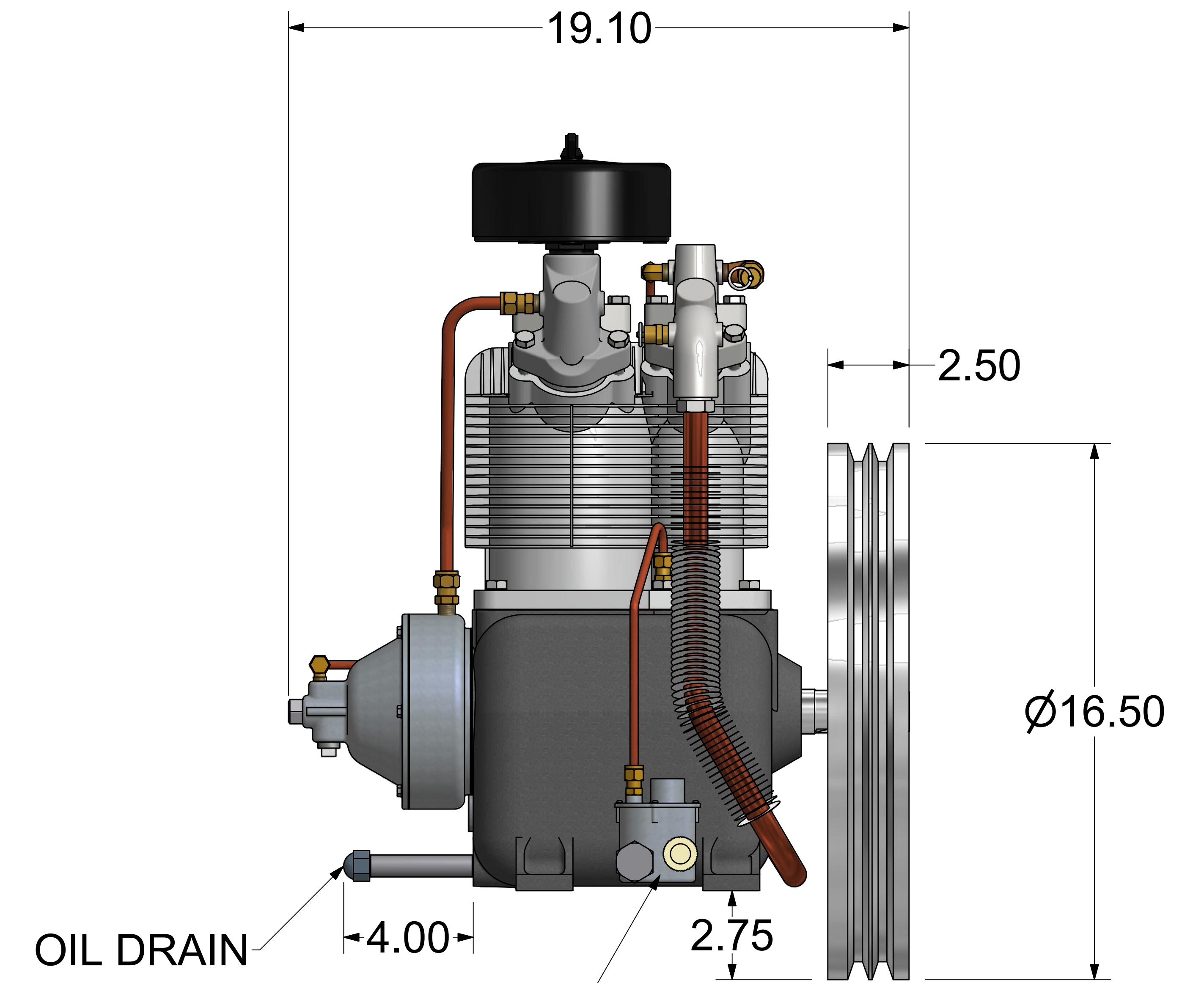
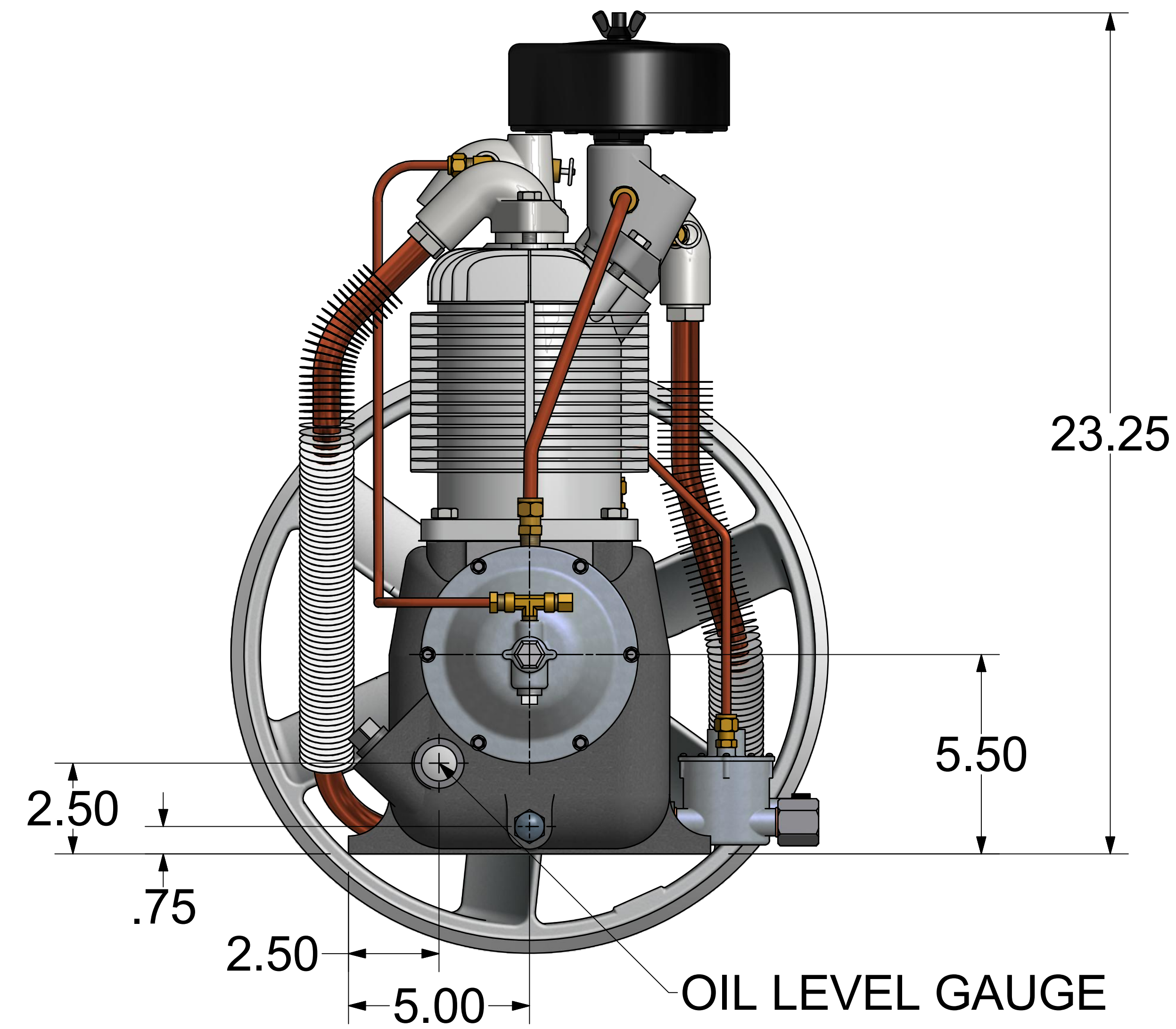
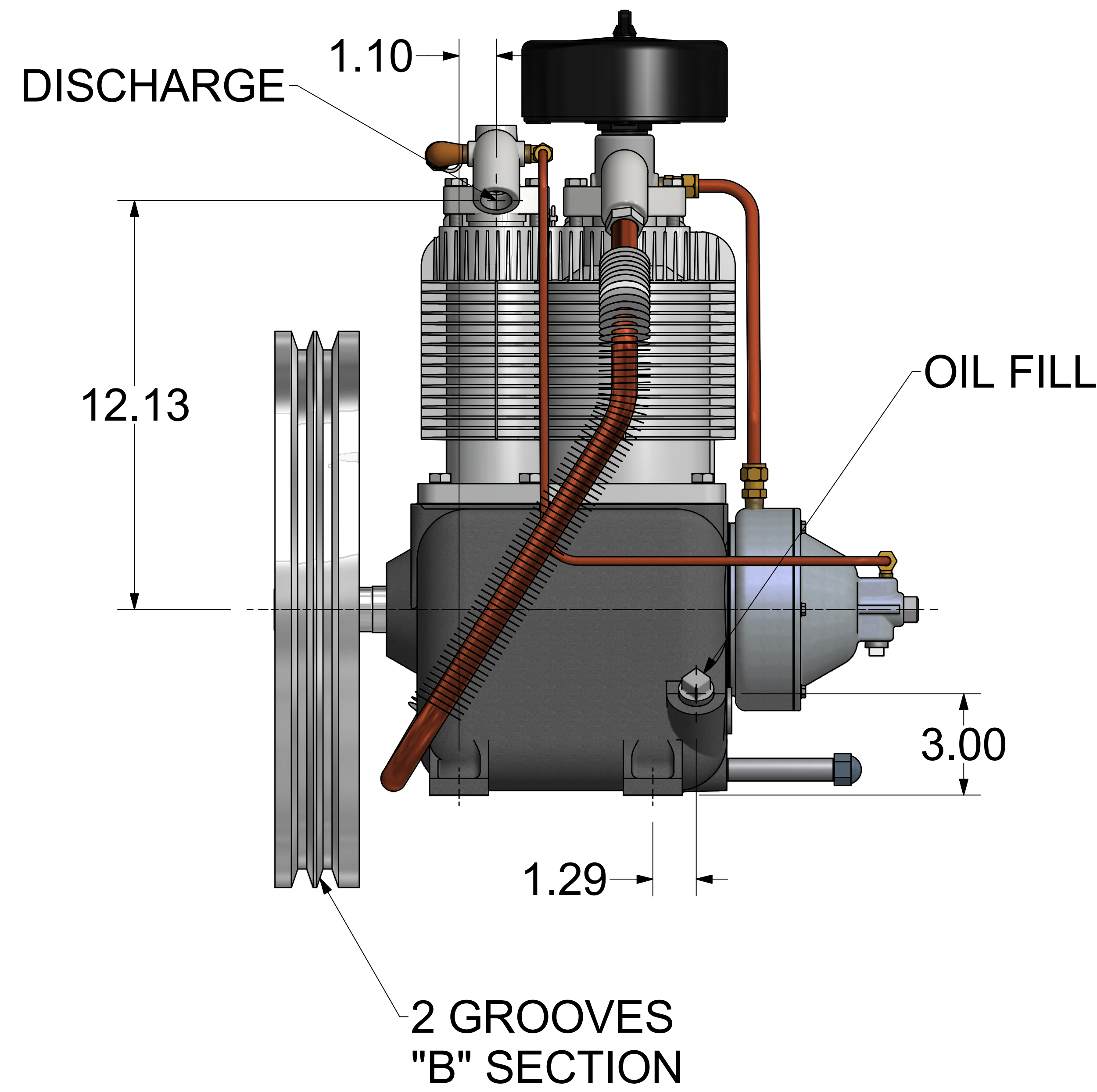
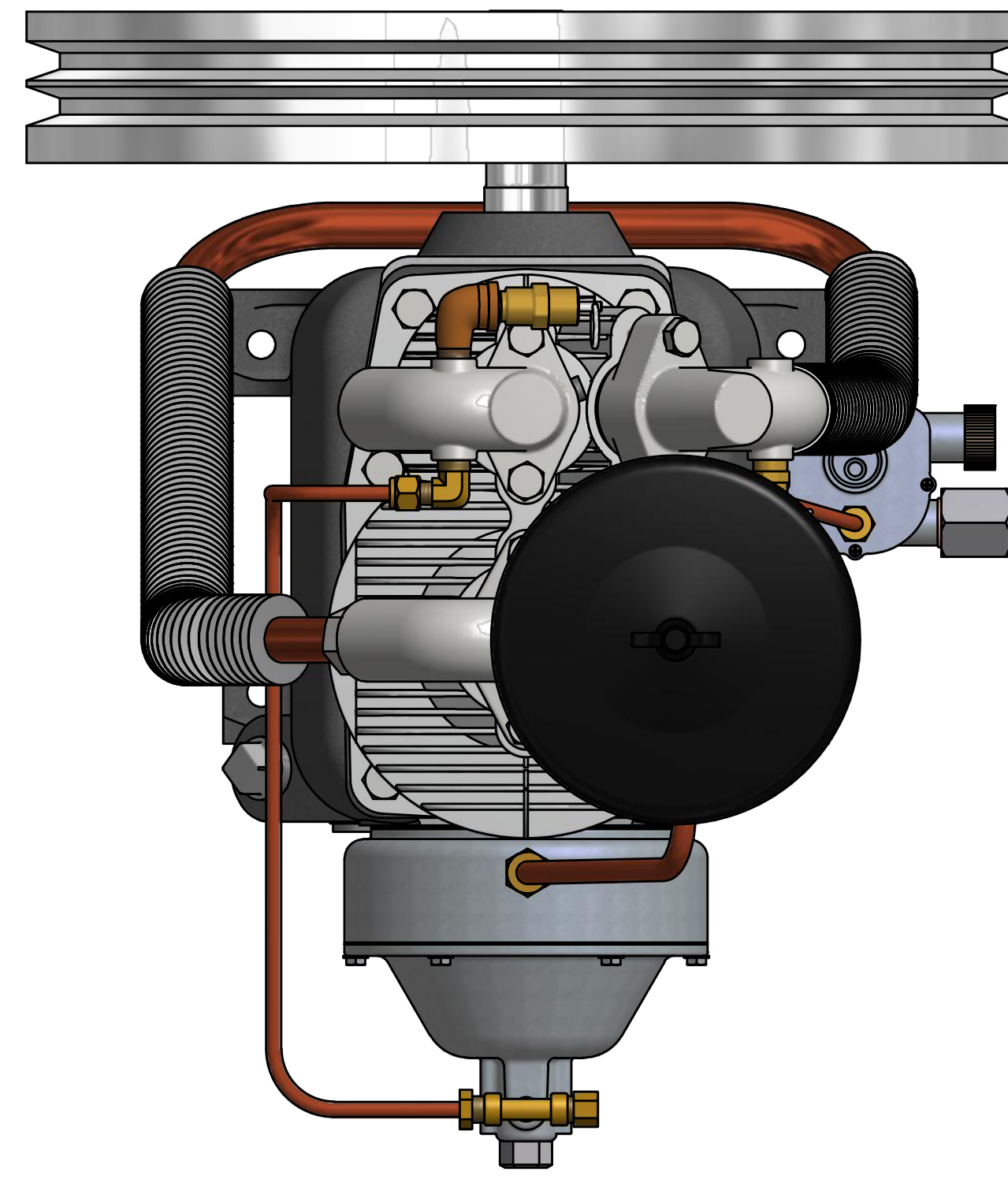
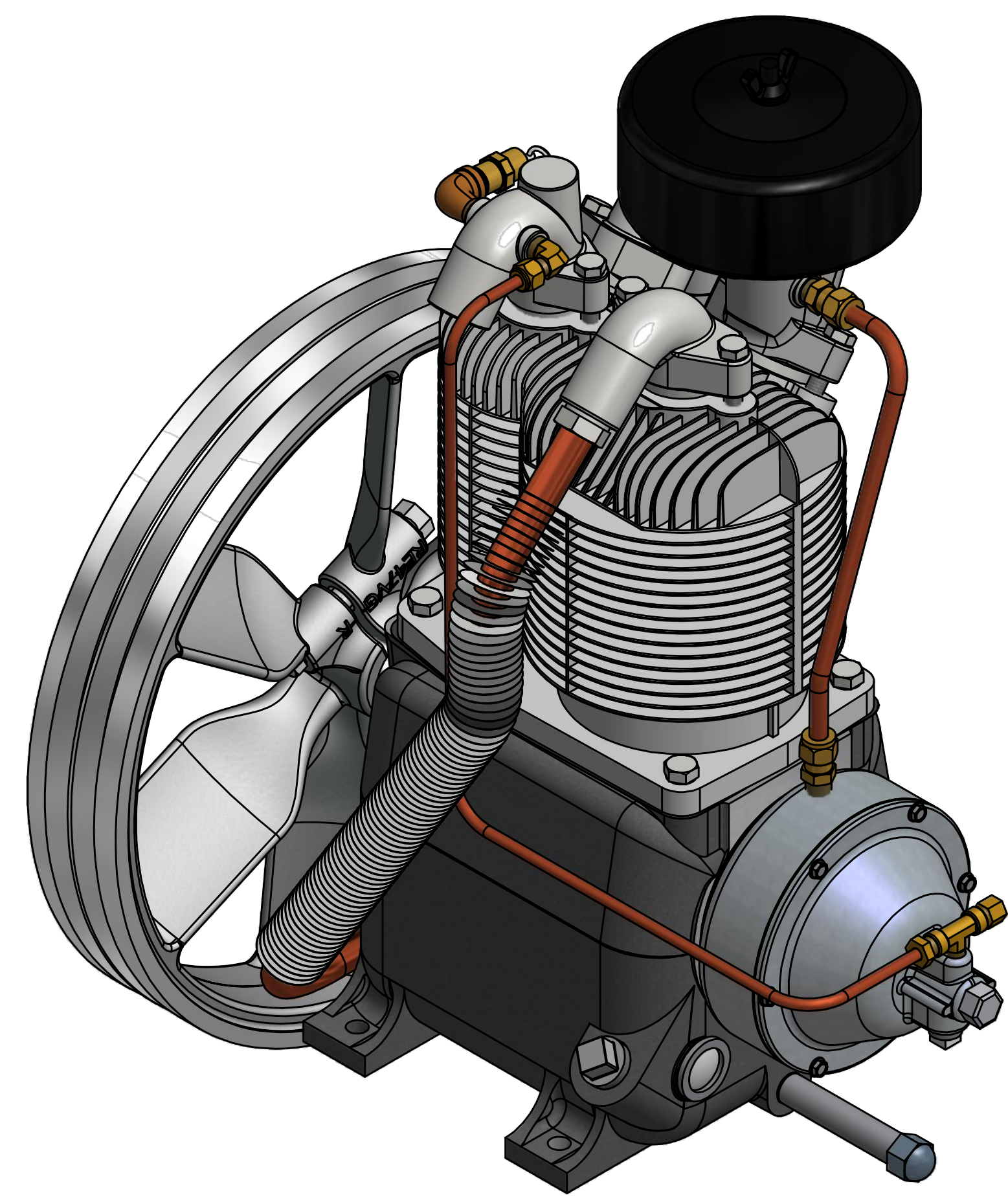

NOTES:

1. DO NOT SCALE DRAWING.
2. SPECIFICATIONS AND DIMENSIONS ARE SUBJECT TO CHANGE WITHOUT NOTICE OR OBLIGATION.
3. ALL DIMENSIONS IN INCHES.

FINISH OF CHAMFERS AND FILLETS TO CONFORM TO ROUGHEST ADJACENT AREA. SURFACE ROUGHNESS MAXIMUM PER ASME B46.1. FULL THREAD DEPTHS ARE MINIMUM.		CONFIDENTIAL - THE INFORMATION CONTAINED IN THIS DOCUMENT IS THE PROPERTY OF GARDNER DENVER, INC. IT IS NOT FOR PUBLIC DISCLOSURE. POSSESSION OF THE INFORMATION DOES NOT CONVEY ANY RIGHT TO LOAN, SELL OR DISCLOSE THE INFORMATION UNAUTHORIZED REPRODUCTION OR USE OF THE INFORMATION IS PROHIBITED. THIS DOCUMENT IS TO BE RETURNED TO GARDNER DENVER, INC. UPON THE COMPLETION OF THE PURPOSE FOR WHICH IT IS LOANED OR UPON REQUEST.	
UNLESS OTHERWISE SPECIFIED DIMENSIONS ARE IN INCHES		DIMENSIONING AND TOLERANCING PER ASME Y14.5-2009	
TOL. ON DECIMALS: .X = ± .05		THREADS PER ASME B1.1 GAGING SYSTEM 21 U.O.S., ANSI B1.20.1 & B1.20.3	
TOL. ON DECIMALS: .XX = ± .02		HEAT TREATMENT	
TOL. ON DECIMALS: .XXX = ± AS SPECIFIED		ENG. REF:	
TOL. ON ANGLES: ± 0°-30'		Gardner Denver Inc. Quincy, IL	
THIRD ANGLE PROJECTION		TITLE: OUTLINE - BARE UNIT	
DWN BY MRF 2/12/2015		R10D & R15B	
CKD BY KWT 2/12/2015		305CAP800	
SCALE		SHEET 1 OF 1	